

THE RADIO EXPERIMENTER'S MAGAZINE

HUGO GERNSBACK
Editor

SHORT WAVE CRAFT

December

Combined
With

OFFICIAL
**Short Wave
Listener**
MAGAZINE

WORLD'S
LARGEST
SHORT WAVE
CIRCULAR

World's Smallest
Short Wave Receiver
See Page 466



25¢

IN U. S. AND
CANADA

SAVE UP TO 50% at Factory Prices!

You'll Be Excited over **MIDWEST'S**
DIAL-A-MATIC Tuning and Exclusive **ELECTRIK SAVER!**

Your radio enjoyment is doubled with Dial-A-Matic Tuning, the amazing new Midwest feature that makes this radio practically tune itself. Now, even a child can bring in ten perfectly tuned programs in ten seconds! It's a big thrill to whirl the dial . . . and then hear the station you want . . . come in instantly, automatically, perfectly. Zip-zip-zip . . . the programs roll in perfectly tuned . . . as fast as you can press buttons! This new Midwest feature will perform new miracles of radio for you.

New 1937
AIR-TESTED
5-BAND

16-Tube **MIDWEST**
Radio

9 to 2200
METERS

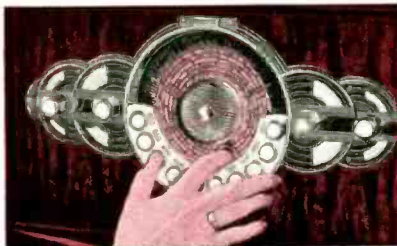

30 Days FREE Trial!

Send for big FREE 40-page 1937 Midwest catalog—before you buy any radio—and see for yourself why scores of thousands of radio purchasers have saved up to 50% by ordering the Midwest factory - to - you way since 1920. Learn why Midwest radios are preferred by famous movie stars, orchestra leaders, musicians, sound technicians, and discriminating radio purchasers everywhere.

Once again, Midwest demonstrates its leadership by offering this amazingly beautiful, bigger, better, more powerful, 16-tube, 5-band world-wide radio—a startling achievement that makes the whole world your radio playground. Out-performs \$150 radios on point-for-point comparison. Powerful Triple-Twin Tubes (two tubes in one) give 20-tube results.

over its marvelous super-performance . . . glorious crystal-clear "concert realism" . . . and magnificent world-wide foreign reception. Scores of marvelous Midwest features, many of them exclusive, make it easy to parade the nations of the world before you. You can switch instantly from American programs . . . to Canadian, police, amateur, commercial, airplane and ship broadcasts . . . to the finest, most fascinating world-wide foreign programs.

Only **\$49.95** COMPLETE WITH GIANT THEATRE-SONIC SPEAKER (LESS TUBES)

TERMS AS LOW AS **\$5.00** DOWN

Only **MIDWEST** Gives You

16 TUBES • 5 WAVE BANDS

9 to 2200 METERS • ELECTRIK SAVER

- **DIAL-A-MATIC TUNING** •
- **AUTOMATIC AERIAL ADAPTION** •
- DUAL AUDIO PROGRAM EXPANDER**

BECOME YOUR OWN RADIO DEALER

Save the jobber's-retailer's profits that often amount to 50% of ordinary retail prices. Become your own radio dealer and buy at wholesale prices direct from the Midwest factory. Never before so much radio for so little money! Why pay more?



This super deluxe Midwest radio is so amazingly selective, so delicately sensitive, that it brings in distant foreign stations with full loud speaker volume on channels adjacent to powerful locals. You'll thrill

ELECTRIK-SAVER

This exclusive Midwest feature cuts radio wattage consumption 50% . . . results in Midwest radios using no more current than ordinary 7-tube sets . . . enables them to operate on voltages as low as 80 volts.

Before you buy any radio, send for our big FREE 40-page 1937 catalog—and take advantage of Midwest's sensational factory-to-you values. You have a year to pay and terms are as low as 10c per day—and you secure the privilege of 30 days' FREE trial in your own home. In addition you are triply protected with Foreign Reception Guarantee, Full-Year Warranty and Money-Back Guarantee.



MY MIDWEST NOT ONLY MEETS BUT SURPASSES MY MOST CRITICAL STANDARDS.
Bing Crosby



NO SET THAT I HAVE EVER OWNED HAS BROUGHT IN FOREIGN RECEPTION SO CONSISTENTLY AND SATISFACTORILY.
Gloria Stuart



MIDWEST RADIO CORP.

DEPT. F-14
Established 1920



CINCINNATI, OHIO, U.S.A.

Cable Address MIRACO...All Codes

MAIL COUPON TODAY for
Free 30-DAY TRIAL OFFER
and 40-PAGE FOUR-COLOR Free CATALOG

MIDWEST RADIO CORPORATION

Dept. F-14, Cincinnati, Ohio

Without obligation on my part, send me your new FREE catalog and complete details of your liberal 30-day FREE trial offer. This is NOT an order.

Special offer and prices prevail only when dealt with factory by mail.

Name _____
Address _____
Town _____ State _____

SHOP IN YOUR SLIPPERS



PARK YOUR FEET AFTER 6 p.m.—GET the BLUE RIBBON RADIO CATALOG FREE

SWIFT DELIVERY

THOSE valuable daylight hours were intended for work—NOT to be wasted in shopping around for parts, tubes, instruments. Get the "WHOLESALE" habit—a few minutes spent with the Blue Ribbon Catalog in the evening will take care of your purchasing! And it's CHEAPER, too! It is also easier—for no matter what your requirements, you'll find them in the 1937 BLUE RIBBON RADIO CATALOG. If it's radio—you'll find it here!

ANOTHER WHOLESALE FEATURE

The most complete research department in the country is maintained by WHOLESALE. Each year we assist THOUSANDS of our Ham and experimenter friends in the solution of their problems. Are you stuck on a tough or unknown circuit? Let WHOLESALE give you the "low-down." Are you trying to build a new "rig"? Tell your troubles to WHOLESALE—our "Ham" technicians know the answer. No matter what your problem—if it's RADIO—go to WHOLESALE.

HOO MON! 'TIS SMART TO BE THR-RIFTY! SEND FOR THIS BRAW-BONNY BOOK—'T WILL SAVE YE MONEY



EVERYTHING YOU NEED IN RADIO

Only "Wholesale Radio Service Co., Inc." can promise TWENTY-FOUR HOUR shipments. This is made possible by the modern Teletype Communication system which connects our completely stocked branch warehouses. No matter where you are located, this modern communication system and our large, efficient staff combine to get your order to you SWIFTLY. Why waste time and transportation expense in "going to town"? Buy your radio requirements the EFFICIENT WAY—the SWIFT way—the "WHOLESALE" way. Twenty-four hour shipments are a "Wholesale" rule!

10 THOUSAND BARGAINS

Within the more than 150 pages of the Blue Ribbon Catalog, you will find more radio bargains than you ever heard of. Bargains in all brands of parts—bargains in every type of test equipment you ever heard of—bargains in P.A. equipment—bargains in tubes—bargains in "Ham" equipment. And REMEMBER—no product is listed in our catalog until it has been subjected to, and PASSED the exacting tests prescribed by our laboratory technicians. THAT is your assurance of QUALITY parts—

SEND IN THIS COUPON NOW

WHOLESALE RADIO SERVICE CO., INC.
100 Sixth Avenue, New York, N. Y.

Rush FREE "Blue Ribbon" Catalog No. 65—M4

NAME

Street

City State

WHOLESALE RADIO SERVICE CO. INC.

CHICAGO, ILL.
901 W. JACKSON BLVD.

NEW YORK, N.Y.
100 SIXTH AVENUE

ATLANTA, GA.
430 W. PEACHTREE ST. N.W.

BRONX, N.Y.
542 E. FORDHAM RD.

NEWARK, N.J.
219 CENTRAL AVE.

Please mention SHORT WAVE CRAFT when writing advertisers

IN THIS ISSUE: PROMINENT SHORT-WAVE AUTHORS

Hoover • Shuart • Hooton • Elgin • Palmer • Edwards • Secor



HUGO GERNSBACK
Editor

H. WINFIELD SECOR
Managing Editor

GEORGE W. SHUART,
W2AMN
Associate Editor

Combined With
Official SHORT WAVE LISTENER

Contents for December, 1936

Editorial—"Short Wave Radio Paging," by Hugo Gernsback	461
Even The Tugboats Go Short-Wave!.....	462
Short Waves Kept "Lady Peace" In Touch With Land Short Waves, Plus Strings, Guide Planes.....	463
What I Saw at the New York Radio Show, by "Spectator".....	464
NBC's Chief Engineer O. B. Hanson Discusses Television and Short Waves—An Interview, by H. W. Secor	465
Hoover "Tinymite"—The Smallest S-W Receiver (Cover Feature), by L. S. Hoover.....	466
Short Wave Scouts—Thirty-Third Silver Trophy Award	467
A "Real" 5-Meter Super-Het, by George W. Shuart, W2AMN	468
The "2-Volt" Super DX-4, by Harry D. Hooton, W8KPX	470
"Universal" Receiver Works on A.C.-D.C. or Battery, by Anthony C. Elgin	472
\$5.00 For Best Short-Wave Kink.....	473
A 1937 Desk Type Transmitter, by George W. Shuart, W2AMN	474
World-Wide Short-Wave Review—Edited by C. W. Palmer	476
Short Waves and Long Raves—Our Readers Forum.....	478
Fixed Condensers Made from Coils of Wire.....	480
Grid Bias—How and Why, by Norman C. Edwards.....	480
What's New in Short-Wave Apparatus.....	481
25 Watt Junior Transmitter, by Frank Lester, W2AMJ	481
New Apparatus for the "Ham".....	482
The BS-5 Five-Band "Bandswitch" Receiver, by Guy Stokely, E.E.	482
The Radio Amateur, Conducted by Geo. W. Shuart.....	483
Let's "Listen In" With Joe Miller—Our Short-Wave "DX" Editor.....	484
World S-W Station List, by Harvey Gernsback.....	485
Alphabetical List of S-W Stations.....	489
Short Wave Question Box.....	490
Short Wave League and Scout News.....	492



Certified Circuits

● **SHORT WAVE CRAFT** goes to a large expense in verifying new circuits. When you see this seal it is your guarantee that such sets have been tested in our laboratories, as well as privately, in different parts of the country. Only "Constructional-Experimental" circuits are certified by us.

When you see our certified seal on any set described, you need not hesitate to spend money for parts, because you are assured in advance that the set and circuit are bona fide and that this magazine stands behind them.

SHORT WAVE CRAFT is the only magazine that certifies circuits and sets.

OUR COVER

● THE cover illustration this month shows the smallest 1-tube radio set which employs a single 955 "Acorn" tube. The set is operated by small batteries with 7 feet of No. 36 copper wire as the antenna, no ground being necessary. The Hoover "Tinymite" is described and illustrated on Page 466.

COPYRIGHT, 1936. BY H. GERNSBACK

Published by **POPULAR BOOK CORPORATION**

404 N. Wesley Avenue. Mount Morris, Ill.
Editorial and Executive Offices - - - 99-100 Hudson St., New York, N. Y.
HUGO GERNSBACK, President - - - **H. W. SECOR, Vice-President**
EMIL GROSSMAN - - - **Director of Advertising**
Chicago Adv. Office - - - **L. F. McCLURE, 919 No. Michigan Ave.**
European Agent: Goringe's American News Agency, 9A Green St., Leicester Square, London W. C. 2
Australian Agents: **McGILL'S AGENCY, 179 Elizabeth St., Melbourne**

Features in the Jan. "Ham" Issue

- Choosing the Right Transmitting Tube! by Robert S. Kruse.
- Television Advances in Europe.
- Improving the 5-Meter Superhet., by George W. Shuart, W2AMN.
- Part 2 of the 1937 Desk-Type Transmitter, 5 to 80 Meters, by W2AMN.
- A Crystal-Controlled 5 and 10-Meter Transmitter, by Maurice E. Kennedy, W6KQ-W6BGC.
- How to Build and Calibrate a Combined "Beat" and "Test" Oscillator, by Harry D. Hooton, W8KPX.
- Plenty of Receiver and other articles for the S-W "Fan."

SHORT WAVE CRAFT—Monthly. Entered as second class matter May 7, 1930, at the post office at Mount Morris, Illinois, under the act of March 3, 1879. Trademarks and copyrights by permission of H. Gernsback, 99-101 Hudson St., N. Y. C. Text and illustrations of this magazine are copyrighted and must not be reproduced without permission. **SHORT WAVE CRAFT** is published on the 1st of every month. Twelve numbers per year. Subscription price is \$2.50 a year in the United States and Possessions and Canada. Foreign countries, \$3.00 a year. Single copies 25c. Address all contributions for publication to Editor, **SHORT WAVE CRAFT, 99-101 Hudson St., New York, N. Y.** Publishers are not responsible for lost manuscripts. Contributions cannot be returned unless authors remit full postage. **SHORT WAVE CRAFT** is for sale at all principal newsstands in the United States and Canada. European agents: Brentano's, London and Paris. Printed in U. S. A. Make all subscription checks payable to Popular Book Corporation.

OPPORTUNITIES *are many* for the Radio Trained Man

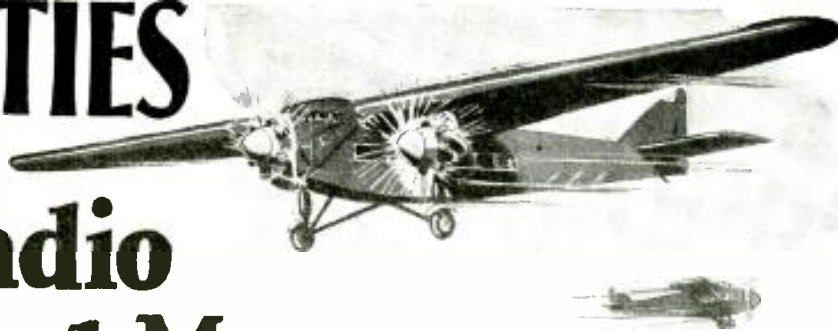

Don't be an untrained man. Let me show you how to get your start in Radio—a fast growing, live money-making industry.

Prepare for jobs as Assembler, Inspector and Tester—Radio Sales or Service and Installation Work—Broadcasting Station Operator—Wireless Operator on a Ship or Airplane, Talking Picture or Sound Work—**HUNDREDS OF OPPORTUNITIES** for a real future in Radio!

12 Weeks of Shop Training Pay Your Tuition After Graduation



We don't teach by book study. We train you on a great outlay of Radio, Television and Sound equipment—on scores of modern Radio Receivers, actual Broadcasting equipment, Television apparatus, Talking Picture and Sound Reproduction equipment, Code and Telegraph equipment, etc. You don't need advanced education or previous experience. We give you—**RIGHT HERE IN THE COYNE SHOPS**—the actual practice and experience you'll need for your start in this great field. And because we cut out all useless theory and only give that which is necessary you get a practical training in 12 weeks. Mail coupon for all facts about my school and training methods.

TELEVISION *and* TALKING PICTURES

Television is sure to come as a commercial industry. Whether this year or later, it will offer opportunities to the man who is trained in Radio. Here at Coyne you learn Television principles, and work on actual Television equipment. Talking Picture and Public Address Systems offer opportunities to the Trained Radio Man. Here is a great new Radio field which is rapidly expanding. Prepare **NOW** for these wonderful opportunities! Learn Radio Sound Work at **COYNE** on actual Talking Picture and Sound Reproduction equipment.

ARRANGE TO FINANCE YOUR TUITION

Mail the Coupon below and I'll tell you about my finance plan which has enabled hundreds of others to get Coyne training with very little money. On this plan you can get your training first, then take 18 months to complete your small monthly tuition payments starting 5 months after you begin training. Not a home study course.

Mail the coupon for all details of this "Pay Tuition after Graduation Plan."

ELECTRIC REFRIGERATION—AIR CONDITIONING—DIESEL ENGINES

To make your training more valuable, I include—at no extra cost additional instruction in Electric Refrigeration, Air Conditioning and Diesel Engines, taught you by personal instruction and actual work on real equipment.

PRACTICAL WORK At COYNE in Chicago

ACTUAL, PRACTICAL WORK. You build and service radio sets. You get training on real Broadcasting equipment. You construct Television Receiving Sets and actually transmit your own Television images over our Television equipment. You work on real

H. C. LEWIS, Pres. RADIO DIVISION Founded 1899

Coyne Electrical School
500 S. Paulina St., Dept. 96-2K, Chicago, Ill.

Talking Picture and Sound equipment. You learn Wireless Operating on Actual Code Practice apparatus. We don't waste time on useless theory. We give you the practical training you'll need for your start in Radio—in 12 short weeks. If you desire code, this requires additional time for which there is no extra charge.

MANY EARN WHILE LEARNING



If you need part-time work to help pay living expenses while at school, tell us your problems and we may be able to help you as we have hundreds of other students. Then, after you graduate, our Free Employment Department will give you life-time employment service. Every Coyne graduate also receives a Life Scholarship, with free technical and business service and privilege of review at any time without additional tuition charge.

Mail Coupon Today for All the Facts

H. C. LEWIS, President
Radio Division, Coyne Electrical School
500 S. Paulina St., Dept. 96-2K, Chicago, Ill.

Dear Mr. Lewis:—Send me your Big Free Radio Book, and all details of your tuition offer, including additional instruction in Electric Refrigeration, Air Conditioning and Diesel Training and your "Pay After Graduation" offer.

Name.....
Address.....
City..... State.....

Now!
THE NEW 1937
SUPREME
INSTRUMENTS
Are Ready for You

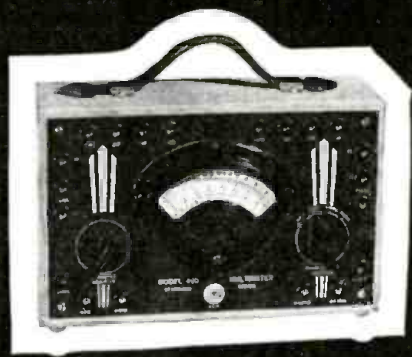

No. 490 MULTI-TESTER

Here is a really good instrument at a price that assures one hundred cents on the dollar value. Each Range is carefully calibrated and accuracy is assured. Incorporates the famous Supreme 5" Fan Shaped Meter with a sensitive 500 microampere movement. 28 ranges. Verichromed bakelite panel, Golden Oak Carrying Case. Cash Price \$22.95 S. I. C. Easy Payment Price \$4.00 Deposit; five monthly payments of \$4.25

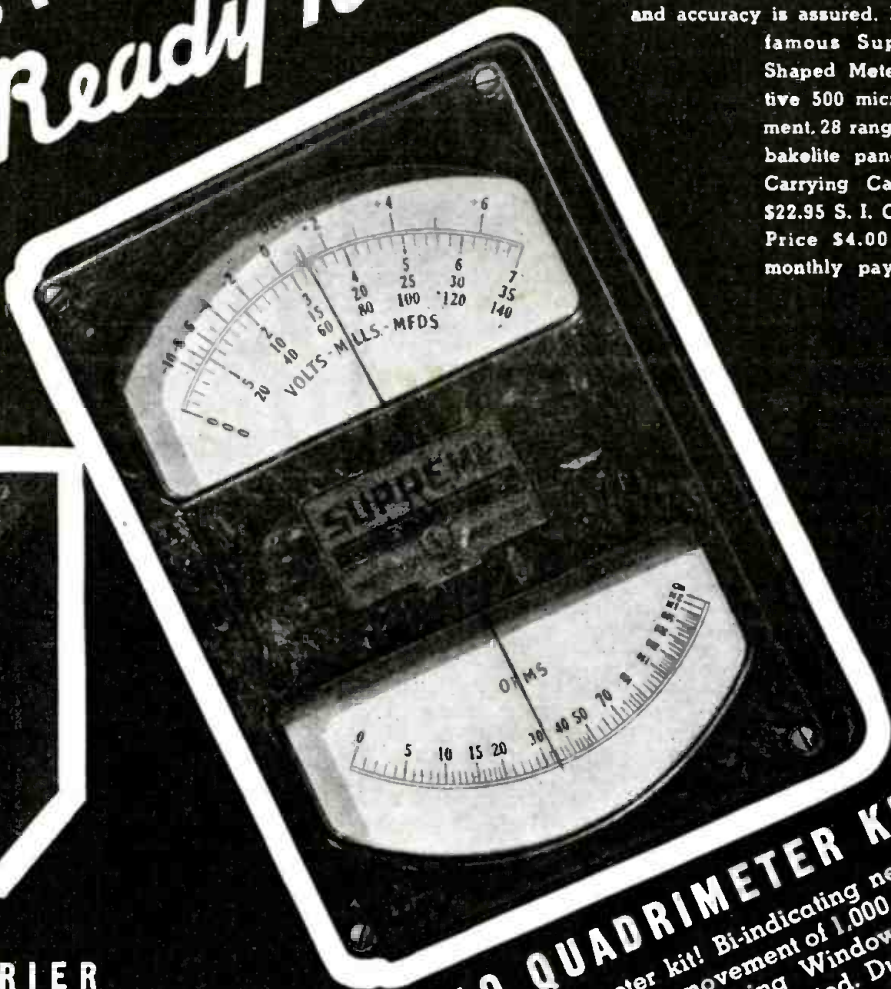

No. 510 QUADRIMETER KIT

Here is a complete meter kit! Bi-indicating needle, driven by a hi-torque 1-mil. movement of 1,000 ohms-per-volt sensitivity. Dual Viewing Windows with scales 4" long. — indirectly illuminated. Dust proof easily removable bakelite cover. 27 ranges are available. Kit includes one SUPREME Bi-Indicating Quadrimeter, one meter adjustment resistor, 15 resistors with 6 attached matching capacitors, one 0-3600 ohm potentiometer, one A.C. rectifier and all necessary switches. Price only \$17.95.

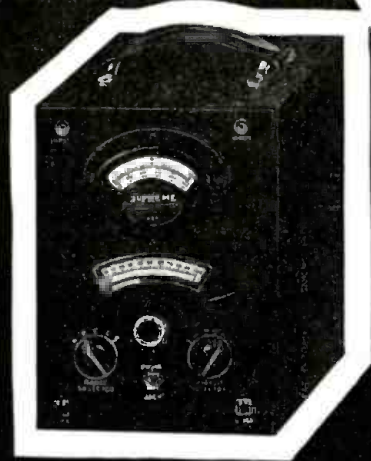

No. 565 CARRIER SHIFT INDICATOR

Now, for the first time, this instrument is available to all amateurs and experimenters! It has been built in answer to a wide demand is reasonable in price, but sufficiently versatile in function and accurate in results to fit the most delicate requirements. Covers the 5 most popular amateur bands. Write for complete details and special prices regarding this remarkable instrument today!

SUPREME INSTRUMENTS CORP. GREENWOOD MISS., U. S. A.
 EXPORT DEPT., ASSOCIATED EXPORTERS CO., 145 W. 45th STREET, NEW YORK, N. Y., CABLE ADDRESS: LOPREH, N. Y.

Please mention SHORT WAVE CRAFT when writing advertisers



December, 1936 Issue—Vol. VII, No. 8.

Short Wave Radio Paging

An Editorial by Hugo Gernsback

● ALMOST every week, new uses for short waves are introduced and, as happens frequently, many obvious and important services have to wait their turn.

One of the most striking of these services is *police radio*, which has demonstrated its worth during the past few years so thoroughly, that today no fair-sized municipality would wish to get along without it. Short waves enable police cars to work with lightning-like speed today, and, often, during a burglary or holdup the burglar is surprised in the act by the police, tipped off by some onlooker who quickly telephoned the information to headquarters.

Another equally important—perhaps, more important—use of short-wave radio will soon become commonplace all over the land. It is one thing to have a police car surprise a burglar trying to get away with a few hundred dollars, and quite another story when you yourself lie propped up in bed while your life is ebbing away in a relapse. Yet your doctor cannot be reached, because he is out on a call and may not be heard from for hours.

To be sure, in big cities like New York and Chicago there is now in use the so-called "Doctors' Telephone Service," whereby a doctor can be located quickly, *providing he is within reach of a telephone*. Suppose, however, that the doctor is *en route* somewhere, making a number of calls, and the patients have no telephone—what then? Or suppose the doctor who, after all, is a human being like the rest of us, is taking an outing in the nearby country or, on a Sunday, is away on a picnic in the woods—what then? It is well known that many patients who need quick attention often die because their own physician could not get to them in time. Getting another doctor—if he can be had at all—does not solve the problem. In many diseases, it is quite possible that the doctor who is familiar with the patient is the only one capable of giving immediate medical help to the patient. There are many cases where only a doctor who knows the existing condition of the patient is really competent to treat it. Thus, for instance, an obstetrical patient should obviously have her own physician. If this patient should, let us say, suddenly develop convulsions, the physician knowing the background is naturally best able to give the patient intelligent and proper care.

After certain operations which develop a hemorrhage, the doctor who performed the operation is the only one qualified to treat the patient. He alone can give the proper attention. Many patients react in an extraordinary manner to certain drugs. Thus an ordinary drug, administered in the usual dose by a physician not familiar with the patient's history, often results in serious illness and even death.

An item in the *New York Times*, dated November 11, 1935, illustrates this graphically. It describes how a patient's life was saved when a radio police car was able to trace and overtake a particular doctor while he was traveling in his automobile in New York.

Take another case—and multiply it by about a million a year—and you will then have an adequate idea why speed in summoning your physician is necessary.

There are over a million automobile accidents in this

country in a year. Let us pick from these an ordinary example. You are traveling in the suburbs in your car when some drunken driver crashes into you. In a few minutes you are removed, unconscious, to the nearest hospital. Now, not all hospitals are well-equipped, nor have they the best doctors or surgeons at all times. Suppose the accident occurs at two o'clock in the morning. It is quite certain that the head surgeons will not be in the hospital. You are, therefore, turned over to the internes who are just learning the profession and do as much for you as they can—which isn't, as a rule, very much. In other words, they are still in the experimental stage and you become merely another one of the *experiments*, where—with one or more nurses' help—they do as well by you as their limited knowledge allows. If you regain consciousness and become aware of what is going on, you haven't got much chance of doing anything about it, nowadays. And, if you should insist that your own doctor be called immediately, the chances are that he might not be reached. He may himself be out on a call, and meanwhile novices are playing with your life.

The new "Radio Paging Service" will do away with the greater percentage of these hazards. Application has been made to the Federal Communications Commission to set aside a six-kilocycle band in the 30-50 megacycle short-wave region, which will be used entirely for short-wave radio paging of doctors. It will be a method of signaling only those doctors who are wanted. No message or word of instruction is communicated to a doctor while en route. No one will talk to him; no voice will reach him. But, upon receiving a pre-set signal in his ear, the doctor is then required to hasten to the nearest telephone and ask the radio-paging service for his message. According to the Doctors' Telephone Service of New York City, which is sponsoring the idea actively, the receiving device to be carried by the doctor can be likened to the combination on a safe. Each receiving set has its own combination of numbers and, when this code or series of dots and dashes is sent out over the air, the radio receiving set of the particular doctor responds by setting off a buzzer or lighting a pilot lamp. As the pilot lamp and buzzer remain in operation until released by the doctor, it means that it is not necessary for him to concentrate any attention on his automobile receiver. Thus he may have been a half hour making a house call but, upon returning to his automobile, will find his signal in operation.

Such a receiving set has actually been built in the laboratory and successfully tried under actual operating conditions in New York City. It is the plan of the Doctors' Telephone Service to turn the building of these receivers over to some well-known radio manufacturers, who may be interested in placing them with doctors on a rental-and-service basis.

The waveband width need be no more than six kilocycles, since the coding requirements are for one or more modulating tones, each less than three kilocycles and operating at a comparatively low speed.

It is also possible, with adjacent communities having different code combinations, that each signal channel can be duplicated every one hundred miles without any interference.

The next issue of this magazine will be published under the new name of

SHORT WAVE and TELEVISION

Please note announcement on page 467. The next issue comes out December 1.

SHORT WAVE CRAFT, Published monthly at Mount Morris, Ill.
EDITORIAL and EXECUTIVE Offices, 99 Hudson St., New York City

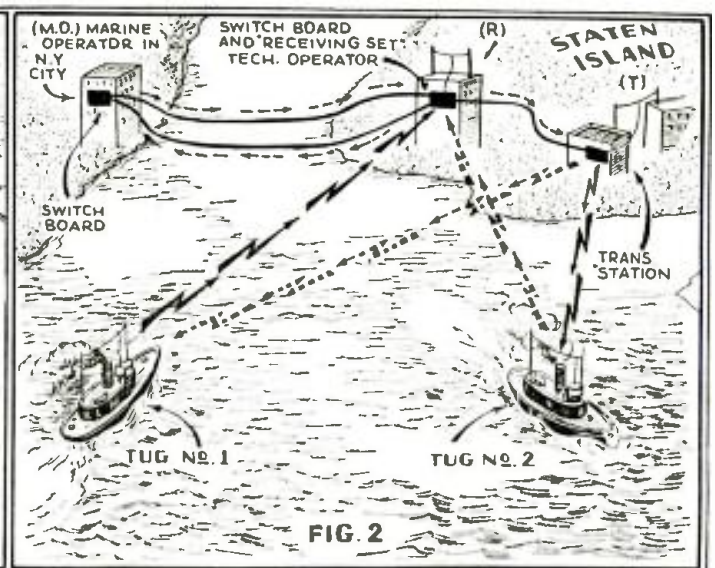
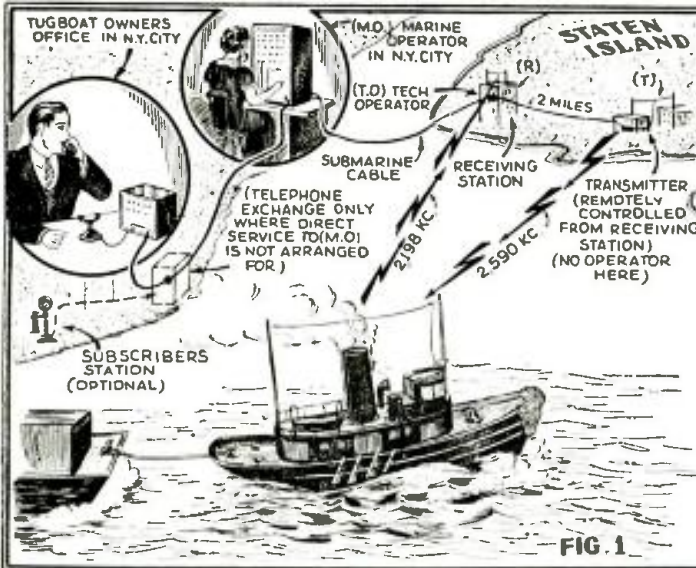

Diagram above shows how you may talk to a New York tugboat by "short-wave phone"; also how the captain of one tug may talk to that of another.

Even The Tugboats Go Short-Wave!

Short waves now enable the operator of a fleet of tugs to talk direct to the captain of a tug, and in like manner the captain of the vessel may call his home office for orders or advice. Furthermore, one tug captain may talk to that of another.

● PREPARATORY to establishing regular two-way radio telephone service for commercial craft in New York Harbor and nearby waters, the New York Telephone Company has been conducting an operating trial of equipment on seven boats engaged in freight transportation in the harbor. The tests are being made under experimental licenses issued by the Federal Government. Five of the boats are tugs owned and operated by the Pennsylvania Railroad. One of the other two is operated by the Oil Transfer Corporation and the other by the Socony Vacuum Company. When the service is opened to the public, after the trials conducted jointly by the telephone company and the transportation enterprises, it is expected to be widely used by various classes of harbor vessels. It might also be used by

certain vessels operating in Long Island Sound and on the Hudson River.

Two-Way Service to Any Land Phone

The period of trial operation of the harbor radio telephone system is now drawing to a close and has resulted in many improvements and advances in the art which will make it possible to offer a high-speed efficient service for the towing companies in New York Harbor, so that two-way conversations can be carried on between harbor vessels and their dispatchers quickly and easily at any time during the day or night. Connections, when desired, can also be made to any land telephone. The new Western Electric radio-telephone equipment, said to be the most up-to-date and efficient yet developed, has been tested thoroughly and adjusted to meet the needs of customers for this service. The complete system is now working smoothly in connection with the normal operation of the towing companies.

Shore Station Has 400-Watt S-W Transmitter

Radio shore equipment installed by the telephone company includes a 400-watt short-wave transmitting station atop the building at 25 Hyatt Street, St. George, Staten Island. A receiving station is located nearby on the island with facilities for inter-connecting the radio voice ways with the telephone company's regular land wires.

During the trial the seven harbor boats are communicating to designated points ashore under the direction of the telephone company. These tests supplement earlier ones made by the telephone company with its own cable-laying boat



Featuring acting captain, Ole Walen, of the tugboat, "Samson," at pier No. 7, Tomkinsville, S.I. using his radio-telephone to call the office for instructions.

Right: Apparatus necessary to provide radio telephone service in connection with tugboats. This photo was taken on the tugboat "Lancaster," at the pier of the Penn. R.R. Co., Hoboken, N.J.

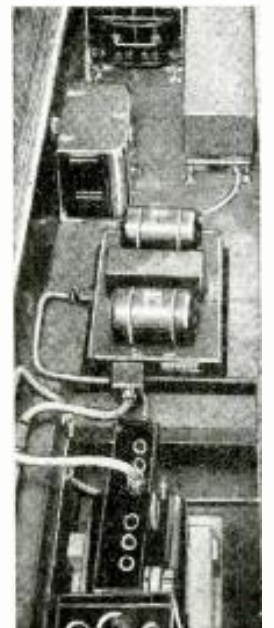

and have provided further necessary operating experience.

Ship-shore radiophone equipment and service have been developed steadily during the past five years, meeting a growing demand for two-way voice communication with ships. A score of transatlantic liners have adopted the service since the first installation was made aboard the steamship Leviathan in December, 1929.

Plans for Radio telephone service for the nation's greatest seaport and water transportation center—New York City—have been under way for several years. Upon (Continued on page 503)

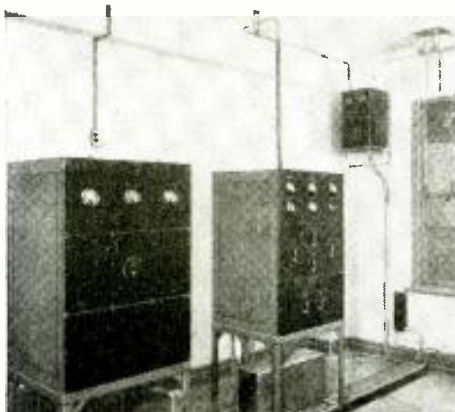

Transmitter Equipment—located at St. George, S.I. Operation is by "remote control" from the receiving station at Rosebank, S.I. Left to right—2 transmitters, on wall-tuning unit, on ceiling—antenna cutout.

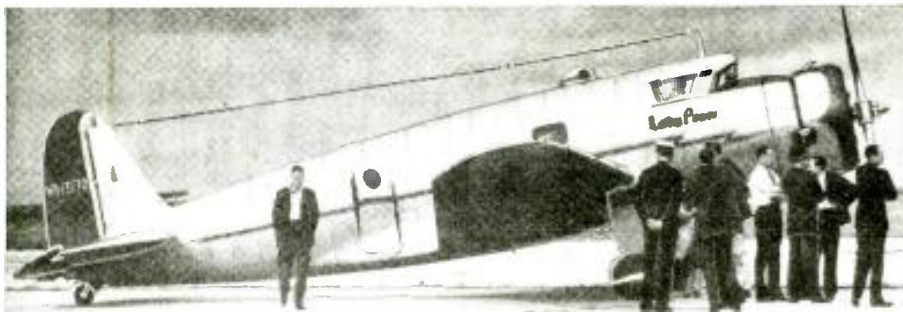

Side view of Harry Richman's trans-Atlantic plane "Lady Peace," showing antenna installation for the radio equipment. Pilot Dick Merrill may be seen near the ship's tail.

Short Waves Kept "LADY PEACE" In Touch With Land



Model 12A aviation radio receiver used by Harry Richman and Dick Merrill at right. Model 13C Transmitter at left.

● DURING the latest record-breaking trans-Atlantic airplane hop, Harry Richman, famous night club vocalist and Dick Merrill, veteran pilot, kept in constant touch with the outside world through their modern Western Electric radio installation aboard the "Lady Peace." From start to finish the flight was a radio epic. Broadcast station WOR stayed on the air all night September 2-3 in order to furnish the anxious public with hourly bulletins received at the Newark Airport radio station for the Trans Radio Press. These communications were also immediately put on the teletype and flashed across the country.

Previous to the take-off, the WOR staff obtained recordings of Harry Richman and of Dick Merrill as they voiced their farewell messages to America, and the roar of the plane taking off furnished a fitting climax to the record. This material was subsequently broadcast at intervals during the night as

the station's listeners waited for news of the flight. Moreover, an Eastern Air Lines' plane equipped with a *short-wave* radio transmitter and receiver was dispatched to (Continued on page 500)

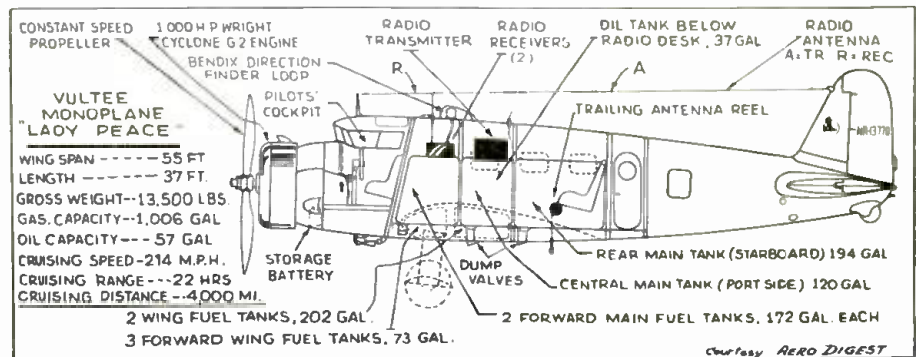
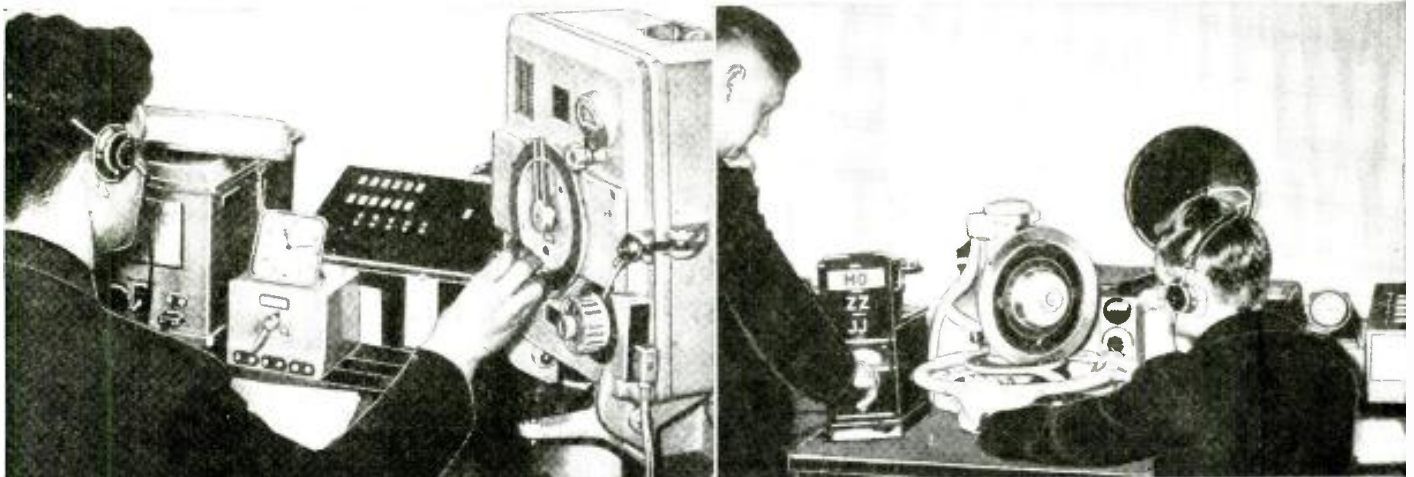

Diagram of the Vultee monoplane "Lady Peace" in which Harry Richman and Dick Merrill established a new world's record for speed in crossing the Atlantic. Note position of radio equipment and aerials.

Short Waves, Plus Strings, Guide Planes



The photo at left shows short-wave transmitter by means of which the operator gives the airplane pilot his exact position. Photo at right shows new German short-wave apparatus used to guide flyers. The wheel shown in the photo rotates the directional antenna on the roof of the building.

● EVERY month or so the newspapers blazen out the horrible details of an aviation crash. It is extremely rare that we hear of an accident of this type occurring in Germany. Over here we have short-wave radio and radio beams—the latest instruments used in *blind flying*, but the disasters still persist. The commercial aviation companies frequently lay the blame on the radio beams operated by the Government. The Government throws the blame back on the shoulders of the aviation companies and the accidents continue.

The Germans have evolved a system

of checking positions of aircraft which is almost perfect. The lack of perfection lies in human frailty connected with the aviator in charge of the plane. Every other detail is taken care of by the ground stations situated along the routes prescribed for the German Commercial aviation. As in all countries up until recently—fog, sleet, and "thick" weather were serious obstacles to aviation. All of the countries have been making rapid strides in *blind flying*. They have been devoting millions of dollars in equipment in the training of men, but as far as the United States is

concerned, this has not been enough.

As far as Germany is concerned today, flying and landing in the worst kind of weather is no longer anything unusual. Special arrangements, prominent among which are the radio installations for Government planes, provide that any aircraft flying *blind* is practically led in to the airport safely. Strange as it seems, they are led in by *strings!*

A small building at the edge of the airport, the ground location from which bearings are given, takes care of the safety of the (Continued on page 507)

What I Saw at the New York RADIO SHOW—

By "Spectator"

● THE biggest feature at the New York Radio Show was, undoubtedly, the Crosley huge all-wave receiver—suitable for use in restaurants or large mansions—and in which 37 tubes operate six loudspeakers! The set was priced at \$1,500.00 and was fitted into a very handsome cabinet. An extra large dial enables the operator to tune in short or broadcast range stations from any part of the world. By means of the six loudspeakers, faced in different directions, the complete treble, mezzo, and bass frequency notes are thoroughly covered.

The general trend of receiver design, apparent in all the new models exhibited at the Show, was in the direction of "bigger and better" dials. Most of the sets this year were all sporting the large, clearly readable dials, and some of them employed a number of lamps, which—when switched on—show different colors for each scale. The numbers or the station initials are rendered much more legible, thanks to these new

large-size dials. Some form of tuning meter or electric tuning "eye" is fitted to most of the console models.

One table model receiver has an electric clock fitted in the rear face of the cabinet, and both front and rear of the cabinet are finished alike. Where such a model is used on a table in the center of the room, this is a very attractive feature.

We predict, as time goes on, that a small electric clock will become a standard feature of many sets.

Several of the sets exhibited had a dial similar to that on the dial type telephone, so that by placing your finger in an opening bearing the letters of the station desired, and twirling the dial, the station

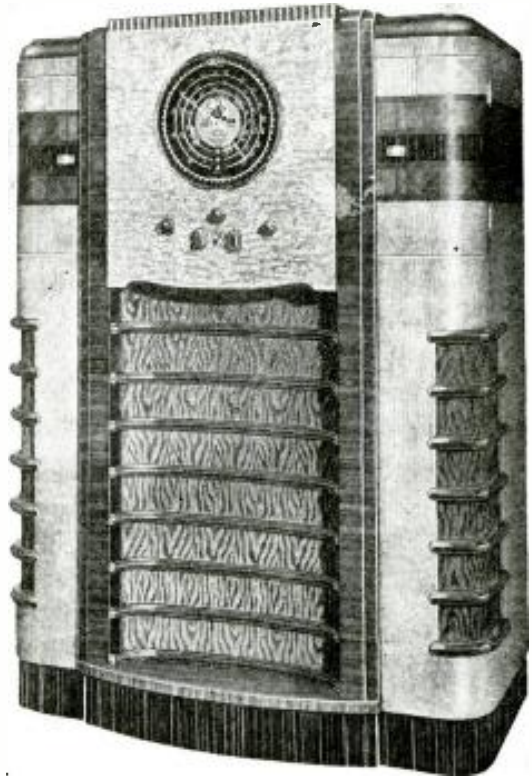

The outstanding feature of the recent New York "Radio Show" was the Crosley 37-tube receiver, fitted with six loudspeakers, to cover the various sound ranges—including the bass, mezzo, and treble.

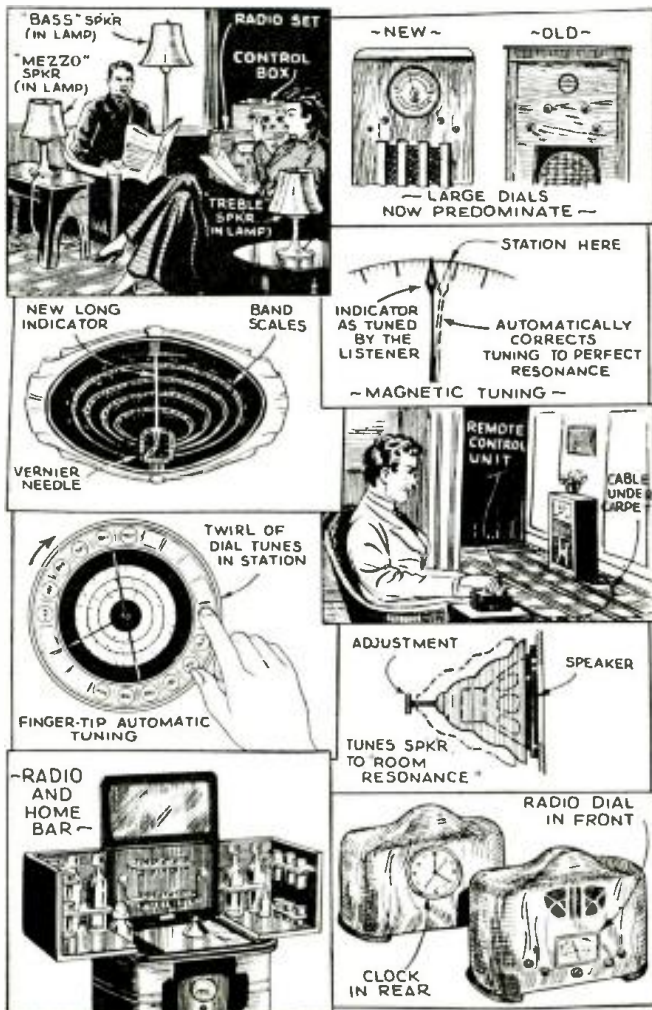

would automatically be "tuned in." One of these dials was about 10 inches in diameter and had finger openings for fifteen stations; any one of these stations could, of course, be "tuned in" instantly by merely twirling the dial.

A novel loudspeaker feature incorporated in one of the sets we saw, involved the use of a large metal drum or shield which fitted over the rear of the loudspeaker. By

Features—37-tube, 6 loud-speaker receiver; new and bigger all-wave dials; tuned speakers; Radio-bar.

means of a knob on the rear of the speaker, this drum or acoustic balancing chamber could be moved back and forth and thus vary the sound effect produced from the set.

Magnetic tuning was another feature shown and this will undoubtedly become a "stock item" on the better class sets during the coming year. This feature makes sharp tuning unnecessary; if you tune the station in roughly with the indicator only approximately over the right point on the dial, the new device does the rest and finishes the tuning at once to a fine degree.

A new feature took the form of "loudspeaker lamps"; you are supposed to buy three of them in order to cover the complete tonal range. These lamps have loudspeaker units built into them and have elaborate metallic bases of different lengths, so that one lamp covers the bass, another the medium range, and a third the treble or higher frequency notes. By suitably locating three of these lamps about your living room, and adjusting the control box which comes as part of the equipment, you can get a very excellent blending of the music. The objection of having all the sound seeming to come from one spot is thus eliminated. When using the "lamp-speakers" the regular speaker in the set is cut out; these "talking lamps" may be connected to any receiving set.

Bigger and better radio-bars (Continued on page 505)

A number of interesting departures in radio set design were noticeable at the New York "Radio Show." The illustrations above give some idea of these new designs. One set has a clock in the rear of the cabinet—dials were much larger than on previous designs—precision "magnetic tuning" is a new feature—also automatic tuning of the major stations.



O. B. Hanson, Chief Engineer, National Broadcasting Company.

NBC's Chief Engineer O. B. HANSON

Discusses TELEVISION & SHORT WAVES

In an Interview By H. W. Secor

The letters, NBC, are synonymous with *broadcasting* to every radio listener in the Western Hemisphere, at least. The man responsible for solving the many technical problems which arise in the daily operation of this vast network of broadcast stations, extending across the country, is O. B. Hanson, Chief Engineer.

Mr. Secor's interview with Mr. Hanson will undoubtedly throw a new light on many short-wave and broadcast angles for many of us.

Opportunity in Engineering

As thousands of young men are interested in technical schools and colleges with the idea of completing a course in electrical or radio engineering, I asked Mr. Hanson whether he thought that the student with these ideas in mind would do best to follow a strict course in engineering or whether, thinking of the many executives who combine engineering ability, he possibly had best include a business training course with his technical subjects.

Mr. Hanson was quick to emphasize the fact that he believed that the young man thinking of radio engineering as a career, had best stick to engineering subjects. "We are moving so fast today in radio," said Mr. Hanson, "that he will need to devote every bit of time he can to the study of engineering subjects. If the student expects to make a success of engineering work today, he had best specialize along those lines."

What are the advantages of NBC's "Red" and "Blue" networks? I asked Mr. Hanson.

"The 'Red' and 'Blue' networks give us the opportunity to have two different broadcast stations in the same city, for example, one broadcasting one type of program while the other is broadcasting another type program, both on different wavelengths or frequencies. We did not originate this system but it was a heritage which dates back to the time NBC was formed, the 'Red' network having been started by the A. T. & T. Co. and the 'Blue' by RCA. The newly formed NBC (1926) took over the broadcasting activities from those companies and has continued the two networks up to the present time."

In answer to a question, Mr. Hanson stated that it was only on rare occasions that both networks were employed by the sponsor, but in exceptional cases, such as when the President speaks, the combined networks had been used.

Do you think the broadcast frequency band may be extended eventually either below 200 meters or above 550 meters? I asked.

Mr. Hanson explained that this question, of course, would be up to the decision of the Federal Communications Commission at some future date, if and when the subject might be brought up for consideration. He mentioned however, that if we go above 550 meters we would run into the present international ship frequency channels, and so far as going below 200 meters, there was the technical consideration that the ground wave attenuation increased to a marked extent; for this and other reasons there would most likely not be a great desirability of attempting to extend the present Broadcast band below 200 meters.



● ONE of the greatest networks in the world is that operated by the National Broadcasting Company, known to all by the mystic initials, NBC. The mere sight or thought of these initials immediately reverts the mind to brass bands, concert singers, and the voices of famous personages and comedians bursting forth from your loudspeaker, while you may loll in your favorite easy-chair with the evening paper which inevitably completes the picture.

SHOULD EMBRYO ENGINEERS STUDY BUSINESS AND TECHNICAL SUBJECTS?



Have you not often wondered just who was responsible for all of the technical details of such a marvelous combination of radio and electrical inventions which today make possible the phenomenon of modern broadcasting?

Mr. O. B. Hanson, Chief Engineer of the NBC, graciously welcomed the writer to his office in Radio City, the center of all NBC activities. Mr. Hanson not only has to be thoroughly conversant with the very latest developments in radio and electrical engineering, but at times he is required to break away from his routine and take a trip to Europe or outlying parts of this country, in order to keep in touch with the newest inventions and developments. This provides an engineer in Mr. Hanson's position with an excellent mental "yard-stick" by which to gauge the quality and performance of American broadcast stations, as against those of the other countries.

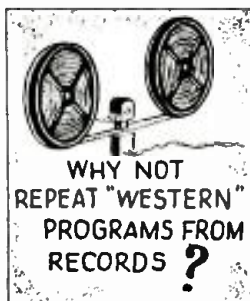

Wired Radio

What is your opinion of "wired" radio?

"At the present time there does not seem to be very much activity in this direction. The principal objection to sending programs over an electric light or power wire system is that it is uneconomical, both from a technical and program standpoint. Also, this method of transmitting voice and music by superimposing carrier frequencies on such wire lines, runs into a number of technical problems, for instance static noises caused by the opening and closing of switches in power stations, surges in the lines, 'hum' from one or a number of sources, noises caused by the operation of electrical motors and other machinery connected with the circuits," said Mr. Hanson. Even though the writer pointed out to Mr. Hanson that (Continued on page 498)

Hoover "TINYMITE" The Smallest S-W Receiver



Mr. Hoover is shown actually listening to phone conversation between airplane pilots and "ground" stations, at Rochester, N.Y., on the "smallest" 1-tube radio set with a 7-foot aerial.



Quite a number of "small" short-wave receivers have been built and described, but the Hoover "Tinymite" is of more than ordinary interest for the reason that it has brought in stations from every imaginable quarter of the globe. This receiver works on the self-quenching super-regenerative principle and it uses a single 955 "Acorn" tube. Small batteries operate the set, the plate working very well on as low as 45 volts. Usually a 7 ft. length of No. 36 copper wire serves successfully as the "antenna," no ground being necessary. With the coils specified, the tuning range is about 49 to 75 meters.

Left — the small size of the "Tinymite" will be realized by a study of these photos.

● WELL, here it is, the "smallest" 1-tube radio set. It measures only 2½ inches long by 1 17/32 inches in width and 1¼ inches deep. The panel is made of white celluloid.

The variable condenser is a Hammarlund APC 50 mmf. midget, which tunes in the stations. The coil is a home-made "jumble-wound" coil of the duo lateral type; it consists of 33 turns of No. 36 B & S gauge D.S.C. for the secondary, and 33 turns of No. 36 B & S gauge D.S.C. for the tickler, wound on a ¾ inch bakelite ring. It was found that the tickler worked better if wound in the reverse direction from the way the secondary was wound; the windings should be spaced ¼ inch. After the coil is wound it should be painted with finger-nail polish to hold wires in place.

This dries quickly and protects the wiring.

A 955 tube is used with the heater and negative filament grounded. This tube is held tightly in place by a prong screwed on the panel to which one of the tubes leads (negative A) is soldered. (Clamping is recommended as the heat of a soldering iron is liable to loosen the glass seal in the tube and ruin it.—Editor.) A shield is placed between the variable condenser and the panel, and a miniature .0001 mf. condenser is used for the grid capacity, with a 1 megohm miniature grid-leak; a .001 mf. fixed condens-



er is used as a regeneration condenser.

A 35 mmf. Hammarlund variable condenser is mounted on the front of the panel, and to which the aerial is attached. This condenser requires a very careful adjustment.

The set is a super-regenerative and works well over a range extending from 49 to 75 meters, on a seven foot indoor aerial of No. 36 copper wire. On smaller aerials it will tune to as low as 20 meters.

A 6-volt railroad lantern (dry) battery is used for "A" current, (or any suitable substitute). On these lantern batteries the spring in the center is negative and the outer edge contact is positive. Forty-five volts are required for the plate, although it will work on 66 or 90, but it seems best on 45. The tube heater consumes but .16 amperes.

At Rochester, N.Y., Mr. Hoover, the designer and constructor of the "Tinymite" received one CQ phone call from Europe. EAM and EAQ came in good in code; these stations are located in Spain. Albany, Chicago, Newark, Cleveland, Omaha, Toledo, Indianapolis, Tarrytown, and Salt Lake City aeroplane ground stations were received at Rochester with good headphone volume.

(Continued on page 505)

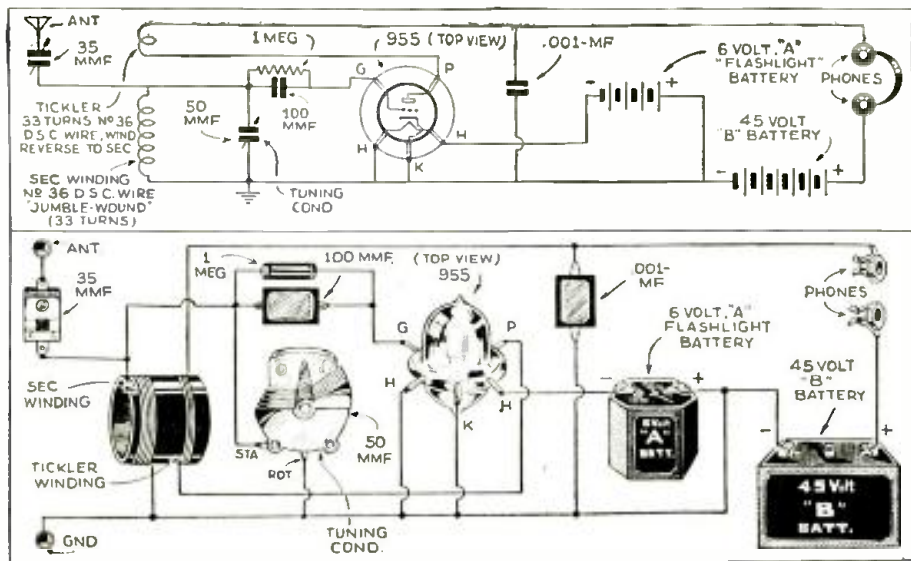

Wiring diagram as used in building the "Tinymite." Set has a range of 49 to 75 meters.

SHORT

THIRTY-THIRD TROPHY CUP

Presented to

SHORT WAVE SCOUT
WALDORF R. GUENTHER
 1906 N. 35th St.
 Milwaukee, Wis.

For his contribution toward the advancement of the art of Radio by



Magazine

33rd TROPHY WINNER

138 Stations—121 Foreign

● THE thirty-third Trophy Cup has been awarded to Mr. Waldorf R. Guenther for his efforts in DX'ing and obtaining verification cards. Mr. Guenther had a total of 138 verification cards, all of which came within the rules of the contest.

Many "Fans" will be interested to know that Waldorf Guenther's home-made receiver with a superhet. employing one stage of R.F., oscillator and first detector; two stages of I.F. at 465 kc.; another detector and oscillator operating at 290 kc.; another 6A7 beating the 465 kc. I.F. down to 175 kc., followed by two more I.F. stages; a diode second detector AVC and first audio circuit, then a second audio Class "A" driver for a 59. The output stage was a pair of 53's in push-pull, Class "B" with a 15-inch dynamic speaker and provisions for heterodyning CW signals with a beat oscillator. It was constructed around a Tobe tuner and used National air-tuned I.F. transformers. Most amazing of all, the only antenna Mr. Guenther employed was a steel bed-



WAVE SCOUTS

Honorable Mention None this month

spring. Mr. Guenther submitted the only entry for this particular contest. So take off your coats, boys, and get busy. We want a lot of entries for the next issue. Remember the dead-line—all entries for the February issue must be in the judge's hands by midnight of Nov. 25.

UNITED STATES STATIONS
 CALL FREQ. IN KC. NAME OF STATION

W1XAL	11,790	University Club, Boston, Mass.
W1XAL	6,040	University Club, Boston, Mass.
W2XE	15,270	Atlantic Broadcasting Co., New York City.
W2XE	11,830	Atlantic Broadcasting Co., New York City.
W2XE	6,120	Atlantic Broadcasting Co., New York City.
W2XAD	15,330	General Electric Co., Schenectady, N. Y.

(Continued on page 513)

● ON this page is illustrated the handsome trophy which was designed by one of New York's leading silversmiths. It is made of metal throughout, except the base, which is made of handsome black Bakelite. The metal itself is quadruple silver-plated, in the usual manner of all trophies today.

It is a most imposing piece of work, and stands from tip to base 22½". The diameter of the base is 7¾". The diameter of the globe is 5¾". The work throughout is first-class, and no money has been spared in its execution. It will enhance any home, and will be admired by everyone who sees it.

The trophy will be awarded every month, and the winner will be announced in the following issue of SHORT WAVE SCOUT. The winner's name will be hand engraved on the trophy.

The purpose of this contest is to advance the art of radio by "logging" as many short-wave phone stations, amateurs excluded, in a period not exceeding 30 days, as possible by any one contestant. The trophy will be awarded to that SHORT WAVE SCOUT who has logged the greatest number of short-wave stations during any 30-day period.

SPECIAL ANNOUNCEMENT

By Hugo Gernsback

EVER since SHORT WAVE CRAFT was established in 1930—almost 7 years ago—we continuously included various information on television in its pages.

Of late, television developments have become of such importance that we found it necessary to devote one or more pages nearly every month to the rising tide of television.

Short waves and television are so closely linked that they have become inseparable, and at the present state of development of the art, it seems unthinkable that in the future we could have television without short waves, and vice versa.

For that reason, I have thought the time ripe to incorporate the name of TELEVISION into the title of the magazine, and beginning with the January issue, SHORT WAVE CRAFT will be known as SHORT WAVE & TELEVISION.

It should be thoroughly understood that in making this change of title, no editorial change in the magazine is contemplated.



The magazine will remain exactly as it was before, and it will report as accurately and as quickly as humanly possible the happenings in the short wave and television field.

The change of title was made, first, because the time is now ripe to have the general public's attention drawn to the immense possibilities of Television. Secondly, many of our readers are giving increased attention to television, which is reflected in their letters to us. Third, at the present time there is no popular technical magazine in the United States which continuously reports progress on television, and in view of the recent advances in the art, it was thought logical to have SHORT WAVE CRAFT assume the lead in the technical magazine field.

The editors will be happy to have your views as to the change of name, and they shall be glad to publish the most interesting letters received.

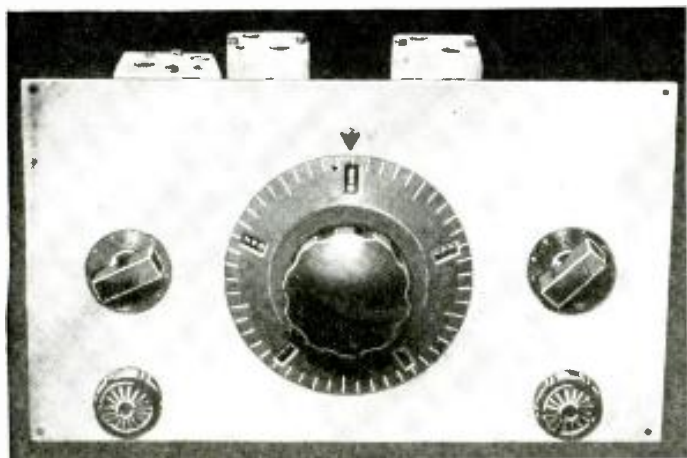

Front view of the 6 metal-tube 5-meter superhet.

● COMMENSURATE with the improving conditions in the ultra-high frequency amateur bands, every one agrees that the equipment we use must be brought up to date. In past articles the writer has described ultra-high frequency transmitters, which go a long way toward modernizing the entire ultra-high frequency set-up. Elsewhere in this issue will also be found an improved transmitter for operation on the 5-meter band. With these improved transmitters there must naturally come improved receivers. The one described in this article is a result of many months of careful experimenting. We have endeavored to incorporate in it features which would make it appeal to the average 5-meter enthusiast.

Some of these features are standard tubes and all standard equipment wherever at all feasible, and the lack of circuit complications. Naturally one could build a receiver with several stages of R.F. amplification, employing Acorn tubes. Here at once we encounter the real problem of making these circuits behave and tune in an orderly manner. Our idea in this receiver was to keep the ultra-high frequency portion as simple and brief as possible, in order that the set might be popular with the average "ham." The well-known resistance coupled "Super" was popular for the simple reason that a single ultra-high frequency stage was all that was required.

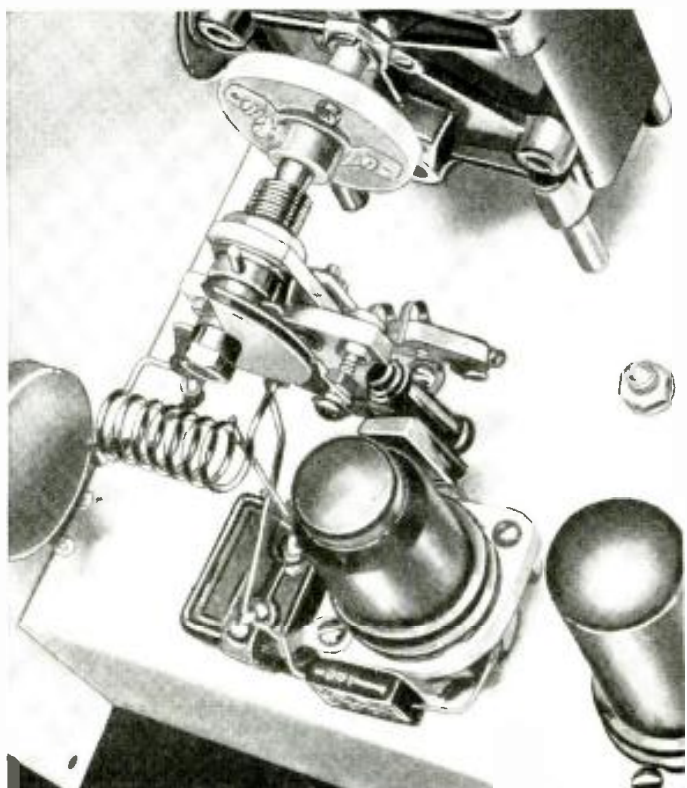

A view of the oscillator tube and its tuning circuit.



A "REAL"

By George W. Shuart, W2AMN

Seriously-minded 5-meter amateur will find this superheterodyne an ideal receiver. It has plenty of selectivity as compared with the conventional type 5-meter receiver and is capable of bringing in the fairly weak stations with full speaker volume, because of its high sensitivity. The radio frequency portion of this receiver may be coupled to a television amplifier for use in experimental television set-ups.

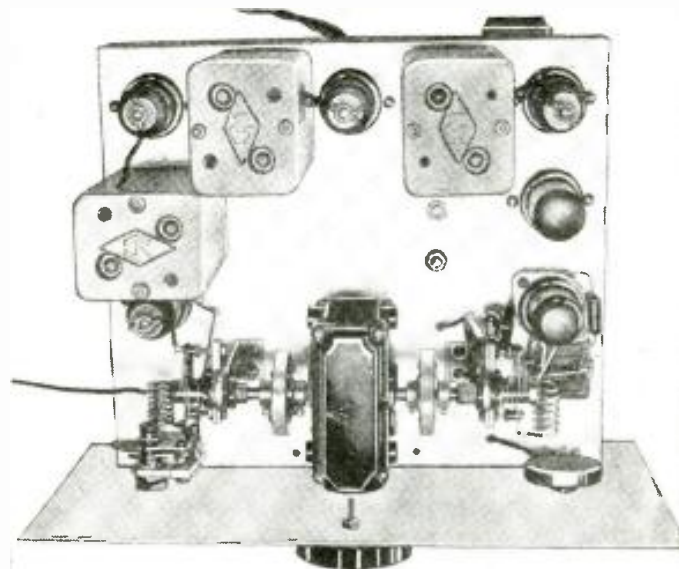

Note the neat construction and efficient layout.

Set Has Remarkable "Gain"

The converter circuit used in this receiver consists of a 6A8 and a 6C5. This same circuit was featured by the writer for use on both 10 and 5 meters in past issues of *Short Wave Craft**, and today we have yet to see a more simple arrangement which would give anywhere near the gain obtainable with this combination. The gain is undoubtedly due to the regenerative effect which takes place in the 6A8 detector and which is perfectly *controllable*. This cannot be said of the usual regenerative circuit because we all know that they are quite erratic and uncontrollable in the ultra-high frequency region.

So much has been said in previous articles regarding this converter that we feel the diagram and the brief foregoing statements are sufficient.

To make this receiver broad in selectivity we have used an intermediate frequency of approximately 4,000 kc. While this permits quite a wide band width, it is really necessary for two very good reasons. First, it will be quite some time before all signals on 5 meters are *absolutely* stable and these require a receiver with quite a wide band. Remembering that if we use crystal control, even on 5 meters, there will be "creeping" in the low-frequency crystal stage and this creeping is multiplied with the frequency doublers, and it is very easy for the crystal controlled signal to creep 5 or 6 kc. The wide band receiver permits reception of such signals *without retuning!* Another reason for the necessity of a wide band receiver is directly concerned with the stability or lack of stability in the high-frequency oscillator circuit. It is practically impossible to maintain stability in this circuit within 10 kc., regardless of the circuit or tube used, and immediately we see that a 10 kc. super would have to be retuned occasionally because of oscillator frequency shift. So from all appearances it would seem that a 20 or 30 kc. band width is an absolute necessity and a width of 40 kc. highly desirable.

"I.F." Transformers—How Built

The I.F. transformers are constructed around National

*May and Oct. '36 issues.

5-METER SUPER-HET

A Simple Band-Spread Receiver for Ham and Television Reception

F.X.T. tuning units which could not suit the job better if they had been designed for this particular purpose. The dimensions of the coils are clearly shown in the drawing. Only two stages of I.F. amplification were required in this receiver. The first thought, naturally, was that two stages at this high I.F. would not provide sufficient gain. However, coupled with the gain in the converter circuit these two stages proved to provide more than useable gain. With the general background noise and the noise originating in the 6A8 detector it is impossible to turn the gain of this receiver to more than 80 per cent of maximum. The single 6F6 pentode audio stage also proved to supply more than sufficient volume, on even the weakest of signals, to operate the dynamic speaker to more than comfortable room volume; consequently, the A.F. gain control was incorporated.

By-Pass Condensers and Filter Resistors

In the circuit diagram we have shown every by-pass condenser and filter resistor required—none should be left out and none should be added. The values should be followed carefully within close limits. In the high-frequency portion an effort was made to keep all leads as short as possible. The coils were mounted directly on to the condensers. In the detector and oscillator sockets a lug is placed under one screw both above and below the chassis. The grounding connections made above the chassis associated with the oscillator circuit for instance all go to (Continued on page 502)

The first detector tube and its tuning circuit.

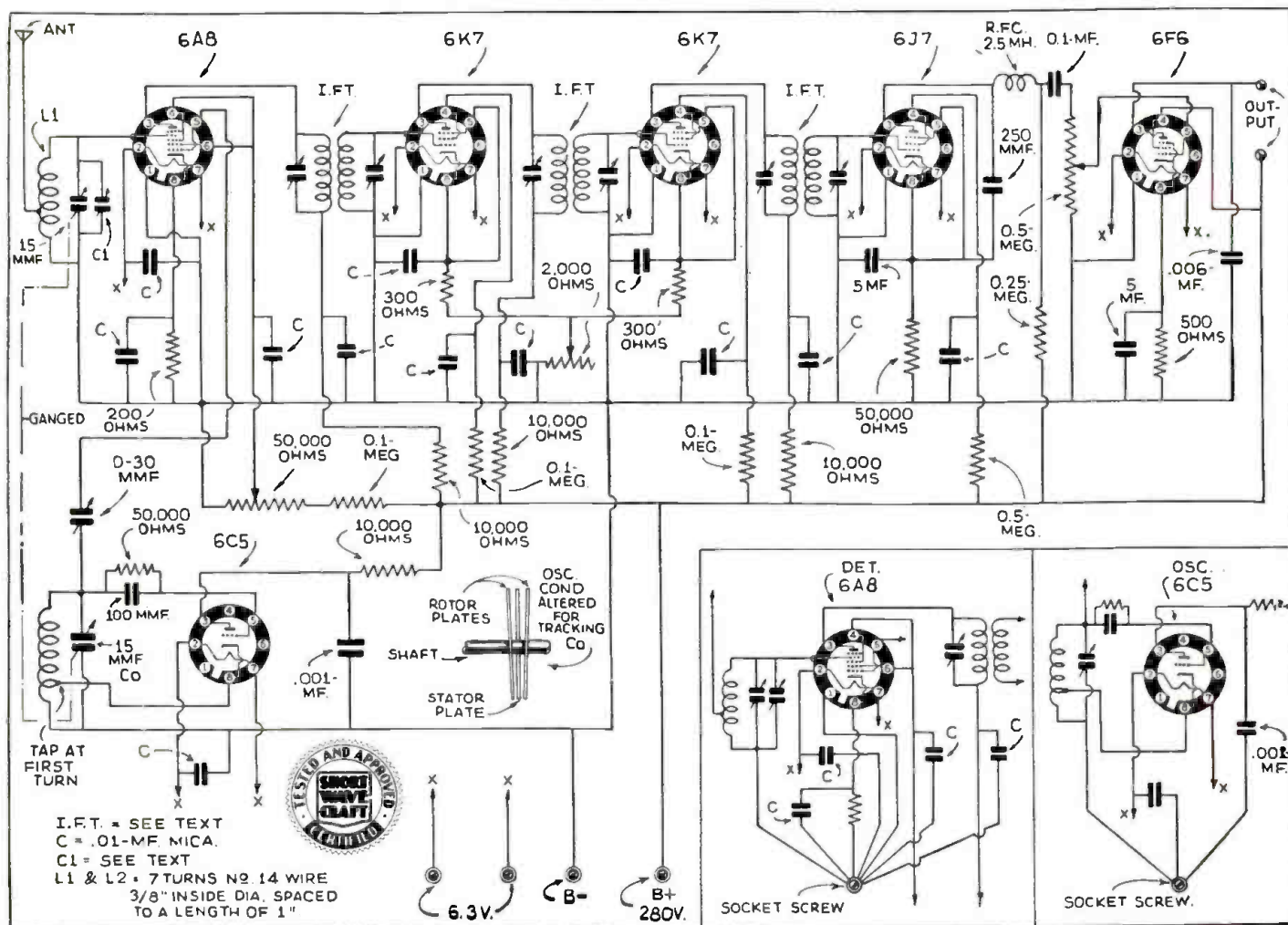
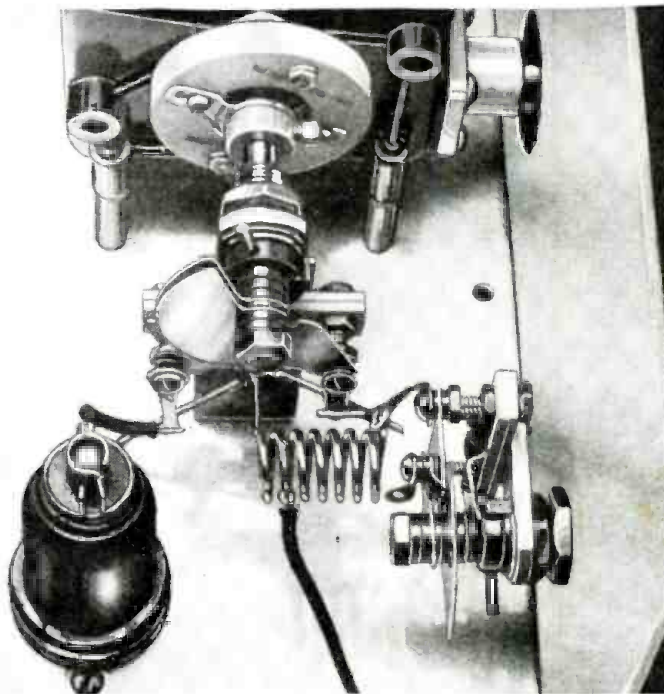

Wiring diagram of Mr. Shuart's 6-tube 5-meter superhet.

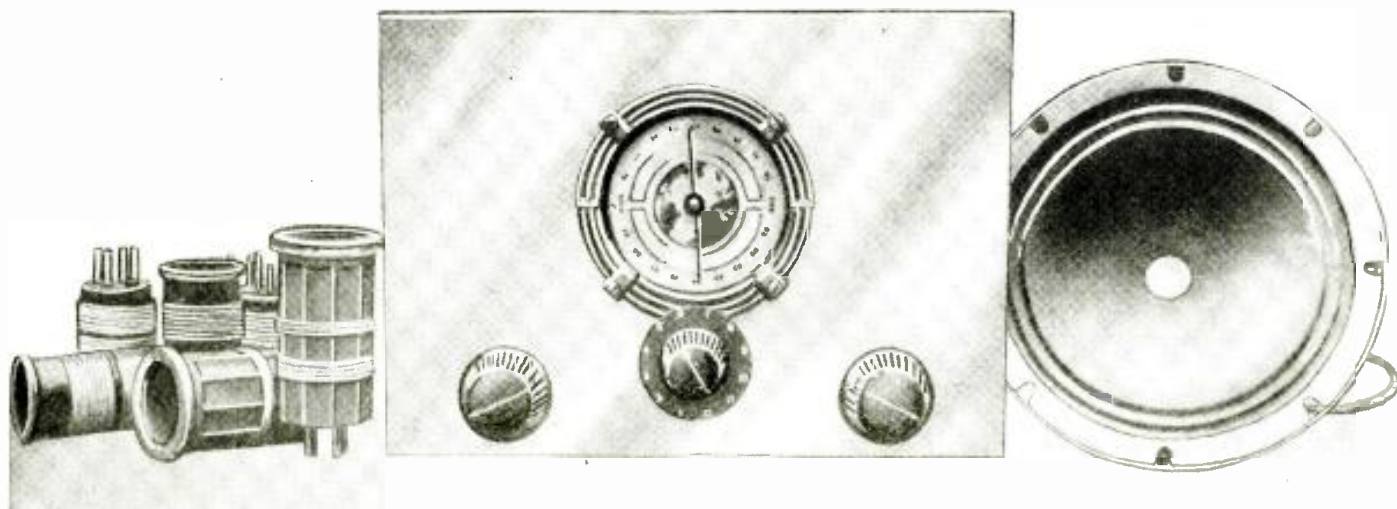

A front view of the 2-volt superhet, which uses but 4 tubes to provide many features only found in much larger and more costly receivers.

The "2-Volt" Super DX-4

By Harry D. Hooton, W8KPX

● THE "2-volt" short and long-wave superheterodyne illustrated and described in this article is the result of several months of intensive experimental work with various circuits of this type. Although designed primarily for general *short-wave* use, it is equally suitable for either "fan" or "ham" purposes and is an excellent DX-getter for the fellow who lives in a rural district, where commercial power service is not available.

Among the features of this receiver are: Complete coverage of all wave-lengths from 12 to 550 meters (25,000 to 545 kc.), continuous band-spread on all frequencies, automatic volume control, with an "off-on" switch for cutting out the AVC action when not desired, provision for using a *beat-oscillator* for the reception of unmodulated code signals, and last—but not least—the flexible "plug-in" method of changing coils which does not limit the tuning range of the receiver to a few bands only.

1C6 Used as Mixer and Oscillator

As the circuit diagram, Fig. 1, shows a 1C6 is used as combined mixer and oscillator, a 34 as a 456 kc. I.F. amplifier, a 32 as a combination second-detector and AVC tube, and a 19 as a two-stage audio amplifier. In working out this circuit, the author has tried to obtain the maximum amplification which the above tubes are capable of supplying, and yet keep the finished receiver as simple and inexpensive as possible.

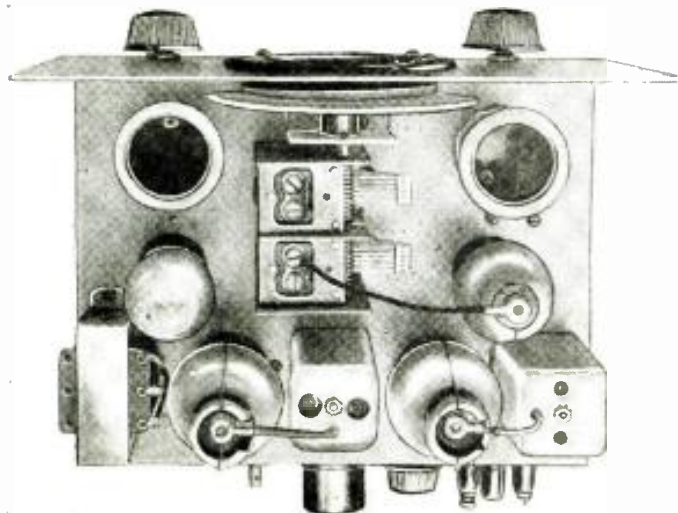

Rear view of the 2-volt Super DX-4—which has a wavelength coverage of from 12 to 550 meters, or 25,000 to 545 kc. It also has A.V.C.

This small but extremely useful superhet. receiver, using four 2-volt tubes, covers the usual short-wave as well as the 200 to 550 meter broadcast bands. It can be operated from dry cells, storage batteries, or A.C.; has continuous band-spread, automatic volume control, and a switch for cutting out the A.V.C. when not desired. Provision is made for using a beat oscillator for the reception of unmodulated code signals.

For economy the plate voltage has been limited to 135 and the filaments of the tubes are wired in a series-parallel arrangement, which reduces the "A" battery current drain 50% as compared with the conventional parallel connection. The heater supply may be either three ordinary dry cells connected in series or a four or six-volt storage battery. If the storage battery is used, the 150 ampere-hour size will last at least 5 or 6 months* before recharging is necessary since the drain is only 0.26 ampere at 4 volts.

Arrangement of Controls

The receiver, as the photographs and drawings show, is built up on a 7x9x2 inch electrical alloy chassis and a 7x10 inch aluminum panel. The controls on the front panel, reading left to right are as follows: "Sensitivity" control, AVC "off-on" switch, band-spread and tuning dials, filament "off-on" switch and audio volume control. The 15 ohm filament rheostat and the various binding posts, power plug, speaker and phone jacks, etc., are mounted on the rear of the chassis, where they will be out of the way. Complete data for cutting and drilling both the front panel and the chassis can be obtained from Fig. 2.

Before the parts are mounted on the chassis the photographs and drawings should be inspected closely. All of the parts used in this set have been mounted in the position which gives the very shortest and most direct leads, and this is especially true of those in the R.F. and I.F. circuits. In wiring, it is important that the following precautions be observed: (1) Make the grid leads as short as possible and keep them away from other grid or plate wires. (2) Keep the leads from the plates of the 1C6 and 34 tubes to the coils and I.F. transformers *very short* and see that they lie right against the chassis. This limits their external field and reduces *intercoupling*. (3) Mount the tubular paper condensers right on the parts they "by-pass." keep their leads short and direct and ground them to a *single length* of bus wire. The end marked "outside foil" or having a band goes to the ground. (4) Ground each section of the tuning condenser to the chassis with short, flexible

*However, storage batteries of the ordinary lead-cell type should be given a freshening charge about every four weeks.—Editor.

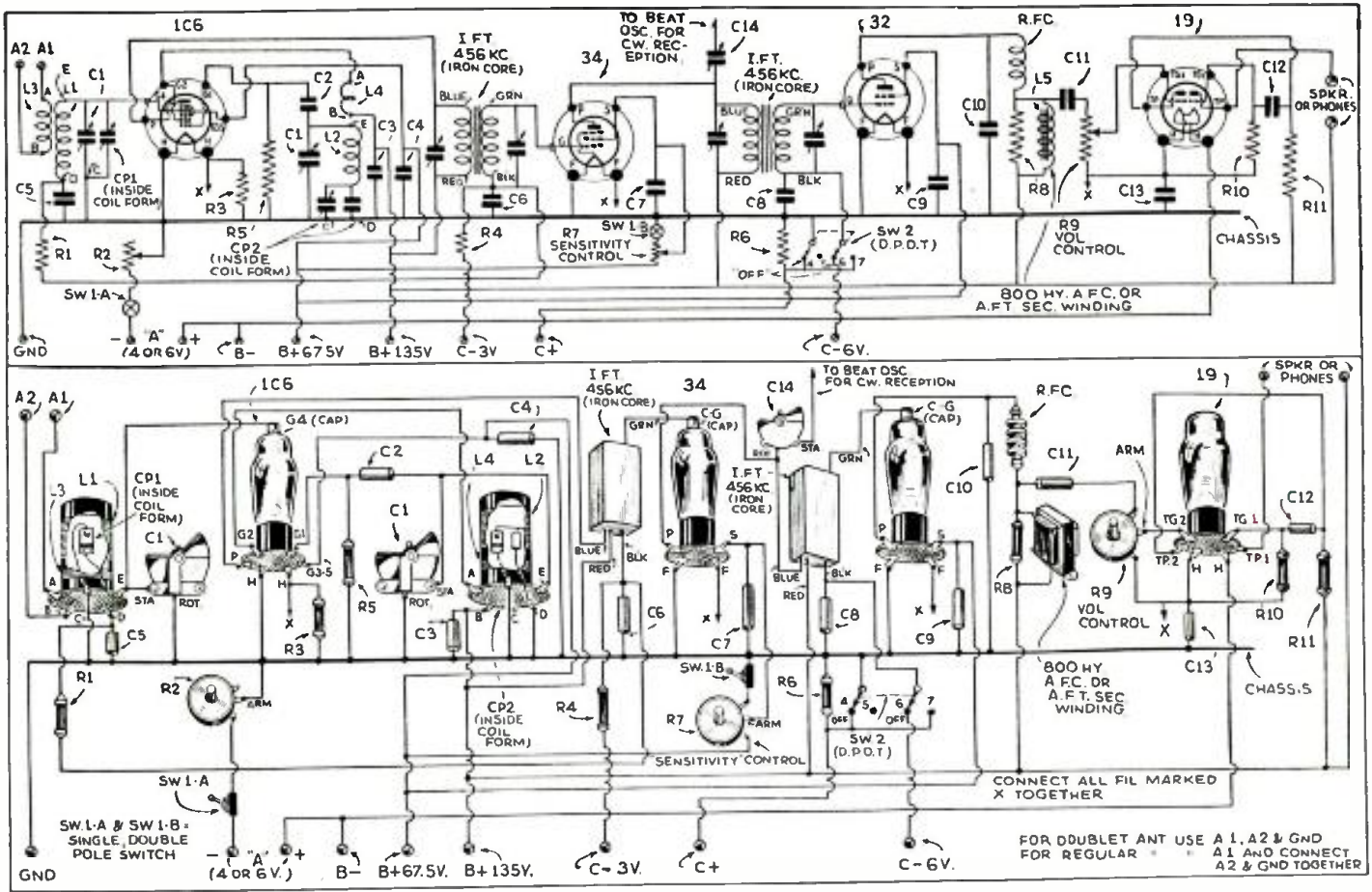

The short-wave experimenter "who likes to build his own" will find this 2-volt, 4-tube job simple to build and capable of giving surprisingly fine results. It has "hand-spread" 'n everything!

leads and solder each and every electrical connection in the receiver with a hot, well-tinned and clean iron and rosin-core solder. (5) Twist the leads from the antenna-coupling coil to the feed-through insulators to prevent coupling between the tuned circuits of the mixer and oscillator sections of 1C6.

First Check of Circuit

When the wiring has been completed and the set is ready to be tested, the filament rheostat should be adjusted until all of its 15 ohms resistance is in series with the filament circuit. The "A" battery is now connected to its leads, as shown in Fig. 1, and the rheostat is turned up slowly until the filaments of the four tubes glow at a dull cherry red color, which is difficult to distinguish in a bright light (the voltage can be more accurately adjusted by connecting an 0.5 D.C. voltmeter from the "A" plus to chassis and varying the rheostat until the meter reads exactly 4 volts.)

Before the "B" batteries are connected to their leads, it is advisable to make a test from each "B" plus wire to chassis in order to determine whether any "short-circuits" are in existence. A pair of headphones and a 4 1/2-volt "C" battery will be suitable for this purpose and a short-circuit will be indicated by a loud click in the phones each time the contact is made, and another when it is broken. If the wiring is correct, a loud click will be heard the first time and very weak ones or none at all on successive contacts. If all is well, the "B" batteries may be connected and the receiver is then ready for the adjustment of the R.F. and I.F. circuits.

Aligning the "I.F." Circuits

It is best to align the I.F. amplifier with the broadcast band (200-550 meter) coils in their sockets, as the signals in this region are usually much steadier than those on the higher frequency bands. Place the AVC switch in the "off" position, as it is extremely

difficult to "peak" the I.F. circuits with the AVC in action, and try to tune in a weak station of about 1,000 kc. frequency. Now with a non-metallic screw-driver, adjust the padding condenser inside the coil forms until maximum volume is obtained. Never attempt to make any adjustments when no signal is being received, and do not disturb the tuning dials or volume controls during the alignment process. Next, starting with the grid circuit of the 32 second-detector and working back toward the plate circuit of the 1C6 tube, adjust each I.F. trimmer in turn for maximum signal strength. Always "peak" each circuit before going on to the next, and it is advisable to go over all of the trimmers a second or even a third time in order to obtain an accurate alignment.

The coils covering the short-wave bands are now placed in the sockets and their padding condensers are adjusted for the greatest signal volume as were those of the broadcast band. It is interesting to (Continued on page 496)

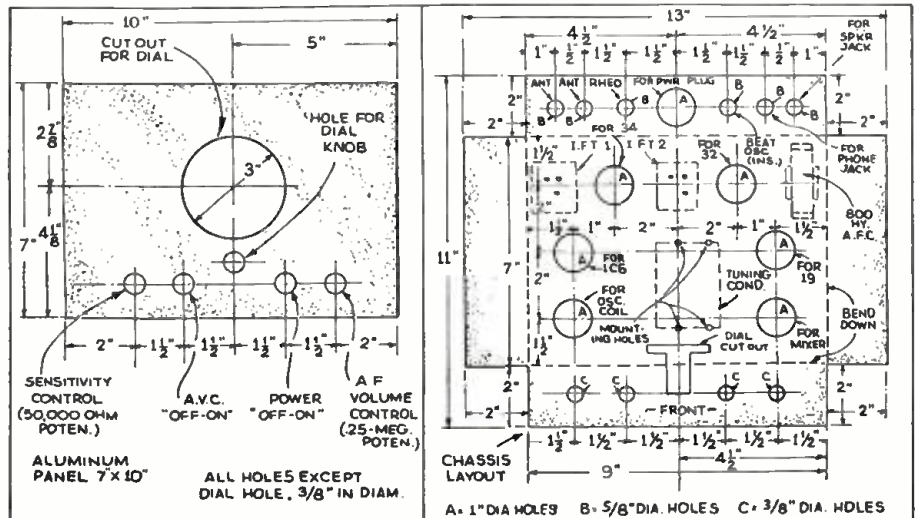

The drawings above show the dimensions for building your own chassis for the Super DX-4.

"UNIVERSAL" Receiver

Works on A.C.-D.C. or Battery

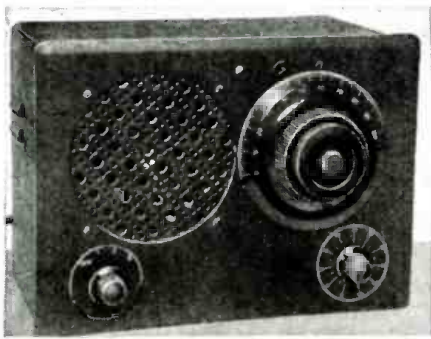

Front view of the "Universal" receiver which operates on A.C.-D.C. or 6-volt battery.

Here is a compact, well designed 4-tube receiver with 6-tube performance. It works on any A.C. or D.C. house line or on batteries—without any changes in wiring. Really two sets in one!

By Anthony C. Elgin

● YOU advocates of battery receivers—when the batteries run low and the signals get weak, don't you often wish your set could be plugged into the 110 volt house-line and end battery expense and trouble forever?

You house-current receiver fans—wouldn't you like to take your set along when you are in a car, boat, train, camp, farm—or any other place where regular current is not available?

Then this is the set for you both! It's simple to build—easy to operate—and the universal power feature is really quite inexpensive.

Circuit Simple and Reliable

The circuit is orthodox in most respects, yet the unusual results obtained warrant a close inspection of the circuit features. If you study the diagram you will note that there is an aperiodic (the dictionary defines "aperiodic" as "without cyclic vibrations." Untuned—to you) stage of Radio Frequency amplification. This is inductively coupled to the regenerative screen-grid detector.

Regeneration is maintained by electronic coupling of the grid and the plate R.F. voltage (one of the best methods) and is controllable by manual variation of the screen voltage.

Then followed three stages of audio amplification, resistance-coupled, for good quality of reproduction as well as for the sake of compactness. The audio output tube is of the power pentode type capable of handling the great volume resulting from the high-gain characteristics of the receiver.

Power for operation on A.C. is rectified by a high-vacuum

tube with low internal voltage drop. This totals six tubes, a respectable number for any small receiver packing such a "healthy wallop!"

Double-Purpose Tubes Work Wonders

Since we intend to put this to part-time "portable" use a few double tubes are needed to re- (Continued on page 494)



A peek at the rear of the "Universal" set. Plug-in coils cover all bands.

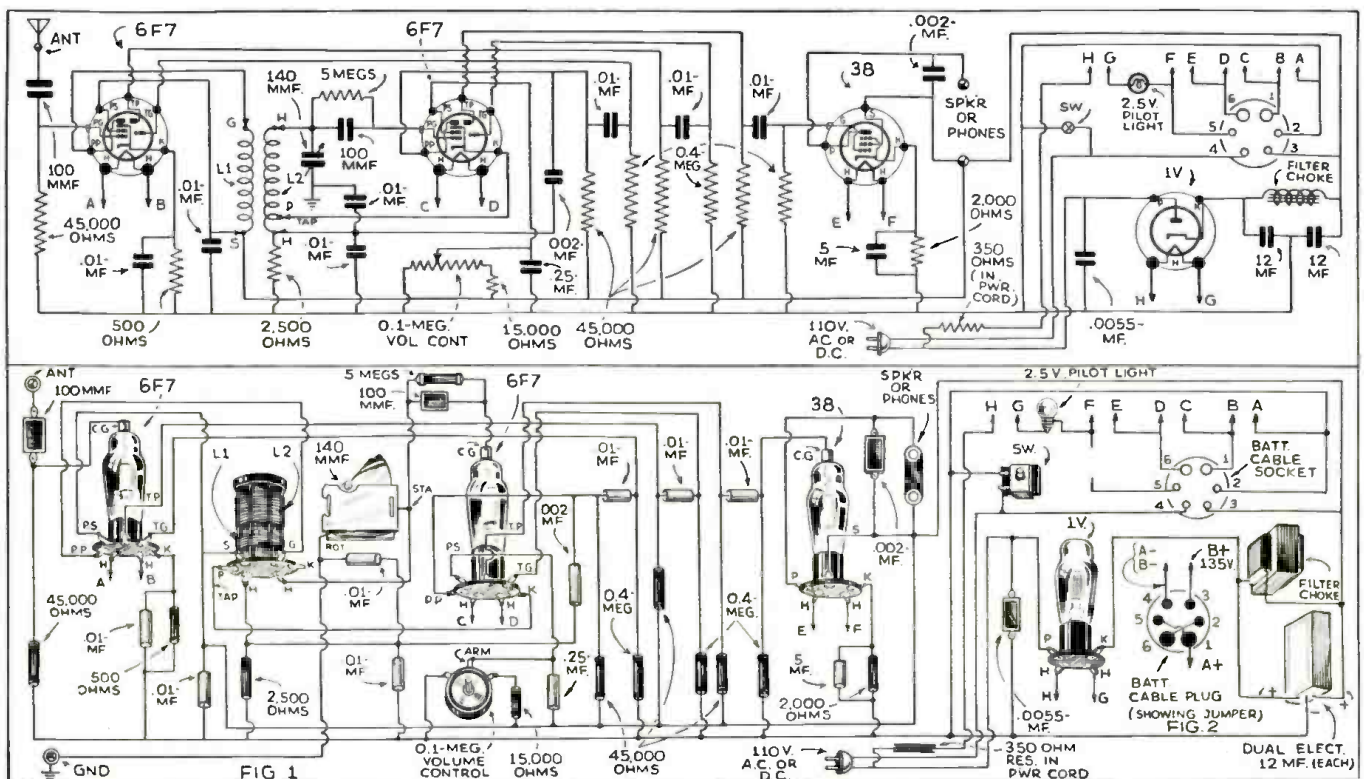

Here is the hookup of the ideal receiver for the short-wave "Fan."

**\$5.00 PRIZE
MAP LOG**

Procure a map of the United States and some small straight pins of varied colors, such as red for the "airplane" stations, green for "police" and so forth. By mounting the map on a sheet of cardboard and sticking the pins in the proper locations, you can tell at a glance by the color of the

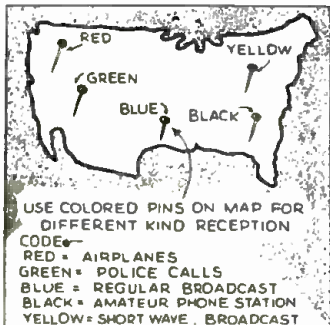

USE COLORED PINS ON MAP FOR DIFFERENT KIND RECEPTION CODE—
RED = AIRPLANES
GREEN = POLICE CALLS
BLUE = REGULAR BROADCAST
BLACK = AMATEUR PHONE STATION
YELLOW = SHORT WAVE, BROADCAST

pins if you have found a new station or if you have heard it before.—Frank Lev, Jr.

COIL SUGGESTION

Instead of drilling holes in coil forms I find it saves time and is much easier if a slot is cut in the form with a small hacksaw, as shown in the accompanying sketch. Wire ends are brought through the slot.—J. E. Bull.

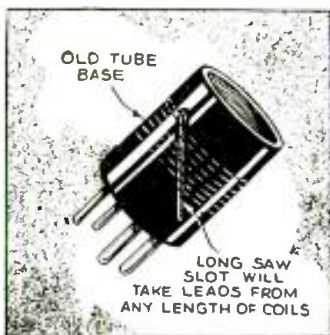

CODE KINK

Many times when learning the code, two "flams" will construct a telegraph set between their houses. Now, when it is desirable to change from the buzzer system to the "clicker" system used in regular railroad telegraphy. To do this in a hurry the circuit given is very helpful.—Warren Harding Wilson.

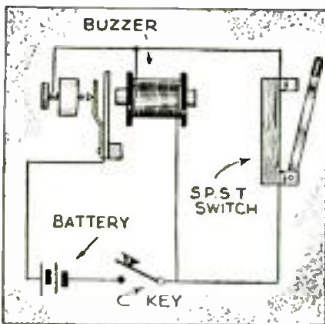

OLD TRICK STILL GOOD

I've found it convenient to use a red hot ice pick to make lead-in coil holes in old tube bases. To protect the fingers use a pick with a wood handle. The holes can be made any size desired, by the pressure applied to the pick. This is a handy method when you haven't a drill.—Dwayne McFadden.

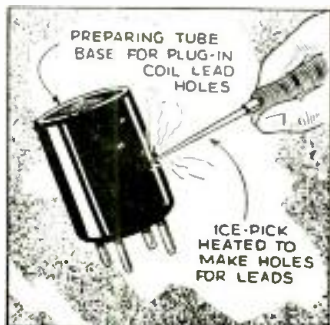

**\$5.00 FOR BEST
SHORT-WAVE KINK**

The Editor will award a five dollar prize each month for the best short-wave kink submitted by our readers. All other kinks accepted and published will be awarded eight months' subscription to SHORT WAVE CRAFT. Look over these "kinks" and they will give you some idea of what the editors are looking for. Send a typewritten or ink description, with sketch, of your favorite short-wave kink to the "Kink" Editor, SHORT WAVE CRAFT.

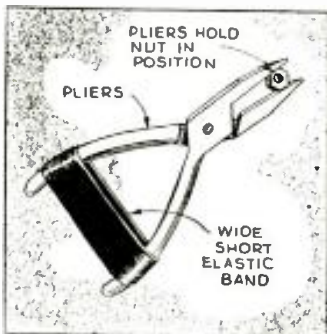

PATIENCE SAVER

This is my favorite radio "kink." Around a pair of pliers I slip a wide, short elastic band. Whenever I need something small soldered or fixed and find I need three hands for the job, I use this "kink" and save myself a great deal of trouble. When not in use, the band can be slipped down to the neck of the pliers, where it will not interfere.—George Murray.



**KINK FOR PHONE MEN
—III!**

I suppose that every one knows this one, but here it is again. A good way to get the solder from the prongs of plug-in coils is to melt the solder and quickly blow it out, as illustrated. Some of these phone men who like to gas away for hours can practice this kink with no extra strain on the old gas bag. III—Mynard Taylor, WENLI.

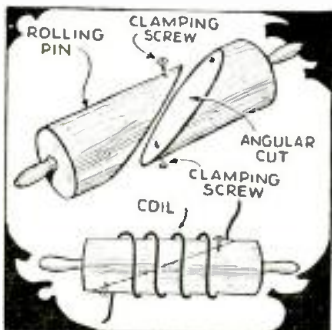

NEW USE FOR "ROLLING PIN"

I have found this coil winding kink very useful when winding transmitter or receiver coils. The coil is wound on the "rolling pin" to the desired length. The two screws are then removed and the form can be taken away from inside of the coil, without damaging the coil in any way. The "rolling pin" is cut through, as shown in the drawing, from end to end with a saw.—T. Page.

A CURE FOR "BODY CAPACITY"

This idea may not be original but nevertheless I am sure few radio "Fans" know of it. The idea is to eliminate the ca-

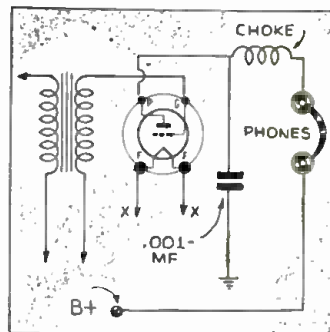

body effects from the phones present in most of the S-W sets of "home-built" variety particularly. Put an R.F. choke from the plate of the tube (in the last stage of audio) to the phones. Then place a condenser of approximately .001 MF capacity from the plate to the ground. The diagram fully explains the necessary changes.—I. Colloff.

SPOOL HOLDER

Solder wound on spools is crude to handle, unless it is set on some type of rack. The one illustrated is a very easy one to make and proves very handy. Take a piece of tubing about 9 inches long and split it down the center with a hack saw for about 4

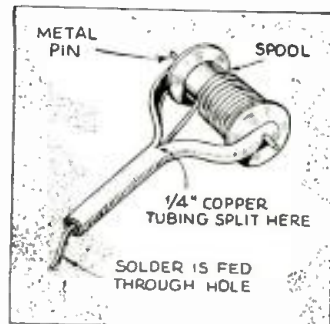

inches. Open this up and drill two small holes, one in each end. Insert the spool of solder and push a metal pin through the holes in the fork and the spool. Run the solder through the tubing and there you have a very handy solder-spool holder.—Alfred Adler.

CIGAR BOX CHASSIS AND PANEL

Here is a "kink" that should be of in-



terest to the "1 and 2-tube" "Fans" who do not like to spend money for a metal chassis every time they try a new circuit. This chassis is made from a cigar box. The lid is bent back and used as a panel.—Laimar Derk.

TESTER WITH HEAD-LIGHT

Here is a kink which I find much more useful than a regular work-bench lamp. With an old Christmas tree light-socket (small size), a thin strip of metal, a small nut and bolt, a few feet of wire, one can make a very useful test-prod light. The

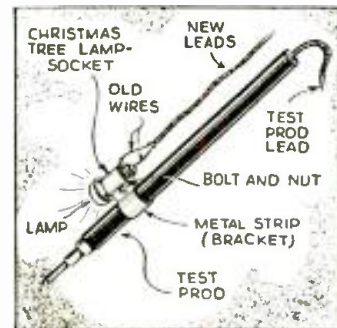
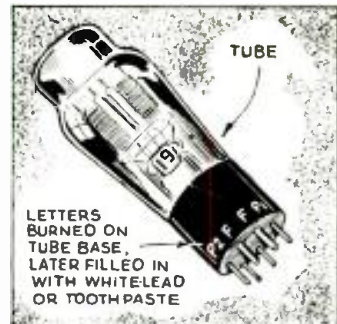

diagram shows clearly how this is done. The bulb used may be from a flashlight, with batteries as the source of current. If a brighter light is desired, a white Christmas tree bulb and a 15 volt transformer may be used.—Wm. Latta, Jr.

TIME SAVER

An ideal from marker. Many experimenters have difficulty in remembering the tube base connections. Get your set of metal alphabet and numbers and take out



these letters: "F" for filaments; "H" for heaters; "G", "I", "K", "S", "D", "1-2-3-4" for G1, D2, etc. Heat one letter, such as "F". When it is quite hot hold it above the prong you want marked, put all the impressions in their respective places, and later smooth off and fill the impressions with white lead or tooth-paste. You will find that you will have a fine, handy looking job. These markings can be put on any tubes desired except metal tubes.—Louis Supek, Jr.

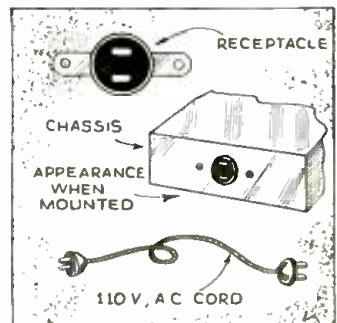

CONNECTING CORDS

Here is a kink which I am sure will be appreciated by all who build short-wave receivers. Instead of running the wires which carry the 110 volts through a hole in the side of the chassis, I enlarge the hole to fit a receptacle similar to the type used in wall outlets. Then I fit a similar cord with a male plug on both ends. In this way I eliminated the trouble of having to fix the 110 volt cord every time the insulation rubbed off. This idea also eliminates the bothersome bundle which the cord makes at the side of the set when it is tied up. These receptacles can be purchased at any hardware store for a dime.—G. N. Sacras.



A 1937 Desk Type

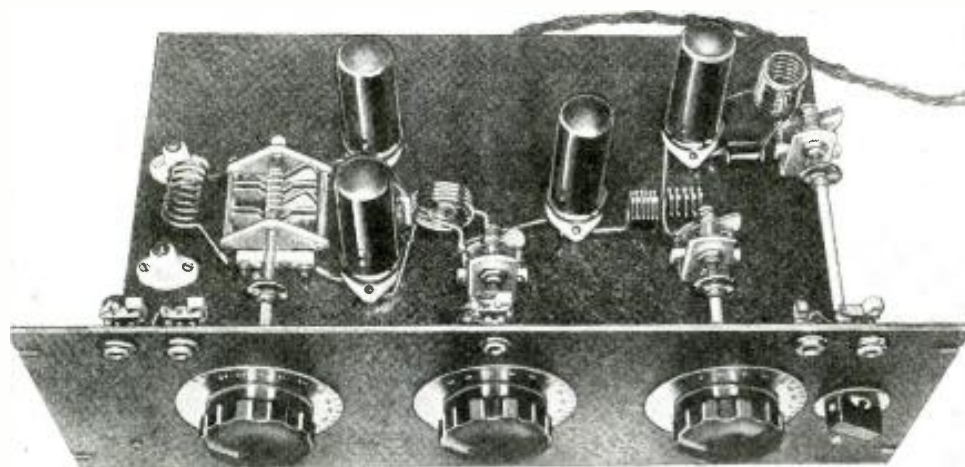

The 4-tube, 6L6 MOPA—the latest in U.H.F. design. It packs a mighty wallop!

● OUR idea of a modern *low-powered* transmitter is one that is compact in size, suitable for mounting on the operating desk; one having no less than 50 watts output and covering all bands from 80 down to 5 meters. Offhand, this would seem like a pretty large order, but considering recent developments in the trend of amateur apparatus, it is entirely possible.

The transmitter we finally decided upon, makes use of the new 6L6 tubes throughout. One unit which is a crystal controlled MOPA is used for operation on 80, 40, 20, and 10 meters. Another unit is a 5-meter MOPA, using the same tubes and mounted in the same cabinet. A common power-supply is used, while switching from the low-frequency bands to 5 meters is accomplished by merely connecting the power-supply to the particular transmitter in use by simply throwing a switch.

This complete transmitter will be described in a series of articles to appear in *Short Wave Craft*; this article describes the 5-Meter Unit.

A sketch of the proposed transmitter is shown in one of the drawings.

The 6L6 MOPA, 5-meter transmitter, described in the September, 1936 issue of *Short Wave Craft*, opened the way for simplified and inexpensive modifications of our 5-meter apparatus.

6L6 Tube Solves Problem

The 6L6 tube and its adaptability to our 5-meter "gear" has solved a problem of long standing. With this new tube, which has virtually taken the 5-meter fraternity "by storm," the amateur can build a transmitter which should certainly satisfy the most critical.

By utilizing the fundamental circuit arrangement in the original 6L6 MOPA and adding to it two 6L6 push-pull amplifiers, we have been able to produce a transmitter with better than 40 watts R.F. output and stability comparable with any crystal-controlled transmitter so far in evidence in the ultra-high frequency region. Thinking in terms of the lower amateur frequencies, 40 watts does not seem like high power; to be exact, it is classed as low power. How-

ever, in the 5-meter band, 40 watts should more than satisfy the most critical "ham." We say this because in many cases we have observed amateurs mentioning over the air that they intended to install 200, 300 watt and some 500 watt transmitters. Of course, it is every amateur's privilege to build a high powered transmitter, so long as it comes within the F.C.C. regulations, and does not exceed 1 kw. (1000 watts) input to the final amplifier. But, on the other hand, it is our firm belief that the ultra-high frequency amateurs, as a whole, would benefit if all of the transmitters were kept below 100 watts and effective receivers and antennas employed.

No Need for High Power

Despite the great amount of radio phone channels available in the 56 to 60 megacycle band, it is not going to do the situation any good to carry on "so-called" power races as we see now in evidence on the 20-meter band, for instance. So far as the experts are concerned, it is a well-known fact that *high-power* is not essential for perfect communication. For instance, if the radiated signal is gliding off the earth

some 40 or 50 miles distant, no amount of increase in power would be able to bring it down again. It is only by reflection or refraction that such an occurrence will come about. We know that DX on the 5-meter band is accomplished due to some sort of refraction or reflection, and when conditions are right all stations seem to have the same opportunity.

Frank Lester (W2AMJ) says he heard one of the boys out in the Midwestern district talking to another amateur, located in the same town, and telling him that he was about to junk his "53 unity-coupled oscillator" because he wasn't getting out! Now conditions were right and this chap was putting an R8 signal into W2AMJ's receiver! It appeared to this young man, not knowing that the band had opened up, that he wasn't getting out properly. So we ask any one, in all fairness, does there seem to be any good reason for carrying on a "power-war" in the 5-meter band? The 40 watts available from this transmitter will duplicate the results of any other transmitter under the same conditions, *even though it be four or five times greater in power output!*

Tri-Tet Circuit Employed

We start off with a 6L6 oscillator in the tri-tet circuit. The grid-cathode portion of the circuit is tuned to 10 meters and the plate circuit to 5. Tripling could easily be employed in this stage with the oscillator section tuned to 15 meters, further isolating the frequency generator portion from the modulated amplifier. From the oscillator we go into a 6L6 buffer stage. This buffer stage is an absolute necessity if perfect results are to be obtained. Our first dream, of course, was a 6L6 oscillator, driving the two 6L6 amplifiers in push-pull. In order to obtain sufficient excitation for the 6L6 amplifiers so that they could be modulated properly and efficiently, the input to the oscilla-

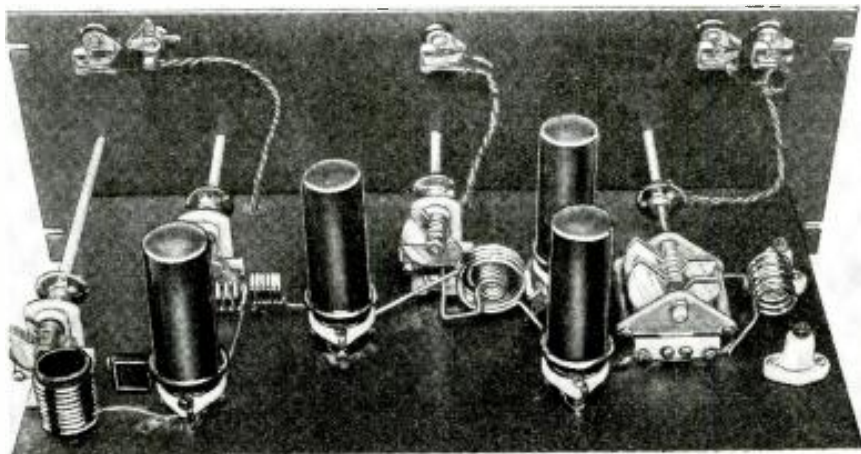

Another view showing more clearly the placement of parts.

Transmitter

By George W. Shuart
W2AMN

Part 1

This is the first of a series of articles in which Mr. Shuart will describe a modern, 1937 desk-type transmitter. The proposed design includes two separate transmitters—one for the lower frequency bands, and one for 5 meters. The 5-meter unit is described in this article, Part One, and is unquestionably the most efficient, effective and simple 5-meter transmitter ever described; it has over 40 watts output.

tor had to be in excess of that which the tube is capable of handling. Therefore, the buffer stage was incorporated. This, of course, provided more than ample excitation and permitted the use of low voltages on the plates and screens of the oscillator and buffer stages.

The 6L6 amplifier is inductively coupled to the output of the buffer stage. The photographs and diagrams clearly show that the grid coil surrounds the plate coil of the buffer. This coil is tuned with a 30 mmf. padding condenser. The adjustment here is not critical and the frequency of the transmitter can be changed within fairly wide limits, without requiring adjustment of this condenser. However, if the builder so desires, a separate tuning condenser may be used—one that duplicates the midgets used in the buffer-tank circuit and a dial control may be added to the panel.

Absolute Stability Attained

With the method of by-passing and the system of ground connections used

in this transmitter, the buffer and the push-pull amplifier operate with absolute stability.

There are no signs of regeneration or oscillator in either stage. Looking at the bottom view of the photographs and the top rear view, we find that a soldering lug is fastened underneath one screw of each tube socket, both above and below the chassis. Above the chassis the tube shield, cathode and one side of the heater terminals are all three connected to this lug on each socket. Then, turning to the underneath view of the chassis, we see a piece of No. 12 busbar (wire) connected to each one of the underneath lugs, forming a common ground busbar. Do not rely upon contact to the steel chassis through the crackle finish for such grounds. Naturally, this grounded bus is used as a "B" negative and one side of the heater system. The other connection of each of the heaters is brought through the chassis directly to a by-pass condenser, the other terminal of which is soldered to the ground busbar. Thus, we have

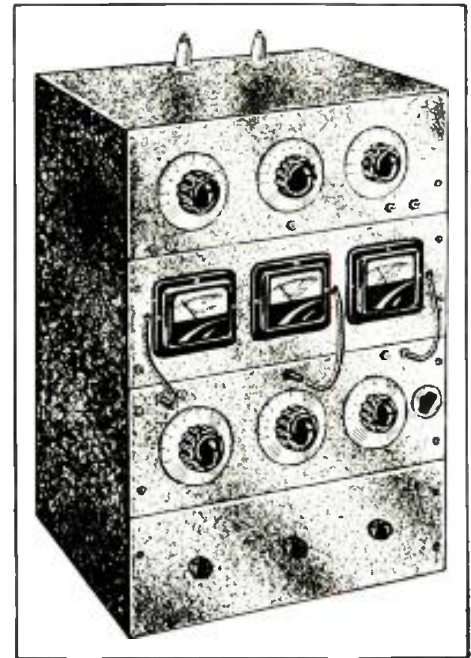

Appearance of Complete Transmitter.

one side of the heater grounded and the other side by-passed to the same point. Another (Continued on page 501)

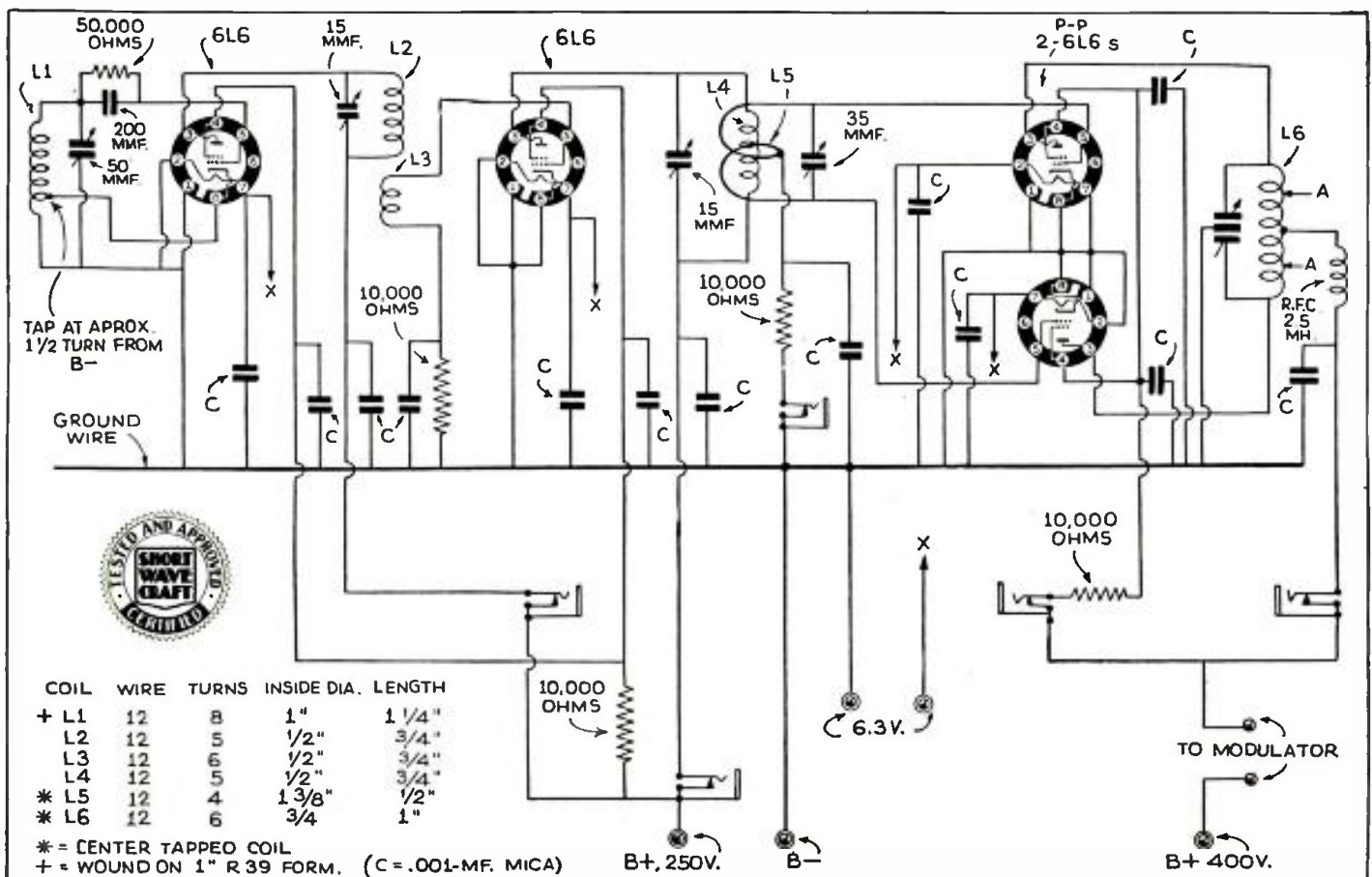

Wiring diagram, together with coil data, for the 1937 5-meter MOPA.

WORLD-WIDE SHORT-WAVE REVIEW

-Edited By C. W. PALMER

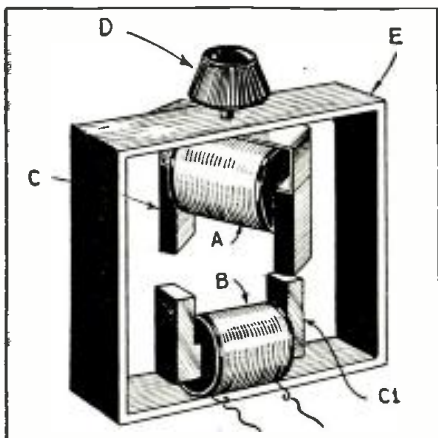

New I.F. transformer which provides variable selectivity. One section is stationary and the other rotates by means of a knob, so as to permit varying the mutual inductance between the windings.

Variable Selectivity I.F. Transformers

● THE French magazine, *La Science et La Vie* (Paris) recently described several ways in which the selectivity of radio receivers may be varied to permit high-fidelity or ordinary reception.

One of the systems described consists of the I.F. transformer shown in the sketch here. This consists of a powdered-iron core, split in two sections, on each section of which is the primary or secondary winding. One section is stationary in the metal shield; the other rotates by means of a knob or drive on the top of the shaft, shown. The mutual inductance between the two windings is thus varied, as well as the flux density of the iron core. This results in widening or contracting the band width passed by the band tuner.

Several of these transformers can be ganged together by means of a cable or flexible metal strap, so that the selectivity can be varied from the panel of the set.

A Regenerative Pre-amplifier Converter

● A recent issue of *Television and Short-Wave World* (London) contained the description of an interesting device for the short-wave fan. It is essentially a short-wave converter which is preceded by a stage of R.F. amplification. This pre-amplifier is connected as an electron-coupled oscillator, so that the gain is built up by the use of regeneration.

The converter tube is a pentagrid converter which is coupled inductively to the pre-amplifier. A trap-coil in the output of the converter circuit increases the overall selectivity of the device, when used with a broadcast or S.W. receiver.

The advantage of using the regenerative R.F. amplifier before the converter is in the tremendous gain possible by this method

which results in lower noise-level in addition to the greater sensitivity to DX stations.

The coils used in the device are the usual plug-in S.W. type, in all three circuits— arial, interstage and oscillator. The secondary of the arial coil is tapped for the cathode connection, following the usual electron-coupled circuit.

The values of the parts used in the converter-amplifier unit are indicated on the circuit, while the general layout of parts can be seen in the photo. The device has its own power supply unit, so that it does not drain current from the receiver with which it is used. A switch in the arial circuit connects the arial to the converter for S.W. reception, and at the same time turns on the current to the power unit in the converter. For broadcast reception, the switch connects the arial to the arial in the broadcast set and turns off the converter.

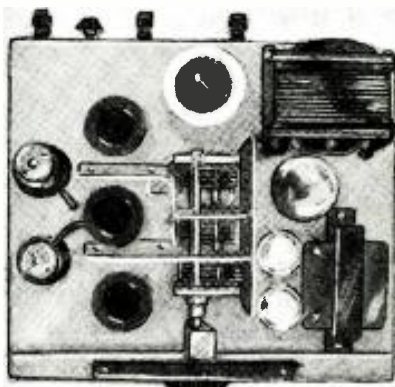

Appearance of the regenerative converter.

Novelty in Set Construction

● AN unusual method of fabricating radio receivers was described in the latest issue of *Funk* magazine (Berlin). This consists of the use of a built-up chassis, the top of which is made of strips fastened by means of screws to the side walls. These strips contain the various units which make up the complete set. For example, one strip will hold the ganged tuning condenser—another will hold the R.F. tubes and interstage coils—another will contain the transformer, chokes condensers and tube of the power-supply, etc. In this way, the complete set is made up of individual sections, each a part of the complete device. These individual units are wired independently of the entire chassis and are then inter-connected to form the final receiver, amplifier, etc.

Changes in circuit and layout of parts are thus made very simple, for, by simply

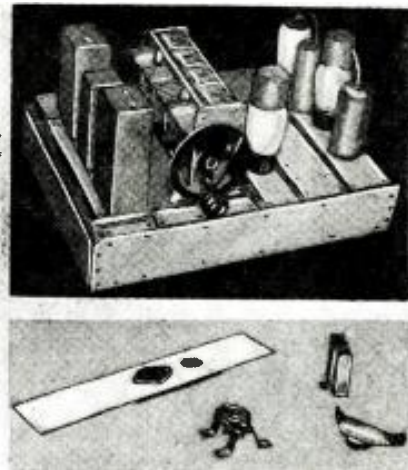

A new idea in set construction—the chassis has its top section made up of strips fastened in place by screws, thus providing greater flexibility.

unsoldering a few connections and removing a few screws, an entire section of the set—for example the tuner section, or the audio amplifier—can be taken out and another different type inserted in its place.

This system is also of interest to manufacturers, for if part of the set becomes inoperative because of the breakdown of one or two parts, the defective section can be removed in a few minutes and a new one or a re-conditioned one inserted.

Radio experimenters should find this an ideal system due to its flexibility and the ease with which different circuits may be tried.

A Pentagrid Super-Regenerator

● A SIMPLE application of the pentagrid tube to the super-regenerative principle, may not be original with the magazine from which we took it (*The Bulletin—Sydney, N.S.W. Australia*) but it is unusually interesting for those short-wave fans who play with super-regenerative circuits.

The fundamental circuit is shown in the accompanying sketch. It will be seen that all the efficiency and flexibility of the separate quenching tube is kept, without the need for two separate tubes. The pentode section of the tube is used as the regenerative tuner and detector while the triode which is ordinarily used as the oscillator (in superheterodynes) is used for the quenching oscillator circuit.

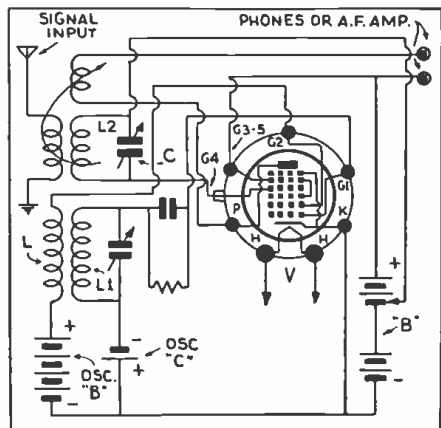

Above—circuit for pentagrid super-regenerator.

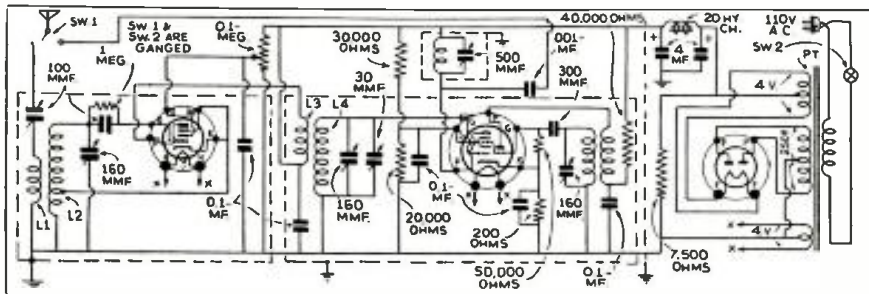

Diagram for regenerative pre-amplifier converter.

An Electron-Coupled Oscillator for 5 Meter Work

● IN the *Eddystone Ultra-Short Wave Guide*, a booklet published by a well-known English manufacturer, an interesting short wave oscillator for use on the wavelengths between 4.5 and 7.8 meters was described.

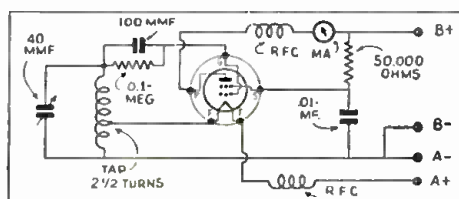

Diagram and photo above show hookup as well as appearance of electron-coupled oscillator for 5-meter work.

This type of oscillator can be used for frequency measurements using the Lecher wire method. It can also be calibrated with some accuracy by zero beating with signals on a 5 meter receiver. If stations of known accuracy can be picked up, the calibration can be made accurate within a few per cent at these frequencies and a curve made for other points within the band.

The coils for this unit, covering the frequencies between 66.7 and 38.5 MC. consists of 5 turns at a diameter of 1/2-in. and tapped at the center. The values of the other parts used in the device are indicated in the circuit and the positions of the parts are shown in the photo. The two chokes are low-inductance units designed for ultra-high frequency work and are very important in the operation of the unit, so the best available coils should be obtained.

The indicating meter is a D.C. milliammeter having a range of 0-5 milliamperes and if desired this instrument can be connected separately and terminals provided for connecting it to the oscillator. In this case, a shunt can be provided when the instrument is not being used, so that the circuit is complete. The tube may be any tetrode such as the 32, 57, 6J7, etc., depending on the type of battery supply to be used.

A V.T. Voltmeter for the Amateur

● IN THE measurement of A.C. potentials, especially in the radio frequency spectrum, the use of a V.T. voltmeter is indispensable. But, unfortunately this type

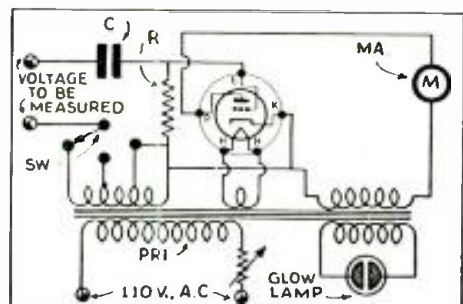

The amateur often desires to use a vacuum-tube voltmeter, and the one shown in the diagram is very simple to construct.

More World-Wide Review Diagrams

of meter requires continuous checking in order that the calibration can be depended upon. In other words, if either the filament, grid or plate voltages applied to the tube are changed—by line voltage changes or by batteries wearing out, the calibration of the meter is incorrect.

In a recent issue of *Funk Technische Monatshefte* (Berlin), a V.T. meter was described which overcame the difficulties mentioned above. It consists of a cathode-type triode tube, such as the 56, 27, etc. connected with a power transformer to the power line. Since the tube acts as a rectifier, in carrying current only between cathode and plate, though not in the reverse direction, the A.C. potential can be applied to the plate and grid circuits directly.

The grid winding is tapped so that varying values of bias can be used to supply different ranges to the instrument. An additional winding is included on the transformer supplying about 80 Volts to a neon glow lamp. The primary winding of the power resistor so that the voltage applied to the unit can be varied. Then, by adjusting this power resistor, a point can be reached at which the glow lamp just lights. Then the instrument is calibrated, in the usual way, against a standard voltmeter using a direct current or a low frequency A.C. voltage.

The glow lamp then indicates the correct working voltage and regardless of changes in line voltage, etc., the instrument can be easily adjusted for the correct working voltages. The glow lamp provides a continuous indicator of operating conditions.

No values were included for the transformer voltages, grid-leak value, etc., but the experimenter can find suitable values by experiment.

A German 10-Meter Reflex Set

● A NOVEL type of reflex receiver, designed particularly for use on the 10 meter band, appeared recently in *Funk* (Berlin) a German radio magazine.

In the design of this set, which uses two tubes, an output pentode was used. This tube combines the dual purpose of output pentode tube and a periodic H.F. amplifier. To provide this dual action, the aerial is coupled to the grid of this tube, with a split plate circuit, one branch going to the R.F. tuning circuit and the other to the speaker transformer. The signal then passes from the tuned circuit to the triode detector, which is the regenerative type, to provide the greatest possible sensitivity and also to permit CW reception. The output of the detector is coupled to the grid of the pentode through an A. F. transformer with adequate filtering to remove all traces of the R. F. signal. The signal is then amplified at audio frequencies and fed to the speaker, by the pentode.

The values of the parts used in this receiver are indicated on the circuit. The coils are the usual plug-in type designed to cover the desired frequencies (in the original set this was the 10 meter band,

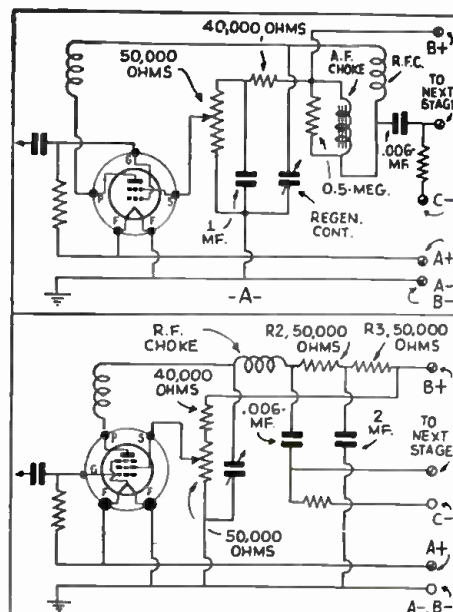

The two diagrams above show means of improving the detector in regenerative short-wave circuits.

though any short wave band can be covered with the correct size coils).

Novel Detecting Schemes

● IN A recent issue of *World-Radio* (London) several interesting circuits for improving the detector in regenerative short-wave sets were described.

It is well-known that in this type of set, the detector is the most important part. The multi-grid tubes of screen-grid and pentode types have certain advantages over the triode type, but they must be properly applied to bring out these superiorities.

The first circuit shown concerns the coupling to the A.F. amplifier. Because of the high impedance of the screen-grid tube, transformer coupling is not very suitable. Resistance coupling cuts the plate voltage down so much that excessively high voltages are necessary, and impedance amplification is inclined to be unstable.

The solution lies in a combination of the latter two methods. As shown, the plate load consists of a choke and resistance in parallel.

The second circuit makes use of an output type of pentode tube, connected with the ordinary control-grid used as screen-grid, or "priming" grid as it is called in England. The regular screen-grid is used as the control grid. The trick in getting the best out of this adaptation is to have the correct potential on the (new) screen-grid. This type of circuit will give high sensitivity according to *World-Radio*, if the correct voltages are used and sufficient decoupling is used in the output. A good method is to use resistance coupling as shown in the circuit here.

(Output pentodes oscillate very easily, but due to the comparatively large grid-plate capacity they cannot be used for wavelengths below 10 meters.—Editor.)

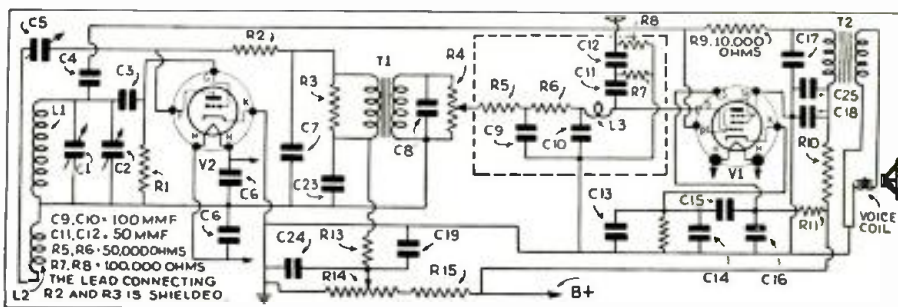

Diagram above shows German 10-meter reflex hookup which uses two tubes. The pentode serves two purposes, as becomes evident.

SHORT WAVES and Our Readers Forum. LONG RAVES

A S-W Listener in Shanghai, China, Wins Prize



This month we salute Mr. F. X. C. N. Sequeira, of Shanghai China, for the photo of his excellent short wave listening station. He wins the one year's subscription to *SHORT WAVE CRAFT*, offered each month for the best station photo.

Editor, *SHORT-WAVE CRAFT*:

On the extreme left top corner are my certificates of admission to the *Short-Wave League*, International Short-Wave Club and Chicago Short-Wave Club. Next to them are my verification cards from Europe, Australia, North and South America.

The receiver on the extreme left is an RCA ACR-175 Amateur Communications Receiver and it is mounted on a special cabinet designed by myself and made by a Chinese carpenter. There is a large baffle board in this cabinet, 24 by 18 inches, made of a board one inch thick. The resultant music when I pick up on orchestral broadcasts from Germany or Italy is simply superb.

The receiver next to my ACR-175 is an 8-tube all-wave superhet built by myself. The Console cabinet was also designed by the writer and made by a Chinese carpenter. This cabinet has a similar baffle-board 24 by 18 inches. On top of the receiver is a pre-selector or booster. With the booster in operation I can pick up difficult stations like Schenectady and Pittsburgh with comparative ease.

Next to the arm chair is a Columbia Gramophone with a special pick-up. This pick-up is connected to the 8-tube receiver.

With this combination and resting on my easy chair with a nice cigar and refreshment, my evening entertainment is ideal as I have the whole "radio world" at my fingertips.

F. X. C. N. Sequeira,
P. O. Box 562, Shanghai, China.

A Swell Canadian Listening Post

Editor, *SHORT WAVE CRAFT*:

I present you herewith photo of myself and my cozy little "short-wave corner" and hope that this picture is clear enough to appear in *Short Wave Craft*.

The receiver I am using is the Rogers model "Ten/65." With this receiver I use the "Type C.R. 4918 all-wave antenna sys-

tem, running in a north and south direction.

Herewith you will find a list of my favorite short-wave stations. P.C.J. in Holland, is one of my outstanding "catches."

In the evening I have little trouble in picking up on the short waves. I have been trying to get TFJ, Iceland, to come in clear enough to send them a letter, but up to date I have not been able to. In the near future I expect to be able to get them the same as I do my South American and Australian friends.

In conclusion may I say that I have found *Short Wave Craft* my "right-hand man" in radio work. I shall never be without this most valuable publication.

I shall be anxiously looking for my photo in the *Short Wave Craft* and do hope my photo is clear enough. I shall keep in touch with you and let you know how I am progressing with my radio work. Many thanks for all your kindness and wishing you the best of health and success. I remain,

DANIEL TRAXLER,
102 Abbott St.,
Brockville, Ontario, Can.

(Nice work, Daniel, and we hope to receive many more good photos of the "listening posts" operated by our many friends in foreign countries.—Editor)

Daniel Traxler of 102 Abbott St., Brockville, Canada, has heard short-wave stations broadcasting from many climes, as evidenced by this "sample" of his large collection of "veri." cards.



Manchester, N. H. S-W "Fan"



J. S. Picard, of Manchester, N.H., is an enthusiastic short-wave listener.

Editor, *SHORT WAVE CRAFT*:

I have been a constant reader of your splendid magazine for over two years, and I am a member of your *Short Wave League*.

I am submitting a photo of my short-wave "listening post." In the left-hand corner on the table is my 3-tube A.C. receiver using a 24 detector, 27 first audio amplifier, and a 45 power amplifier. In the center is my 5-meter receiver and a tube-tester; on the panel at the left is a power supply delivering from 22½ to 400 volts pure D.C. In the center is my 160-meter C.W. transmitter and above it a loud-speaker. As soon as I can speed up in my code I shall take a test for my "ticket."

I always find difficulty in keeping away from the newsstands when the next issue of *Short Wave Craft* is due!—J. S. Picard, 230 Lowell St., Manchester, N.H.

Howard Earp, W7CHT, Payette, Idaho, Wins Prize for "Ham" Station

Editor, SHORT WAVE CRAFT:

The transmitter for station W7CHT consists of a 59 tritet crystal oscillator, a pair of 46's in parallel, buffer or doubler, and a 211 final amplifier with 200 watts input on phone, and 300 on CW. Link coupling is used on 20 and 10 meters to the final amp., capacity coupling on the other bands. The r.f. portion and power-supplies are built in the rack and panel and the speech amplifier and modulator are built in the center cabinet on the operating table. A double-button mike couples to a 77 triode connected, a 56, pair of 45's, driving 4-46's in Class B.

The receiver is a 5 tube T.R.F. A.C. using a 58, 57, 56, 2A5 and 280. To the left of it is the ten-meter converter, which is used ahead of the receiver on that band. The receiver will soon be replaced by a home-built superhet. Directly above the converter is a neon oscilloscope, which works out very well in checking modulation, hum, distortion, etc.

A doublet with twisted wire feeders is used on each band, four antenna's being necessary, as this type will not operate on a harmonic. The 20 meter doublet is rotatable, and helps considerably in working DX. The transmitter uses plug-in coils throughout and can be shifted from one band to another in 3 or 4 minutes. Operation is mainly on 20 meter phone, and often on ten meter when the band is "open." Also operated on 40 meter CW and 74 meter phone.

Have been a member of the AARS, ARRL and ORS, and just recently qualified for

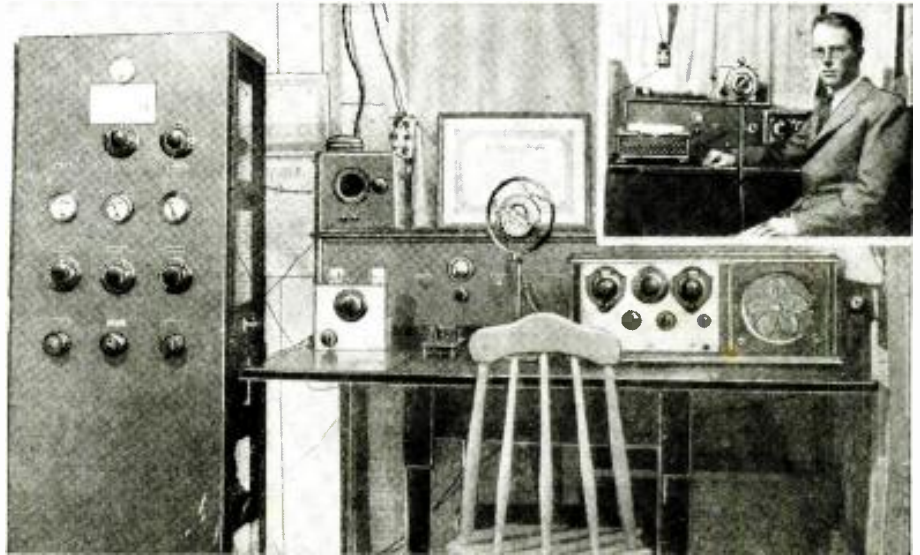

The W-I-N-N-A-II!—Howard Earp, of Payette, Idaho, takes the "cake" for Ham stations this month. Howard has a particularly neat station and one that even the editors would be proud to own.

the WAC certificate on CW. I need Africa and Europe for phone WAC. Number of countries worked are about 30.

I have found some very good articles in *Short Wave Craft* magazine, especially on receivers. My receiver is built according

to the diagram in January 1934 issue, and the new receiver will combine several diagrams in the same issue.

Very best 73 to you and all the "gang."
Howard Earp, W7CHT,
Payette, Idaho.

English "Ham"



From the land where "wireless" got its first commercial start—England—and here we see amateur station, G6ZU, owned and operated by R. H. Jackson, whose address is given with his letter.

Editor, SHORT WAVE CRAFT:

I present herewith photograph of my transmitter. My receiver is a Pfanstiehl Single-Signal superhet with a Miller pre-selector and a National SW-3 as a "stand-by." My transmitter is a crystal-controlled unit working generally on 14 and 28 m.c. approximately, with 45 watts input from "b" batteries. The final output tube is an R.K. 18, although I occasionally use an R.K. 20. I have worked all countries and am WAC (worked all continents) and WBE (worked British Empire) several times.

R. H. Jackson, G6ZU,
54 Prince's St.,
Stockport, Cheshire,
England.

XE1DD—F. L. Saldana, Mexico, a "Live" Ham

Editor, SHORT WAVE CRAFT:

I have been for years a faithful reader of your fine magazine; it is without a doubt, the best paper for S.W. "fans" and "hams." You are the only source of practical information for the experimenter.

I have been on the air since February last year with my call XE1DD. I have experimented with most every circuit within the reach of my pocket, but after thoroughly experimenting with most types of receivers and xmitters I came back to the old reliable hook-ups.

My present equipment is composed of the famous "Globe Trotter" receiver, with the simple addition of another audio stage, and the TNT Xmitter described on pages 270, 271, 272 and 311 of your September 1933 issue of *Short Wave Craft*. You may think I am a little out of date... but Oh Boy, what fine results! Here is the dope: "GT" receiver: 2nd audio stage transformer-coupled, and using another 230 with 90 volts. One .00003 m.f. variable condenser is used as band-spread, but it is seldom necessary as the main condenser (tuning) has been reduced to .000075 m.f. and I have the 20 meter band on 30 degrees. Coil for 20 mts. 6 t. grid and 3 t. tickler. With a small switch I cut out the filaments of the last audio '30 and I get a faint signal of my xmitter in the "cans" while xmitting. RESULTS: 32 countries in all six continents. Isn't that fine work! Receiver is otherwise exactly as described in your November 1932 issue.

The present Xmitter was inaugurated on the 20 meter band on March 17, and from then on these are the RESULTS: 158 QSO's. DX-All Xe's. W's, VE's, CM-2-6, YN, NY, TI-2-5-8, VP4, CE, CP, EA, ON, D-2-4, OM, VR4, VK.

And the reports run like this ob: Most W reports are QSA 5 R 9, Most VE's reports QSA 5 R 7. EA5BS, at Cartagena, Spain reported QSA5 R6 Vy fb. VK2GU, Sidney, Australia, reported QSA5 R5, fb. fb. CE3AO says "U R the best hrd stn hr." D4NVR reported from Nuernberg, Germany QSA5 R7. Miss Denis Q. Alridge reported from Greenock, Scotland QSA5 R6 "No XE stns hrd hr due to local screening." VP4TJ says "U R only XE I ever hrd hr." Mr. L. A. Schwarz from Coldwater, Mich. (an exceptionally fine type

of SW fan) "recorded on tape" my transmission while in contact with W5CPT.

The aerial is of the "end-fed" type composed of a single wire, with one side coupled to xmitter and the other hung from a pole 60 feet above the street level. The length of the wire is 120 feet.

The fact that these fine results were obtained only when I made the sets exactly as specified in your magazine speaks lots for it.

I am sorry only a few boys send cards. I QSL EVER. I will be glad to swap photos and letters.

Mr. F. L. Saldana,
Radio Amateur XE1DD,
Cia Eléctrica Mexicana S.A.
Huamantla, Tlax. Mexico.

Knock! Knock!—Who's there?—Felipe L. Saldana. And we are mighty glad to salute one of our brethren from across the Rio Grande. We are pleased to hear that you found the "Globe-Trotter" receiver, as well as one of our transmitters, so satisfactory. We hope to hear from you again with some more news.—Editor)



A short-wave voice from another country, Mexico, and a peek at the station owned and operated by F. L. Saldana, XE1DD.

One Year's Subscription to
SHORT WAVE CRAFT
FREE

for the "Best" Station Photo

Closing date for each contest—75 days preceding date of issue; Nov. 15 for Feb. issue, etc. The editors will act as judges and their opinions will be final. In the event of a tie a subscription will be given to each contestant so tying.

Fixed Condensers Made from Coils of Wire



Various small capacities or condensers can be made up by winding insulated wire on to wood dowel sticks, fibre tubes, etc. By proper arrangement of the units, the condensers can be made non-inductive

● HOW often do you get stuck for a very small capacity condenser? As often as we do, presumably. Well, here's a little idea that ought to appeal to you. Nothing less than condensers made with common D.C.C. wire, which can be wound up to make any small capacity you need.

The principle is just the same as for ordinary condensers, except that there are only two "plates." Take for example the .0001-microfarad condenser. You need 4 ft. 6 in. length of No. 22 gauge D.C.C. wire.

Put one end in the vise and stretch until it "gives." Then take the two

ends and clamp them in the jaws of a twist drill. Fix the looped end of the wire in a vise and twist away until the wire resembles a sort of flex.

It is important to do this job prop-

erly—by which we mean you must wind or twist really tightly, otherwise the capacity between the two wires will be lower than it should be owing to the gap.

When the wire has been twisted you cut the loop and spread the two ends apart so that they cannot touch. Clean the two ends that were in the jaws of the twist drill—they are the two contacts of the fixed condenser.

That, actually, is the condenser. As it is 2 ft. 3 in. long, though, it is not practicable for use in a set, and even if it were, it is inductive and liable to

(Continued on page 506)

Capacity	Wire Length	Winding Length
.0002	9 ft.	4 1/2 in.
.00015	6 ft. 9 in.	3 in.
.0001	4 ft. 6 in.	2 in.
.000075	3 ft. 1 1/2 in.	1 1/2 in.
.00005	2 ft. 3 in.	1 1/4 in.
.000025	1 ft. 1 in.	1/2 in.
.000012*	7 in.	3/8 in.

*Not non-inductive.

GRID BIAS—How and Why

By Norman C. Edwards

● CIRCUITS may come and circuits may go (they usually do) but bias goes on forever! That is, it will as long as the present type of vacuum tubes are in use. And, since *biasing methods* have become standardized, it behooves the experimenter to become familiar with the various types of bias as well as the advantages—and disadvantages—of each. A thorough knowledge of the subject should be invaluable to the individual. This is written with the intention of conveying to the reader a good working knowledge of the subject.

First, why is bias necessary? To understand this we must realize that the main purpose of bias is to limit plate current. In any tube circuit the plate is at a *positive* potential, while the cathode is *negative*. This means that a current will flow from cathode to plate and, if there is no way of controlling this current, it will become excessive and ruin the tube. It is evident, then, that there must be some means of controlling the plate current.

Vacuum tubes are constructed with a grid mounted between the cathode and plate. The grid is a spiral-shaped element and its position is such that the *electron stream* flowing from the cathode to the plate must flow through it. The action might be likened to water flowing through a screen. The grid's potential determines the amount of electrons that get by it and to the plate.

This is easy to understand when it is remembered that the electrons leaving the cathode are *negative*. Since *likes* repel, if the grid is negative, it will repel the electrons coming from the

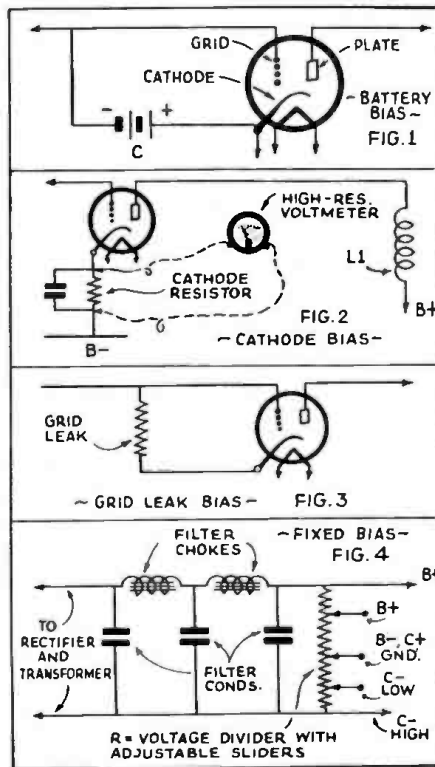

Fig. 1—The well-known battery bias. Fig. 2—Cathode resistor bias method and how drop in voltage is measured. Fig. 3—Simplest or "grid-leak" bias. Fig. 4—Illustrates "fixed bias"—here the biasing resistor is a part of the bleeder resistance.

cathode and thereby decrease the plate current. When the grid has neither a positive nor negative potential, it will offer practically no resistance to the electron flow; when it is at a high enough *negative* potential it will completely stop plate current. All the values between zero bias and *cut-off* bias have a continuously varying effect on the plate current. In this manner the grid bias controls the plate current.

Biasing Methods

There are four common methods of providing the required bias for vacuum tubes. The simplest is known as *battery bias*. (Fig. 1) In this method a battery, either wet or dry, is connected so that its *negative* terminal goes to the grid of the tube or tubes under consideration and its *positive* terminal is connected to the cathode. The result is obvious: the grid is placed at a negative potential with respect to cathode by as much as the voltage of the battery. It is necessary to select a battery whose voltage is near that required for biasing the tube in question. It is interesting to note that since there is no current required in the grid circuit, there is no drain on the battery. In cases where the voltage requirements are high, battery bias may be obtained from a separate power-pack. This is only necessary in Class "C" R.F. amplifiers and is a subject in itself.

Cathode Bias

Cathode bias is so called, because the resistor that builds up the bias is in the cathode circuit. We have found

(Continued on page 506)

WHAT'S NEW In Short-Wave Apparatus

The short-wave apparatus here shown has been carefully selected for description by the editors after a rigid investigation of its merits.

25 Watt Junior Transmitter

By Frank Lester,
W2AMJ

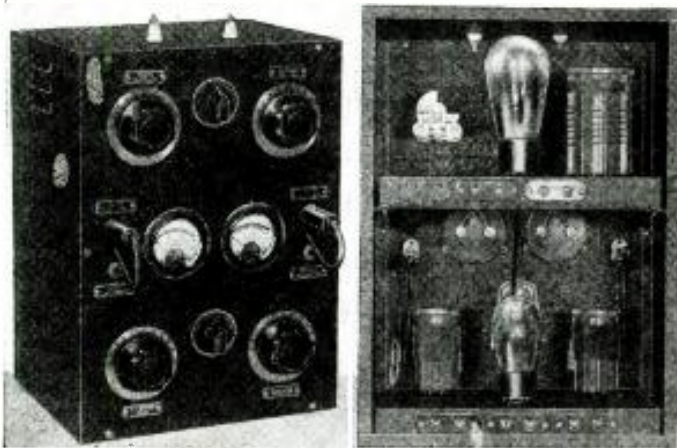

Front and rear views of 25-watt Jr. transmitter.

● THE Trutest 25 watt Junior transmitter is one of straightforward design, employing exactly the same circuit as the now-popular Lafayette P46 transmitter, which has made a great number of friends. This circuit was chosen for simplicity of construction and operation, as well as its "sure-fire" performance. The circuit consists of the Les-tet oscillator buffer or doubler, using a 56-53 tube combination instead of the 2B6 tube, which is not generally available, driving a pair of 46's in parallel as the neutralized amplifier. At all times, the 46's act as an amplifier as all doubling is accomplished in the Les-tet circuit. This oscillator buffer-doubler is the most efficient doubler we have played with; it is very easy on the crystal, even though improperly adjusted, which it is almost impossible to do.

The tubes employed are also well known for their performance and economy. In view of this, it is felt that this is the ideal "transmitter kit" for the beginner, who wants to build a small transmitter, and still have that "professional" appearance. We

feel quite sure the Trutest 25 watt Junior transmitter has all this and more, as the photographs prove.

The tuning range of this transmitter is from 160 to 20 meters, sets of coils are available for all of the amateur bands included in this range. The output power on all of these bands will be 25 watts.

At this point, it might be explained why this transmitter is rated at 25 watts and why the P46 Lafayette transmitter is rated at 30 watts. This is explained by the fact that in the manufacturer's efforts to keep the cost of this transmitter and its power-supply at a minimum, only single-spaced tuning condensers are employed throughout, while the matched power supply unit for this transmitter only supplies 400 volts. With this voltage, the power output of this transmitter is limited. The P46 transmitter employs a larger power-supply, which delivers 600 to 650 volts; this requires the double-spaced condensers and high-voltage "filter" condensers.

Because this is a small transmitter, do not get the idea from what has been said previously, that the results expected need be also small, for if you do, you are greatly mistaken. This little transmitter has a range of approximately 1000 miles on 80 meters CW, and a more or less unlimited range on 20 meters. As the

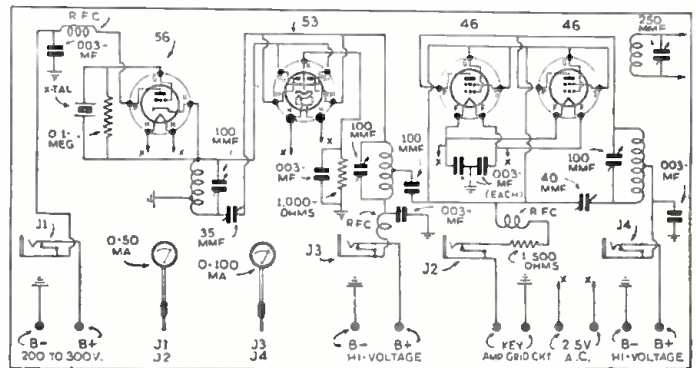
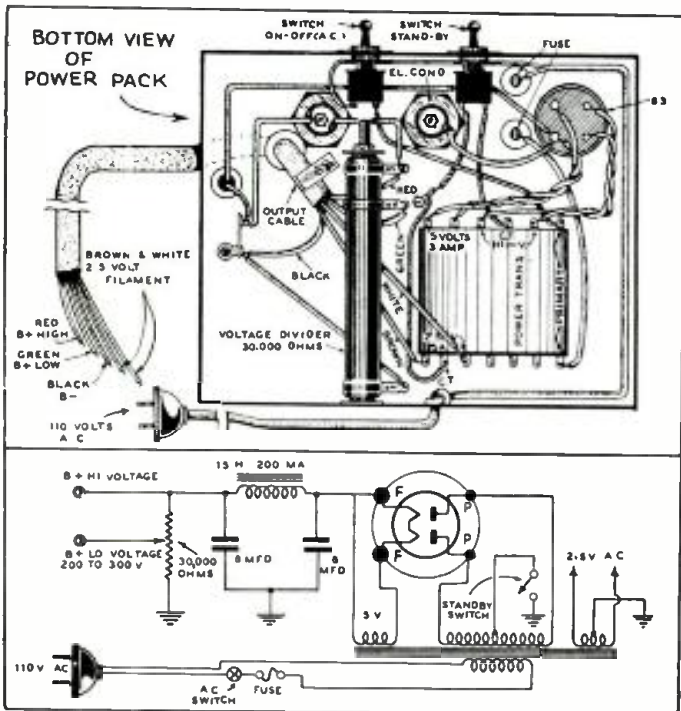

Diagram of 25-watt transmitter.



Make-up and diagram of power-supply unit for 25-watt transmitter.

range of all transmitters is, however, not alone governed by the transmitter itself, but the particular location and antenna installation, as well as the frequency, the range of any transmitter cannot accurately be given, due to these variable factors.

Testing and Operating: When the unit is completely wired and checked, the tubes, coils and crystal should be inserted, and a power supply capable of delivering 350 to 400 volts D.C. at approximately 150 milliamperes as well as 2½ volts at 6½ amperes, should be connected to the respective terminal strips. The Trutest power supply kit No. YY-21068 has been especially designed for this unit. However, as mentioned above any power supply delivering the proper voltages may be employed.

Coil Combinations

The coils to be used will depend entirely upon the choice of crystal and output frequencies. As a rule, the three stages will be tuned to the same frequency when operating on the 160, 80 and 40 meter bands. For 20 meter operation a 40 meter crystal is required, to be used with a 40 meter oscillator coil, a 20 meter doubler coil, and a 20 meter amplifier coil. It is possible, however, to obtain entirely satisfactory operation on the 80 and 40 meter bands when using 160 and 80 meter crystals, respectively, and doubling in the buffer stage. Possible combinations of coils and crystals for operation on the different bands may be seen on the chart below.

Output Band	Crystal	Osc. Coil	Buffer Coil	Amp. Coil
160M	160M	160M	160M	160M
80	160	160	80	80
80	80	80	80	80
40	80	80	40	40
40	40	40	40	40
20	40	40	20	20

An RF thermocouple meter may be inserted in one feeder to give an indication of the current there. While this is no indication of the power output, since different antennas will give different values of antenna current for the same power, it is very useful in tuning the antenna. It also (Continued on page 504)

Names and addresses of manufacturers of apparatus on this and following pages furnished upon receipt of 3-cent stamp; mention No. of article.

NEW APPARATUS FOR THE "HAM"

SOUND CELL MICROPHONE, H71



New sound-cell microphone, H71.

● THE latest in sound-cell microphone developments is represented in this new BR-26 sound-cell microphone. Spherical in shape, this new microphone is omni-directional. Similar to most other crystal microphones this one requires no polarizing voltages and requires no input transformer thus eliminating the source of inductive hum pickup. The output level of this new Brush instrument is minus 66 D.B. and represents an impedance similar to a capacity of .005 mf. Contained as an integral part of the case is a three-prong plug with proper socket for either stand or suspension mounting. Provisions are made for connecting this microphone to push-pull or single ended input stages. An ideal microphone for the amateur interested in high-quality reproduction and for the better class P.A. installations.

NEW ANTENNA, H72

● THE Windpole Aerial shown in the photograph is a recent development of Toke Deutschmann. This pole type antenna is provided with a mounting base which permits the antenna to be fastened directly to the window of a building, on a roof or even on a motor car. It is collapsible and may easily be transported for demonstration purposes as in the case of a dealer demonstrating various types of receivers

in homes, and from its construction we believe it might be well adapted to ultra-short wave amateur transmission and reception. The photograph shows the general utility of this antenna.

UNIVERSAL SOCKET ASSEMBLY, H73

● THE socket shown in the photograph is constructed of Stentite insulating material, making it suitable for high-frequency and ultra-high frequency operation. The socket proper may be removed from the metal mounting flange, thus permitting the socket to be mounted directly on the chassis by means of a spring clip, eliminating necessity of screws. Two spacers are furnished, permitting the sockets to be mounted above the chassis when the metal flange is employed.

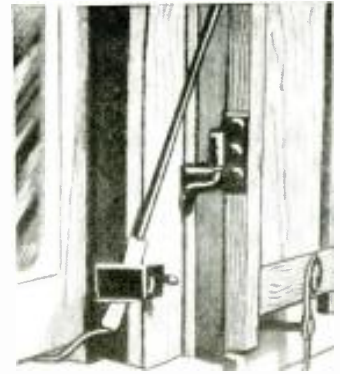

Portable antenna, H72.

NEW HIGH-FREQUENCY CONDENSERS—H74

● A new series of ultra-high frequency variable condensers, known as the HF micro condensers, has just been created by the Unit Development Division of the Hammarlund Mfg. Co. This group includes single and dual models in a variety of sizes. Both types have cadmium plated soldered brass plates with B-100 Isolantite, for insulation, to insure lowest losses, rigidity, and stability. (Continued on page 500)



Stentite socket, H73.

The BS-5 Five-Band Bandswitch Receiver

By Guy Stokely, E.E.

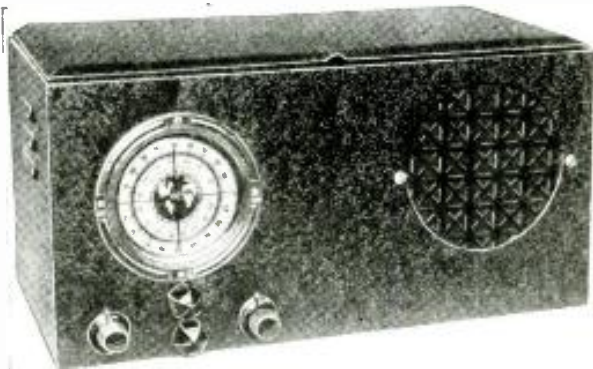

Appearance of BS-5 five-band receiver. (No. 585)

● THE Model BS-5 receiver has been designed to meet the requirements of the short wave "Fan" who wishes a sensitive and highly efficient "bandswitch" receiver. Covering the entire wavelength range of 12 to 550 meters in five bands, with no skips, this type of set does away with the necessity of continually changing plug-in coils each time the listener wishes to receive on a different band.

Operating from the 105 to 130 volt A.C. or D.C. house lighting system and containing a hi-fidelity dynamic loudspeaker as well as an automatic headphone jack, this unit is completely self-contained and very compact. The usual bothersome antenna trimmer adjustment has been successfully eliminated in its design. The regeneration and band-spread controls are extremely smooth in operation and any beginner can readily obtain excellent results from it.

Examination of the accompanying circuit diagram reveals the use of the latest in hi-gain type vacuum tubes, i.e., 6D6-6D6-76, 43-25Z5 functioning as an aperiodic R.F. amplifier, electron-coupled screen-grid regenerative detector, powerful two-stage audio-frequency amplifier with pentode output stage, rectifier and completely built-in power supply. The K42A is a line voltage dropping tube.

Signals are fed into the control grid of the first 6D6 tube and given a considerable increase in strength due to the high amplification properties of this tube. Bias for this stage is furnished by the resistor-capacity combination R2-C2, the suppressor-grid being tied to the cathode. The output of the R.F. stage is electro-magnetically coupled into the grid winding of the detector stage, the proper windings for the wave band in question being selected by means of the band-switch S1. This switch is one having an extremely low distributed-capacity and a very low leakage, in order to reduce losses to an absolute minimum. Electron

coupling is used in the detector circuit because of its high order of sensitivity, selectivity, and smooth operation. The cathode taps on the five coils have been carefully worked out in order to insure maximum sensitivity and ease of control.

Regeneration is controlled by means of the potentiometer R10 (100,000 ohms) having a specially tapered resistance characteristic. This method of oscillation control has practically no effect on the tuning adjustments. The audio frequency component of the output of the detector stage is fed into the two stage audio frequency amplifier. Resistance capacity coupling is used in order to insure the highest quality of reproduction. The output of the amplifier is ample to work the dynamic loud-speaker to full capacity on all moderate signals.

The filaments of all tubes are connected in series and lighted directly from the house-lighting system, the voltage being reduced to the proper value by means of the series tube K42A. Rectification is accomplished by the 25Z5 tube and the current is filtered by the choke capacity combination L1-C10, having a total of 30 henries and 60 mf. This is ample to remove the last trace of A.C. hum. Field excitation for the dynamic loud-speaker is obtained from the input side of the filter system.

The approximate wavelength coverages of each of the five steps are as follows: 12 to 26, 25 to 50, 48 to 90, 88 to 204, 202 to 550 meters. Operated from any aerial having an overall length of from 20 to 90 feet, this receiver is capable of consistent foreign as well as domestic reception at full loud-speaker strength.

This model is also available for use with metal tubes, and in a communications type for amateur reception.

This article has been prepared from data supplied by courtesy of Eilen Radio Laboratories.

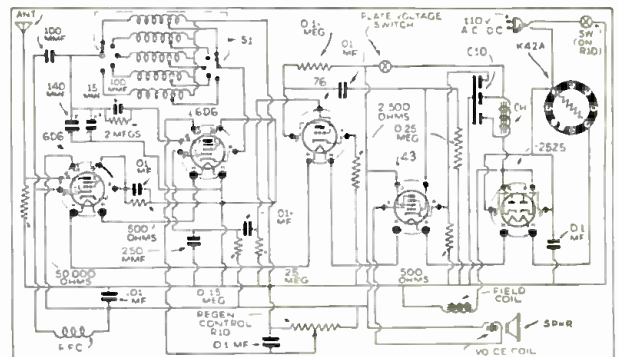

Diagram of the BS-5 receiver.

Names and addresses of manufacturers of sets described on this and following pages furnished upon receipt of postcard request; mention No. of article.

THE RADIO AMATEUR

Conducted by Geo. W. Stuart

Relays Simplify Operation of Station

● UNQUESTIONABLY the up-to-date amateur station should be relay operated. The use of relays in connection with radio and electrical apparatus not only provides a very desirable convenience but in many cases safeguards the apparatus and the operator against damage or injury. In this article we will endeavor to illustrate a number of uses to which relays might be well employed.

The first application of a relay in an amateur station is for keying the trans-

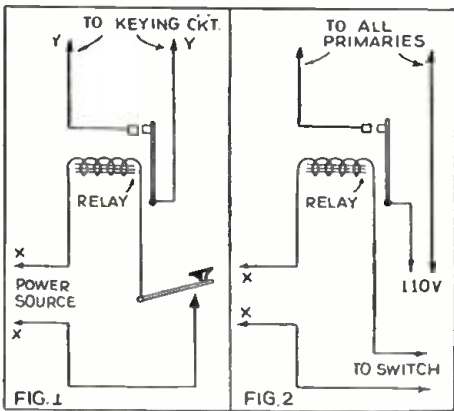

Fig. 1—Keying relay. Fig. 2—Simple circuit for turning transmitter "on" and "off."

mitter. There are a number of reasons why this works out most effectively, and they are: It removes high voltage from the metal parts of the key and permits uniform characters to be transmitted, especially when a "bug" is employed. The connections for this relay are shown in Fig. 1. The next application is for turning the transmitter on and off. In cases of low power, where filaments and plate voltages may be applied to the rectifier at the same time in the power supply, only one relay is required, as shown in Fig. 2. When using this particular method, it is advisable to have a switch in the B negative or B plus supply of the transmitter power supply, so that the plate voltage will not be applied to the tubes before the filaments are thoroughly heated.

By employing the system shown in Fig. 3 in conjunction with Fig. 2, we have a very satisfactory arrangement. This should be used as we said before where a low voltage power supply is employed so that there is no danger of damaging the rectifier tubes. The circuit in Fig. 3 primarily opens the B negative circuit right at the power transformer secondary. In addition, we have shown how the receiver may be operated in conjunction with this arrangement to permit stand-by for rapid change-over during communication. Two relays are employed here—one to disconnect the B minus center tap of

The Editors would appreciate receiving photographs, together with diagrams and descriptive matter of modern amateur stations. Those believed most suitable will be described occasionally on this page. Include as much data as you believe will provide material for an intelligent description.

the high-voltage secondary, thus turning off the power to all stages in the transmitter, and another relay to turn the receiver on by connecting the center tap in the high voltage secondary of the receiver power transformer; this is for standing-by. In order to transmit, merely make contact with the stand-by switch; this turns the high voltage on to all tubes in the transmitter and at the same time turns the receiver off.

Where higher power is used it is necessary to heat the filaments for a period of at least 15 or 20 seconds and in some cases a few minutes before plate voltage is applied. This may be accomplished with time-delay relays or more simply and more economically by the system shown in Fig. 4. Here a single double-pole, single-throw relay is used to turn on the filament transformers. The other pair of contacts on this relay complete the circuit for the high-voltage relay. Thus, when the plate switch makes contact the primaries of the high-voltage transformers are thrown on and we are ready for

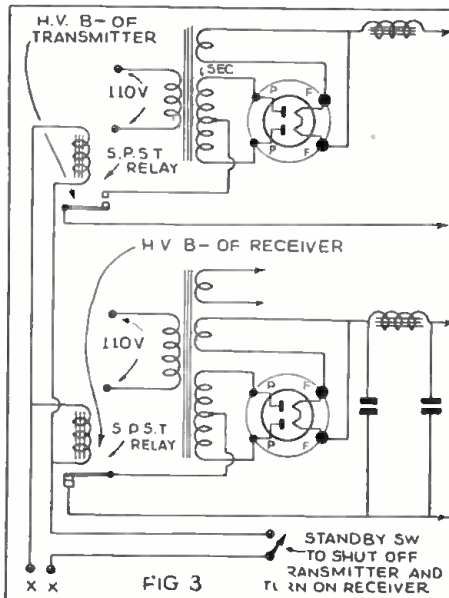

Fig. 3—This system provides rapid change-over from transmit to receive and speeds up operation.

operation. If the plate switch is pulled open, only the filaments remain on; while if the filament switch is pulled open while the plate switch is closed, they all go off at the same time, which is a reasonable measure of safety. The

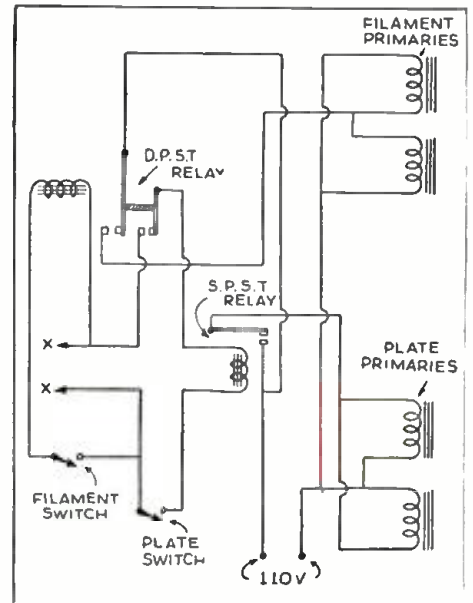

Fig. 4—How two relays are employed in a high-voltage power-supply, using separate transformers for plates and filaments.

only danger is in throwing the filament switch on when the plate switch is already closed. The operator should make sure that *this is never done!*

The entire group shown in the four different diagrams represent a complete installation. A combination for relatively high voltage would be Fig. 1 for keying, Fig. 3 for stand-by and Fig. 4 for starting the station. In the case of Fig. 4 for relatively high voltage power supplies, where separate filament and plate transformers are employed, break-in can be accomplished with the plate switch, merely by disconnecting the high voltage primary. In this case, the field of the relay operating the receiver would be connected in parallel with the field of the plate relay. Of course, if a number of separate power supplies are employed, then the number of relays will have to be increased. This will depend upon the particular station layout. If relays are installed, there is no doubt that they will prove the most valuable accessory the operator ever employed.

What Do YOU Want?
Here's your chance—Tell the Editors what subjects you would like discussed in this Department—A postcard will do—But send it! Hi!



Eddie Schmeichel, Chicago, Ill., another SWC "Trophy" winner, and one of our very finest DXers! He rates "tops" in the mid-west.

LET'S "Listen In"

With *Joe Miller*

Our Short-Wave "DX" Editor

Winner of Thirtieth "S.W. Scout" Trophy.

This is the second article by Mr. Miller. We shall be glad to have our readers send us suggestions, as well as data on new stations not mentioned here. Queries should be accompanied by a 3 cent stamp.

● WELCOME again to these DX pages, our dial-twisting friends!

The "real" DX season is now being ushered in, with steady cool weather, static dying out on the lower frequencies, and we again look forward with high hopes and assurances to this winter being one of the best DX seasons yet encountered!

Steady improvements in the art of short-wave broadcasting by the leading nations of the world has focused attention on this highly effective method of international propaganda, and many smaller nations have considered the importance of "SWs" sufficiently to put their "dot" on the map of new lands to be heard by the interested DXer.

Coupled with this fact, in increased enjoyment of short-wave reception, is the important factor of constantly improving transmitting equipment and increasing knowledge of SW transmission peculiarities, applied to the improvement of reception of each station throughout the world.

Considering all of these factors, our hopes for better and more enjoyable DXing this fall and coming Winter seem to be well founded.

We now begin last month's (Sept.) DX reception report, and we would advise that you keep our article beside you, when tuning, as constant reminders of the DX stations to be heard at various times.

The main reason for this article, OMs, is to show you *when, where, and how* to tune, in order that you yourself will not fail to also hear these nice "catches." So, go to it, you DX fiends, and may all the DX gods be with you!!

Italian Somaliland Is On The Air!

Taking the tip from our own article

ITK, not once, but easily 4 or 5 times!

ITK was heard as early as 5:50 a.m., and as late as 8:30 a.m., mornings, and also heard in afternoon at 3 p.m.

ITK's signal ranges from R6-R8, and a notable aid in snaring this rare catch is the "swing" of the carrier, which shifts back and forth quite rapidly, as in other distant African signals heard here. Try for ITK *now*, as this station seems to be on very often of late, and is easily heard. Here's a tip: there's a very powerful CW sig on every a.m., just a bit to the high frequency side of

ITK, so, upon tuning in the CW sig, you need only mark that spot on the dial, and tune dly (daily), a.m.'s, best bet 5:30 - 6:30 a.m., just to HF side of the CW signal! Here's our best wishes that you snare this real DX!! Russ Ballard, our traveling DXer, located on the Grace Line "Santa Rosa," reported reception of ITK several months ago when nothing was known concerning this catch. So, to the best of our knowledge, Russ is one of the very first to hear this "African Ace." Our sincere congrats, OM!

Addis Ababa Again Heard!

IUC, 11.955 mc, the Italian Station at Addis Ababa, is being heard with a fine signal, on the average, from as early as 11:30 p.m. to 2 a.m., quite often of late phoning Rome. A man and woman alternate at the "mike," and a sure recognition of this catch is assured by the phrase "pronto Roma" frequently injected into the conversation.

Try for this station nightly, at the extreme LF end of the 25 meter "broadcast" band, and we're sure you'll reward our faith in ur ability to add this Italian Colony

station to ur FB log books! Here's a chance for all those disappointed listeners who waited for ETB's *veri* in vain, to get 'em verified, tho under new management, hi!

Reports for both ITK and IUC should be addressed to the Rome address given in last issue % Minister of Marine.

China Makes Its Bid!

During the last month, Chinese phone stations have been unusually active. XGM, Shanghai, on 17.6 mc, has been heard several mornings, phoning the Rugby Station, GBA on 18:59 mc, and putting in a very fine signal. This station somehow favors Wed. and Fri. for operation, so our tip on XGM is: try

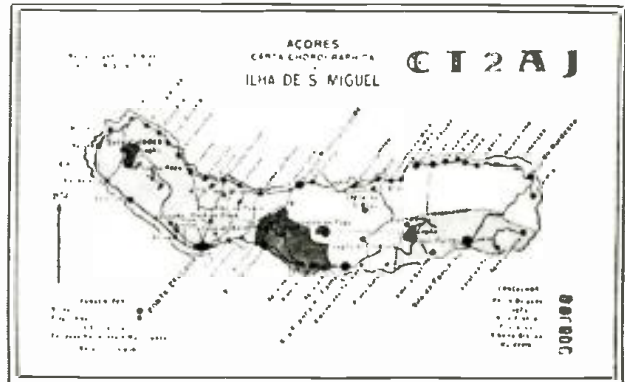

CT2AJ—A handsome multi-colored QSL from the Azores—another "mid-winter" catch.

dly, especially Wed. & Fri., from 6-7 a.m. XGM favored 6:20 a.m. several days.

Trying for XGM, our tip is to tune for GBA first, a vy powerful sig. GBA will call "Hello Shanghai," and then you need merely tune to XGM's frequency and "log" them phoning!

Two other Chinese phones have been active, tho call letters are not known. These are, Shanghai on 9.285 mc, and Hangkow, on 9.08 mc. Heard early in Sept., on several occasions, these two DX fones "worked" one another at 5:00-5:45 a.m. The Hangkow signal is louder, and both "sigs" have the usual Asiatic rapid "flutter." Distorted high voices are the general fare of these stations. Shanghai rates R4, Hangkow R 5-6, on the average.

Then there is our old reliable XOJ, on 15.795 mc, still very active between 8-12 p.m., usually most active from 8-10 p.m. This station, as given in last issue, phones JVD, and occasionally, JVF. Not very strong, so we advise very slow, (Continued on page 508)

"Greetings from the Land of Static"

To RADIO 44-842 ur CW hr at ...00 OSA R T
Fone wkd

ORH - ORM - ORN - OSB OSX - WX
the very name of India

Transmitter

Circuit 25.5 FH

Freq. 3.5 MC

Aerial 7.5 FT

Receiver

Circuit 24.1 MC

Aerial 10 FT

DX 10 FT

VU²FY

TXN FOR 0009. SALAAMS ES 73.

ORA—COROMANDEL P.O., S. INDIA. C. S. P. de 004. *Amplitude*

TXN QSL DIRECT Own-Op MEM INC. R.S.G.

VU7FY—QSL from So. India verifying 10 watt fone reception!



World S-W Station List

Complete List of Broadcast, and Telephone Stations

All the stations in this list use telephone transmission of some kind. Note: Stations marked with a star ★ are the most active and easily heard stations and transmit at fairly regular times. Please write to us about any new sta-

tions or other important data that you learn through announcements over the air or correspondence with the stations.

Stations are classified as follows: C—Commercial phone. B—Broadcast service. X—Experimental transmissions.

Around-the-Clock Listening Guide

It is a good idea to follow a general schedule as far as wavelength in relation to the time of the day is concerned. The observance of these simple rules will save time. From daybreak till 9 p.m. and particularly

during bright daylight, listen between 13 and 19 meters (21510 to 15800 kc.)

To the east of the listener, from about 4 p.m.-5 a.m., the 19-35 meter will be found very productive. To the west of the listener this same

band is generally found best from about 12 m. until 7 a.m. (After dark, results above 35 meters are usually much better than during daylight.) These general rules hold for any location in the Northern Hemisphere.

Short-Wave Broadcasting, Experimental and Commercial Radiophone Stations

NOTE: To convert kc. to megacycles (mc.) shift decimal point 3 places to left: Thus, read 21540 kc. as 21.540 mc.

<p>31600 kc. W2XDU -BX- 9.494 meters ATLANTIC BROADCASTING CO. 485 MADISON AVE., N.Y.C. Relays WABC daily 5-10 p.m., Sat., Sun. 12:30-5, 6-9 p.m.</p>	<p>20040 kc. OPL -C- 14.97 meters LEOPOLDVILLE, BELGIAN CONGO Works with ORG in morning</p>	<p>18680 kc. OCI -C- 16.06 meters LIMA, PERU Works various S.A. stations daytime</p>	<p>17760 kc. DJE -B- 16.89 meters BROADCASTING HOUSE BERLIN, GERMANY 12:05-5:15; 5:55-11 a.m.</p>	<p>15660 kc. JVE -C- 19.16 meters NAZAKI, JAPAN Phones JAXA 3-5 a.m.</p>
<p>31600 kc. W4XCA -BX- 9.494 meters MEMPHIS, TENN. Relays WMC daily</p>	<p>20020 kc. DHO -C- 14.99 meters NAUEN, GERMANY Works S. America, mornings</p>	<p>18620 kc. GAU -C- 16.11 meters RUGBY, ENGLAND Calls N. Y., daytime</p>	<p>17760 kc. IAC -C- 16.89 meters PISA, ITALY Calls ships, 6:30-7:30 a. m.</p>	<p>15620 kc. JVF -C- 19.2 meters NAZAKI, JAPAN Phones U.S., 5 a.m. & 4 p.m.</p>
<p>31600 kc. W8XAI -BX- 9.494 meters STROMBERG CARLSON CO. ROCHESTER, N.Y. Relays WHAM daily 7:30 a.m.-12.05 a.m.</p>	<p>19900 kc. LSG -C- 15.08 meters MONTE GRANDE, ARGENTINA Tests Irregularly, daytime</p>	<p>18345 kc. FZS -C- 16.35 meters SAIGON, INDO-CHINA Phones Paris, early morning</p>	<p>17741 kc. HSP -C- 16.91 meters BANGKOK, SIAM Works Germany 4-7 a.m.</p>	<p>15460 kc. KKR -C- 19.4 meters RCA COMMUNICATIONS, BOLINAS, CAL. Tests Irregularly</p>
<p>31600 kc. W8XWJ -BX- 9.494 meters PENOBSCOT TOWER DETROIT, MICH. Daily 6 a.m.-12:30 a.m. Sun. 8 a.m.-12 M.</p>	<p>19820 kc. WKN -C- 15.14 meters LAWRENCEVILLE, N. J. Calls England, daytime</p>	<p>18340 kc. WLA -C- 16.36 meters LAWRENCEVILLE, N. J. Calls England, daytime</p>	<p>17650 kc. XGM -C- 17 meters SHANGHAI, CHINA Works London 7-9 a.m.</p>	<p>15415 kc. KWO -C- 19.46 meters DIXON, CAL. Phones Hawaii 2-7 p.m.</p>
<p>21540 kc. W8XK -B- 13.93 meters WESTINGHOUSE ELECTRIC PITTSBURGH, PA. 7-9 a.m.; relays KDKA</p>	<p>19680 kc. CEC -C- 15.24 meters SANTIAGO, CHILE Works Buenos Aires and Colombia daytime</p>	<p>18310 kc. GAS -C- 16.38 meters RUGBY, ENGLAND Calls N. Y., daytime</p>	<p>17520 kc. DFB -C- 17.12 meters NAUEN, GERMANY Works S. America near 9:15 a.m.</p>	<p>15370 kc. ★HAS3 -B- 19.52 meters BUDAPEST, HUNGARY Broadcasts Sundays, 9-10 a.m.</p>
<p>21530 kc. GSJ -B- 13.93 meters DAVENTRY B.B.C., BROADCASTING HOUSE, LONDON, ENGLAND</p>	<p>19650 kc. LSN5 -C- 15.27 meters HURLINGHAM, ARGENTINA Calls Europe, daytime</p>	<p>18299 kc. YVR -C- 16.39 meters MARACAY, VENEZUELA Works Germany, mornings</p>	<p>17510 kc. VWY2 -C- 17.13 meters KIRKEE, INDIA Works Rugby 2-7 a.m.</p>	<p>15360 kc. DZG -X-C- 19.53 meters REICHSPRESENSTRALAMT, ZEESN, GERMANY Tests Irregularly</p>
<p>21520 kc. W2XE -B- 13.94 meters ATLANTIC BROADCASTING CORP. 485 Madison Ave., N.Y.C. Relays WABC 7:30 a.m.-1 p.m.</p>	<p>19600 kc. LSF -C- 15.31 meters MONTE GRANDE, ARGENTINA Tests Irregularly, daytime</p>	<p>18250 kc. FTO -C- 16.43 meters ST. ASSISE, FRANCE Calls S. America, daytime</p>	<p>17310 kc. W3XL -X- 17.33 meters NATIONAL BROAD. CO. BOUND BROOK, N. J. Tests Irregularly</p>	<p>15355 kc. KWU -C- 19.53 meters DIXON, CAL. Phones Pacific Isles and Japan</p>
<p>21470 kc. ★GSH 13.97 meters DAVENTRY B.B.C., BROADCASTING HOUSE, LONDON, ENGLAND 6-8:45 a.m., 9 a.m.-12 n.</p>	<p>19480 kc. GAD -C- 15.4 meters RUGBY, ENGLAND Works with Kenya, Africa, early morning</p>	<p>18200 kc. GAW -C- 16.48 meters RUGBY, ENGLAND Calls N. Y., daytime</p>	<p>17120 kc. WOO -C- 17.52 meters A. T. & T. CO., OCEAN GATE, N. J. Calls ships</p>	<p>15340 kc. ★DJR -B- 19.56 meters BROADCASTING HOUSE, BERLIN, GERMANY 8-9 a.m.</p>
<p>21420 kc. WKK -C- 14.01 meters AMER. TEL. & TEL. CO., LAWRENCEVILLE, N. J. Calls S. America 8 a.m.-4 p.m.</p>	<p>19355 kc. FTM -C- 15.50 meters ST. ASSISE, FRANCE Calls Argentine, mornings</p>	<p>18135 kc. PMC -C- 16.34 meters BANDENG, JAVA Phones Holland, early a. m.</p>	<p>17080 kc. GBC -C- 17.56 meters RUGBY, ENGLAND Calls Ships</p>	<p>15330kc. ★W2XAD -B- 19.58 meters GENERAL ELECTRIC CO. SCHENECTADY, N. Y. Relays WGY 10 a.m.-4:30 p.m.</p>
<p>21080 kc. PSA -C- 14.23 meters RIO DE JANEIRO, BRAZIL Works WKK Daytime</p>	<p>19345 kc. PMA -B-C- 15.51 meters BANDENG, JAVA Calls Holland early a.m. Broadcasts Tues., Thur., Sat., 10:00-10:30 a.m. Irregular</p>	<p>18115 kc. LSY3 -C- 16.56 meters MONTE GRANDE, ARGENTINA Tests Irregularly</p>	<p>16270 kc. WLK -C- 18.44 meters LAWRENCEVILLE, N. J. Phones Arg., Braz., Peru, daytime</p>	<p>15310 kc. GSP -B- 19.6 meters DAVENTRY B.B.C., BROADCASTING HOUSE, LONDON, ENGLAND Irregular, 6-8 p.m.</p>
<p>21060 kc. WKA -C- 14.25 meters LAWRENCEVILLE, N. J. Calls England noon</p>	<p>19260 kc. PPU -C- 15.58 meters RIO DE JANEIRO, BRAZIL Works with France mornings</p>	<p>18040 kc. GAB -C- 16.63 meters RUGBY, ENGLAND Calls Canada, morn. and early aftn.</p>	<p>16270 kc. WOG -C- 18.44 meters OCEAN GATE, N. J. Calls England, morning and early afternoon</p>	<p>15290 kc. LRU -B- 19.62 meters "EL MUNDO" BUENOS AIRES, ARGEN-TINA, S. A. Daily 7 a.m.-3:45 p.m.</p>
<p>21020 kc. LSN6 -C- 14.27 meters HURLINGHAM, ARG. Calls N. Y. C. 8 a. m.-5 p. m.</p>	<p>19220 kc. WKF -C- 15.60 meters LAWRENCEVILLE, N. J. Calls England, daytime</p>	<p>17810 kc. PCV -C- 16.84 meters KOOTWIJK, HOLLAND Calls Java, 6-9 a. m.</p>	<p>16233 kc. FZR3 -C- 18.48 meters SAIGON, INDO-CHINA Calls Paris and Pacific Isles</p>	<p>15280 kc. ★DJQ -B- 19.63 meters BROADCASTING HOUSE, BERLIN, GERMANY 6-8, 8:15-11 a.m. 4:50-10:45 p.m. Sundays 11:40 a.m.-12:20 p.m.</p>
<p>20860 kc. EHY-EDM -C- 14.38 meters MADRID, SPAIN Works S. America, mornings.</p>	<p>19200 kc. ORG -C- 15.62 meters RUYSELEDE, BELGIUM Works with OPL mornings</p>	<p>17790 kc. GSG -B- 16.86 meters DAVENTRY, B.B.C., BROADCASTING HOUSE, LONDON, ENGLAND</p>	<p>15880 kc. FTK -C- 18.90 meters ST. ASSISE, FRANCE Phones Saigon, morning</p>	<p>15270 kc. ★W2XE -B- 19.65 meters ATLANTIC BROADCASTING CORP. 485 Madison Ave., N.Y.C. Relays WABC daily, 1-5 p.m.</p>
<p>20700 kc. LSY -C- 14.49 meters MONTE GRANDE ARGENTINA Tests Irregularly</p>	<p>19160 kc. GAP -C- 15.66 meters RUGBY, ENGLAND Calls Australia, early a.m.</p>	<p>17780 kc. ★W3XAL -B- 16.87 meters NATIONAL BROAD. CO. BOUND BROOK, N. J. Relays WJZ, Daily exc. Sun. 8 a.m.-4 p.m.</p>	<p>15865 kc. CEC -C- 18.91 meters SANTIAGO, CHILE Works other S.A. stations afternoons</p>	<p>15260 kc. GSI -B- 19.66 meters DAVENTRY, B.B.C., BROADCASTING HOUSE, LONDON, ENGLAND 12:15-4 p.m.</p>
<p>20380 kc. GAA -C- 14.72 meters RUGBY, ENGLAND Calls Argentina, Brazil, mornings</p>	<p>18970 kc. GAQ -C- 15.81 meters RUGBY, ENGLAND Calls S. Africa, mornings</p>	<p>17775 kc. ★PHI -B- 16.88 meters HUIZEN, HOLLAND 8-10 a.m. daily except Tue. and Wed.</p>	<p>15810 kc. LSL -C- 18.98 meters HURLINGHAM, ARGENTINA Calls Brazil and Europe, daytime</p>	<p>15252 kc. RIM -C- 19.67 meters TACHKENT, U.S.S.R. Phones RKI near 7 a.m.</p>
	<p>18890 kc. ZSS -C- 15.88 meters KLIPHEUVEL, S. AFRICA Works Rugby 6:30 a.m.-12 n</p>	<p>17760 kc. ★W2XE -B- 16.89 meters ATLANTIC BROADCASTING CORP. 485 Madison Ave., N.Y.C.</p>	<p>15760 kc. JYT -X- 19.04 meters KEMIKWA-CHO, CHIBA, KEN, JAPAN Irregular in late afternoon and early morning</p>	<p>15250 kc. W1XAL -B- 19.67 meters BOSTON, MASS. Irregular, in morning</p>

(All Schedules Eastern Standard Time)

<p>15245 kc. ★TPA2 -B- 19.88 meters "RADIO COLONIAL" PARIS, FRANCE Service of la Radiodiffusion 98, bis. Blvd. Hausmann 2-3, 5:55-11 a.m.</p> <p>15230 kc. ★OLR -B- 19.70 meters "RADIO PODEBRADY," CZECHOSLOVAKIA Daily 1:30-4 p.m.</p> <p>15220 kc. ★PCJ -B- 19.71 meters N.V. PHILIPS' RADID EINDHOVEN, HOLLAND Tues. 4:30-6 a.m. Wed. 8-11 a.m. Sun. 6-7 a.m.</p> <p>15210 kc. ★W8XK -B- 19.72 meters WESTINGHOUSE ELECTRIC & MFG. CO. PITTSBURGH, PA. 9 a.m.-7 p.m. Relays KDKA</p> <p>15200 kc. ★DJB -B- 19.74 meters BROADCASTING HOUSE BERLIN, GERMANY 12:05-5:15, 5:55-11 a.m., 4:50- 10:55 p.m. Sun. also 11:10 a.m.-12:20 p.m.</p> <p>15180 kc. GSO -B- 19.78 meters DAVENTRY B.B.C., BROADCASTING HOUSE, LONDON, ENGLAND 3-5 a.m.</p> <p>15180 kc. RW96 -B- 19.76 meters MOSCOW, U.S.S.R. Sun. 1-2 p.m.</p> <p>15140 kc. ★GSF -B- 19.82 meters DAVENTRY, B.B.C., BROADCASTING HOUSE, LONDON, ENGLAND 6-8:45, 9 a.m.-12 n., 4:05- 5:45 p.m.</p> <p>15130 kc. PMH -B- 19.82 meters NIROM BANDONG, JAVA 5:30-11 a.m.</p> <p>15120 kc. HVJ -B- 19.83 meters VATICAN CITY 10:30 to 10:45 a.m., except Sunday Sat. 10-10:45 a.m.</p> <p>15110 kc. ★DJL -B- 19.85 meters BROADCASTING HOUSE, BERLIN, GERMANY 12-2, 8-9 a.m., 11:35 a.m.- 4:30 p.m. Irregular 4:50-10:45 p.m. Also 6-8 a.m. Sun.</p> <p>15090 kc. RKI -B, C- 19.88 meters MOSCOW, U.S.S.R. Phonics Tashkent near 7 a.m. and relays RNE on Sundays 10-11 a.m.</p> <p>15070 kc. PSD -C- 19.91 meters RIO DE JANEIRO, BRAZIL Calle N.Y., Buenos Aires and Europe, daytime</p> <p>15055 kc. WNC -C- 19.92 meters HIALEAH, FLORIDA Calls Central America, daytime</p> <p>14980 kc. KAY -C- 20.03 meters MANILA, P. I. Phonics Pacific Isles</p> <p>14970 kc. LZA -B, C- 20.04 meters RADIO GARATA, SOFIA, BULGARIA Broadcasts Sun. 12:30-8 a.m., 10 a.m.-4:30 p.m., Daily 3-7 a.m., Tues. and Thurs., 1-3 p.m.</p> <p>14960 kc. PSF -C- 20.43 meters RIO DE JANEIRO, BRAZIL Works with Buenos Aires daytime</p> <p>14950 kc. HJB -C- 20.07 meters BOGOTA, COL. Calls WNC, daytime</p> <p>14940 kc. HII -C- 20.08 meters CIUDAD TRUJILLO, D.R. Phonics WNC daytime</p> <p>14940 kc. HJA3 -C- 20.08 meters BARRANQUILLA, COL. Works WNC daytime</p>	<p>14845 kc. OCJ2 -C- 20.21 meters LIMA, PERU Works other S.A. stations daytime</p> <p>14653 kc. GBL -C- 20.47 meters RUGBY, ENGLAND Works JYM 1-7 a.m.</p> <p>14640 kc. TYF -C- 20.49 meters PARIS, FRANCE Works Saigon and Cairo 3-7 a.m., 12 n.-2:30 p.m.</p> <p>14600 kc. JVH -B, C- 20.55 meters, NAZAKI, JAPAN Phonics Europe 4-8 a.m. Broadcasts 12 m.-1 a.m., Tues. and Fri. 2-3 p.m., Mon. and Thurs. 4-5 p.m.</p> <p>14590 kc. WMN -C- 20.58 meters LAWRENCEVILLE, N. J. Phonics England morning and afternoon</p> <p>14535 kc. HBJ -B- 20.64 meters RADIO NATIONS, GENEVA, SWITZERLAND Broadcasts Irregularly</p> <p>14530 kc. LSN -C- 20.65 meters HURLINGHAM, ARGENTINA Calls N.Y.C., afternoons</p> <p>14500 kc. LSM2 -C- 20.69 meters HURLINGHAM, ARGENTINA Calls Rio and Europe daytime</p> <p>14485 kc. TIR -C- 20.71 meters CARTAGO, COSTA RICA Phonics Cen. Amer. & U.S.A. Daytime</p> <p>14485 kc. HPF -C- 20.71 meters PANAMA CITY, PAN. Phonics WNC daytime</p> <p>14485 kc. TGF -C- 20.71 meters GUATEMALA CITY, GUAT. Phonics WNC daytime</p> <p>14485 kc. YNA -C- 20.71 meters MANAGUA, NICARAGUA Phonics WNC daytime</p> <p>14485 kc. HRL5 -C- 20.71 meters NACOME, HONDURAS Works WNC daytime</p> <p>14485 kc. HRF -C- 20.71 meters TEGUCIGALPA, HONDURAS Works WNC daytime</p> <p>14470 kc. WMF -C- 20.73 meters LAWRENCEVILLE, N. J. Phonics England morning and afternoon</p> <p>14460 kc. DZH -C, X- 20.75 meters REICHSPOSTZENSTRALAMT, ZEESEN, GERMANY Irregular</p> <p>14440 kc. GBW -C- 20.78 meters RUGBY, ENGLAND Calls U.S.A., afternoons</p> <p>13990 kc. GBA -C- 21.44 meters RUGBY, ENGLAND Calls Buenos Aires, late afternoon</p> <p>13820 kc. SUZ -C- 21.71 meters ABOU ZABAL, EGYPT Works with Europe 11 a.m.-2 p.m.</p> <p>13690 kc. KKZ -C- 21.91 meters RCA COMMUNICATIONS, BOLINAS, CAL. Tests Irregularly</p> <p>13635 kc. SPW -B- 22 meters WARSAW, POLAND Mon., Wed., Fri. 11:30 a.m.- 12:30 p.m. Irregular at other times</p> <p>13610 kc. JYK -C- 22.04 meters KEMIKAWA-CHO, CHIBA- KEN, JAPAN Phonics California till 11 p. m.</p> <p>13585 kc. GBB -C- 22.08 meters RUGBY, ENGLAND Calls Egypt & Canada, afternoons</p>	<p>13415 kc. GCJ -C- 22.38 meters RUGBY, ENGLAND Calls Japan & China early morning</p> <p>13390 kc. WMA -C- 22.40 meters LAWRENCEVILLE, N. J. Phonics England morning and afternoon</p> <p>13380 kc. IDU -C- 22.42 meters ASMARA, ERITREA, AFRICA Works with Rome daytime</p> <p>13345 kc. YVQ -C- 22.48 meters MARACAY, VENEZUELA Calls Hialeah daytime</p> <p>13285 kc. CGA3 -C- 22.58 meters DRUMMONDVILLE, QUE., CAN. Works London and Ships afternoons</p> <p>13075 kc. VPD -X- 22.94 meters SUVA, FIJI ISLANDS Daily exc. Sun. 12:30-1:30 a.m.</p> <p>12840 kc. WOO -C- 23.36 meters OCEAN GATE, N. J. Calls ships</p> <p>12825 kc. CNR -B, C- 23.39 meters DIRECTOR GENERAL Telegraph and Telephone Stations, Rabat, Morocco Broadcasts, Sunday, 7:30-9 a. m.</p> <p>12800 kc. IAC -C- 23.45 meters PISA, ITALY Calls Italian ships, mornings</p> <p>12780 kc. GBC -C- 23.47 meters RUGBY, ENGLAND Calls ships</p> <p>12396 kc. CT1G0 -B- 24.2 meters PAREDE, PORTUGAL Sun. 10-11:30 a.m., Tues., Thurs., Fri. 1:00-2:15 p.m.</p> <p>12325 kc. DAF -C- 24.34 meters NORDEICH, GERMANY Works German ships daytime</p> <p>12290 kc. GBU -C- 24.41 meters RUGBY, ENGLAND Calls N.Y.C., afternoon</p> <p>12250 kc. TYB -C- 24.49 meters PARIS, FRANCE Irregular</p> <p>12235 kc. ★TFJ -B, C- 24.52 meters REYKJAVIK, ICELAND Phonics England mornings, Broadcasts Sun. 1:40-2:30 p.m.</p> <p>12215 kc. TYA -C- 24.56 meters PARIS, FRANCE Works French Ships in morning and afternoon</p> <p>12150 kc. GBS -C- 24.69 meters RUGBY, ENGLAND Calls N.Y.C., afternoon</p> <p>12130 kc. DZE -C, X- 24.73 meters REICHSPOSTZENSTRALAMT, ZEESEN, GERMANY Tests Irregularly</p> <p>12060 kc. PDV -C- 24.88 meters KOOTWIJK, HOLLAND Tests Irregular</p> <p>12000 kc. RNE -B- 25 meters MOSCOW, U. S. S. R. Sun. 6-9, 10-11 a.m., 12:30- 6 p. m. Wed. 6-7 a. m. Daily 12:30-6 p. m.</p> <p>11991 kc. FZS2 -C- 25.02 meters SAIGON, INDO-CHINA Phonics Paris, morning</p> <p>11950 kc. KKQ -X- 25.10 meters BOLINAS, CALIF. Tests, Irregularly, evenings</p> <p>11940 kc. FTA -C- 25.13 meters STE. ASSISE, FRANCE Phonics CNR morning Hurlingham, Arge., nights</p>	<p>11880 kc. ★TPA3 -B- 25.23 meters "RADIO COLONIAL" PARIS, FRANCE 2-5 a.m., 12:15-6 p.m.</p> <p>11870 kc. ★W8XK -B- 25.26 meters WESTINGHOUSE ELECTRIC & MFG. CO. PITTSBURGH, PA. 5-10:30 p.m. Fri. till 12 m Relays KDKA</p> <p>11860 kc. YDB -B- 25.29 meters N.I.R.O.M., SOERABAJA, JAVA Sat. 7:30 p.m.-2 a.m. (Sun.) Daily 10:30 p.m.-2 a.m.</p> <p>11860 kc. GSE -B- 25.29 meters DAVENTRY, B.B.C., BROADCASTING HOUSE, LONDON, ENGLAND</p> <p>11855 kc. DJP -B, X- 25.31 meters BROADCASTING HOUSE, BERLIN, GERMANY Irregular</p> <p>11830 kc. W9XAA -B- 25.36 meters CHICAGO FEDERATION OF LABOR CHICAGO, ILL. Relays WFL 6:30 a.m.-4 p.m., 9 p.m.-12 m.</p> <p>11830 kc. ★W2XE -B- 25.36 meters ATLANTIC BROADCASTING CORP. 485 MADISON AVE., N. Y. C. Relays WABC 5-11 p.m.</p> <p>11820 kc. GSN -B- 25.38 meters DAVENTRY HOUSE, LONDON, ENGLAND 3-5 a.m., Irregular</p> <p>11810 kc. ★HJ4ABA -B- 25.4 meters P. O. BOX 50, MEDELLIN, COLOMBIA 11:30 a.m.-1 p.m., 6:30-10:30 p.m.</p> <p>11810 kc. ★2RO -B- 25.4 meters E.I.A.R. Via Montello 5 ROME, ITALY Daily 6:43-10:30, 11:30 a.m.- 5:30 p.m. 6:30-11 p.m.: Sun, 6:43-9, 11:30 a.m.-5:30 p.m. Also Mon., Wed., Fri., 6:20- 7:30 p.m.</p> <p>11795 kc. DJO -B, X- 25.43 meters BROADCASTING HOUSE, BERLIN, GERMANY Irregular</p> <p>11790 kc. W1XAL -B- 25.45 meters BOSTON, MASS. Daily 5:15-6:15 p.m. Sun. 5-7 p.m.</p> <p>11770 kc. ★DJD -B- 25.49 meters BROADCASTING HOUSE, BERLIN, GERMANY 11:35 a.m.-4:30 p.m.; 4:50- 10:55 p.m.</p> <p>11760 kc. ★OLR -B- 25.51 meters "RADIO PODEBRADY" CZECHOSLOVAKIA Broadcasts 9-11 p.m. Mon. and Thurs.</p> <p>11750 kc. ★GSD -B- 25.53 meters DAVENTRY B.B.C., BROADCASTING HOUSE, LONDON, ENGLAND 12:15-5:45 p.m., 6-8, 9-11 p.m.</p> <p>11730 kc. PHI -B- 25.57 meters HUIZEN, HOLLAND Irregular</p> <p>11720 kc. ★CJRX -B- 25.6 meters WINNIPEG, CANADA Daily, 8 p. m.-12 m.</p> <p>11715 kc. ★TPA4 -B- 25.61 meters "RADIO COLONIAL" PARIS, FRANCE 6:15-10:15 p.m. 10:45 p.m.-1 a.m.</p> <p>11680 kc. KIO -X- 25.68 meters KAHUKU, HAWAII Tests in the evening</p>	<p>11595 kc. VRR4 -C- 25.87 meters STONY HILL, JAMAICA, B.W.I. Works WNC daytime.</p> <p>11560 kc. VIZ3 -X- 25.95 meters AMALGAMATED WIRELESS OF AUSTRALASIA FISKVILLE, AUSTRALIA Calls Canada evening and early a.m.</p> <p>11500 kc. COCX -B- 25.96 meters HAVANNA, CUBA Relays CMX Irregularly 5 p.m.-1 a.m.</p> <p>11500 kc. PMK -B, C- 26.09 meters BANDONG, JAVA Broadcasts Daily exc. Sat. 5:30- 10:30 or 11 a.m., 6-7:30 p.m., 10:30 p.m.-2 a.m., Sat. 5:30- 11:30 a.m., 7:30 p.m.-2 a.m. (Sun.)</p> <p>11413 kc. CJA4 -C- 26.28 meters DRUMMONDVILLE, QUE., CAN. Tests with Australia Irregularly in evenings</p> <p>11280 kc. HIN -B- 26 meters LA VOZ DEL PARTIDO DOMINICANO, CIUDAD TRUJILLO, D.R. 12-2 p.m., 7:30-9:30 p.m.</p> <p>11200 kc. XBJQ -X- 26.79 meters BOX 2825, MEXICO CITY, MEX. Irregular</p> <p>11050 kc. ZLT4 -C- 27.15 meters WELLINGTON, N. ZEALAND Phonics Australia and England early a.m.</p> <p>10970 kc. OCI -C- 27.35 meters LIMA, PERU Works with Bogota, Col., evenings</p> <p>10955 kc. HS8PJ -B, X- 27.38 meters BANGKOK, SIAM Broadcasts 8-10 a.m. Mondays</p> <p>10840 kc. KWW -C- 27.68 meters DIXON, CAL. Works with Hawaii evenings.</p> <p>10770 kc. GBP -C- 27.85 meters RUGBY, ENGLAND Calls Sydney, Austral. early a. m.</p> <p>10740 kc. ★JVM -B, C- 27.93 meters NAZAKI, JAPAN Broadcasts Tues. and Fri. 2-3 p.m., Phonics U.S. 2-7 a.m.</p> <p>10675 kc. WNB -C- 28.1 meters LAWRENCEVILLE, N. J. Calls Bermuda, daytime</p> <p>10670 kc. ★CEC -C- 28.12 meters SANTIAGO, CHILE Broadcasts Daily 7-7:15 p.m.</p> <p>10660 kc. ★JVN -B, C- 28.14 meters NAZAKI, JAPAN Phonics Europe 3-8 a.m., Broadcasts daily 12 m.-1 a.m., 2-8 a.m. Mon. and Thurs. 4-5 p.m.</p> <p>10550 kc. WOK -C- 28.44 meters LAWRENCEVILLE, N. J. Phonics Arge., Braz., Peru, nights</p> <p>10520 kc. VLK -C- 28.51 meters SYDNEY, AUSTRALIA Calls Rugby, early a.m.</p> <p>10430 kc. YBG -C- 28.76 meters MEDAN, SUMATRA 5:30-6:30 a. m., 7:30-8:30 p. m.</p> <p>10420 kc. XGW -C- 28.79 meters SHANGHAI, CHINA Calls Manila and England, 6-9 a. m. and California late evening</p> <p>10410 kc. PDK -C- 28.80 meters KOOTWIJK, HOLLAND Calls Java 7:30-9:40 a. m.</p> <p>10410 kc. KES -X- 28.80 meters BOLINAS, CALIF. Tests evenings</p>
--	---	---	---	--

(All Schedules Eastern Standard Time)

10350 kc. LSX
 -C- 28.98 meters
MONTE GRANDE, ARGENTINA
 Tests irregularly 8 p.m.-12 mid-night.

10330 kc. ORK
 -B-C- 29.04 meters
RUYSELEDE, BELGIUM
 Broadcasts 2:30-4 p.m.

10300 kc. LSL2
 -C- 28.13 meters
HURLINGHAM, ARGENTINA
 Calls Europe, evenings

10290 kc. DZC
 -X- 29.16 meters
REICHSPOSTZENTRALAMET, ZEESEN, GERMANY
 Broadcasts irregularly

10260 kc. PMN
 -B-C- 29.74 meters
BANDOENG, JAVA
 Calls Australia 5 a.m.
 Broadcasts Daily exc. Sat. 6-7:30 p.m., 10:30 p.m.-2 a.m., 5:30-10:30 or 11 a.m., Sat. 5:30-11:30 a.m., 7:30 p.m.-2 a.m. (Sun.)

10250 kc. LSK3
 -C- 29.27 meters
HURLINGHAM, ARGENTINA
 Calls Europe and U. S., afternoon and evening

10220 kc. PSH
 -C- 29.35 meters
RIO DE JANEIRO, BRAZIL

10170 kc. RIO
 -C- 29.5 meters
BAKOU, U.S.S.R.
 Works with Moscow 10 p.m.-5 a.m.

10169 kc. HSJ
 -CX- 29.5 meters
BANGKOK, SIAM
 Tests 9-10 a.m., Mon., Wed., Thur.

10140 kc. OPM
 -C- 29.59 meters
LEOPOLDVILLE, BELGIAN CONGO
 Phones around 3 a.m. and 1-3 p.m.

10080 kc. RIR
 -C- 29.76 meters
TIFLIS, U.S.S.R.
 Works with Moscow early morning.

10070 kc. EDM-EHY
 -C- 29.79 meters
MADRID, SPAIN
 Works with S. America evenings

10055 kc. ZFB
 -C- 29.84 meters
HAMILTON, BERMUDEA
 Phones N. Y. C. daytime

10055 kc. SUV
 -C- 29.84 meters
ABOU ZABAL, EGYPT
 Works with Europe 1-6 p.m.

10042 kc. DZB
 -X- 29.87 meters
ZEESEN, GERMANY
 Irregular

9990 kc. KAZ
 -C- 30.03 meters
MANILLA, P.I.
 Works with Java, Cal. and ships early morning

9950 kc. GCU
 -C- 30.15 meters
RUGBY, ENGLAND
 Calls N.Y.C. evening

9930 kc. HKB
 -C- 30.21 meters
BOGOTA, COL.
 Phones Rio de Janeiro evenings

9890 kc. LSN
 -C- 30.33 meters
HURLINGHAM, ARGENTINA
 Calls New York, evenings

9870 kc. WON
 -C- 30.4 meters
LAWRENCEVILLE, N. J.
 Phones England, evening

9860 kc. EAQ
 -B- 30.43 meters
P. O. Box 951 MADRID, SPAIN
 Daily 5:15-9:30 p.m.; Saturday also 12 n.-2 p.m.

9840 kc. JYS
 -X- 30.49 meters
KEMIKAWA-CHO, CHIBAKEN, JAPAN
 Irregular, 11:30 p.m.-3 a.m.

9840 kc. TI4NRH
 -B- 30.5 meters
AMANDO CESPEDES MARIN, APARTADO 40, HEREDIA, COSTA RICA
 Daily 8:30-10, 11:30 p.m.-12 m.

9830 kc. COCQ
 -B- 30.55 meters
HAVANA, CUBA
 Evenings

9800 kc. LSI
 -C- 30.81 meters
MONTE GRANDE, ARGENTINA
 Tests irregularly

9790 kc. GCW
 -C- 30.64 meters
RUGBY, ENGLAND
 Calls N.Y.C., evening

9760 kc. VLJ-VLZ2
 -C- 30.74 meters
AMALGAMATED WIRELESS OF AUSTRALIA
SYDNEY, AUSTRALIA
 Phones Java and N. Zealand early a.m.

9750 kc. WOF
 -C- 30.77 meters
LAWRENCEVILLE, N. J.
 Phones England, evening

9710 kc. GCA
 -C- 30.89 meters
RUGBY, ENGLAND
 Calls Arge. & Brazil, evenings

9675 kc. DZA
 -C- 31.01 meters
ZEESEN, GERMANY
 Irregular

9650 kc. YDB
 -B- 31.09 meters
N.I.R.O.M., SOERABAJA, JAVA
 Daily exc. Sat. 6-7:30 p.m., 5:30-10:30 or 11 a.m., Sat. 5:30-11:30 a.m.

9650 kc. CT1AA
 -B- 31.09 meters
"RADIO COLONIAL" LISBON, PORTUGAL
 Tues., Thurs., Sat. 4-7 p.m.

9650 kc. DGU
 -C- 31.09 meters
NAUEN, GERMANY
 Works with Egypt in afternoon

9645 kc. YNLF
 -B- 31.1 meters
MANAGUA, NICARAGUA
 8-9 a.m., 12:30-2:30, 6:30-10 p.m.

9640 kc. LRX
 -B- 31.12 meters
"EL MUNDO" BUENOS AIRES, ARGENTINA
 5-9 p.m.

9635 kc. 2RO
 -B- 31.13 meters
E.I.A.R., ROME, ITALY
 Tues., Thurs., Sat. 6:30-8 p.m.

9615 kc. HJ1ABP
 -B- 31.2 meters
P.O. BDX 37, CARTAGENA, COL.
 11 a.m.-1 p.m. 5-11 p.m., Sun. 10 a.m.-1 p.m., 3-6 p.m.

9605 kc. HP5J
 -B- 31.24 meters
APARTADO 867, PANAMA CITY, PANAMA
 12n-1:30 p.m., 6-10:30 p.m.

9600 kc. RAN
 -B- 31.25 meters
MOSCOW, U.S.S.R.
 Daily 7-7:30 p.m., Sun., Wed. and Fri. 6-8 p.m.

9600 kc. CB960
 -B- 31.25 meters
SANTIAGO, CHILE
 9:30 p.m. on

9595 kc. HBL
 -B- 31.27 meters
LEAGUE OF NATIONS GENEVA, SWITZERLAND
 Saturdays, 5:30-6:15 p. m. Mon. at 1:45 a.m.

9595 kc. HH3W
 -B- 31.27 meters
P.O. Box 1117, PORT-AU-PRINCE, HAITI
 1-2, 7-8:30 p.m.

9590 kc. PCJ
 -B- 31.28 meters
N. V. PHILIPS RADIO EINDHOVEN, HOLLAND
 Sun. 2-3, 7-8 p.m. Tues. 1:30-3 p.m. Wed. 7-10 p.m.

9590 kc. VK2ME
 -B- 31.29 meters
AMALGAMATED WIRELESS, LTD., 47 YORK ST. SYDNEY, AUSTRALIA
 Sun. 12:30-2:30 a.m., 4:30-8:30 a.m., 9:30-11:30 a.m.

9590 kc. W3XAU
 -B- 31.28 meters
PHILADELPHIA, PA.
 Relays WCAU Daily 12n-8 p.m.

9585 kc. CQN
 -B- 31.30 meters
MACAO, PORTUGUESE CHINA
 Mon. and Fri. 7-8:30 a.m.

9580 kc. GSC
 -B- 31.32 meters
DAVENTRY, B.B.C., BROADCASTING HOUSE, LONDON, ENGLAND
 6-8, 9-11 p.m.

9580 kc. VK3LR
 -B- 31.32 meters
Research Section, Postmaster Gen'l's. Dept., 81 Little Collins St., MELBOURNE, AUSTRALIA
 3:15-7:30 a.m., except Sun. also Fr. 10 p.m.-2 a.m.

9570 kc. W1XK
 -B- 31.35 meters
WESTINGHOUSE ELECTRIC & MFG. CO. SPRINGFIELD, MASS.
 Relays WBZ. 7 a.m.-1 a.m. Sun. 8 a.m.-1 a.m.

9565 kc. VUB
 -B- 31.36 meters
BOMBAY, INDIA
 11 a.m.-12:30 p.m., Wed., Thurs., Sat.

9560 kc. DJA
 -B- 31.38 meters
BROADCASTING HOUSE, BERLIN
 12:05-5:15 a.m., 4:50-10:45 p.m.

9555 kc. HJ1ABB
 -B- 31.38 meters
BARRANQUILLA, COL. S.A. P. O. BOX 715
 11:30 a.m.-1 p.m., 4:30-10 p.m.

9540 kc. DJN
 -B- 31.45 meters
BROADCASTING HOUSE BERLIN, GERMANY
 12:05-5:15 a.m., 4:50-10:45 p.m.

9540 kc. VPD2
 -B- 31.45 meters
SUVA, FIJI ISLANDS
AMALGAMATED WIRELESS OF AUSTRALASIA
 Daily except Sun. 5:30-8 a.m.

9530 kc. W2XAF
 -B- 31.48 meters
GENERAL ELECTRIC CO. SCHENECTADY, N. Y.
 Relays WGY 4 p.m.-12 m.

9525 kc. LKJ1
 -B- 31.49 meters
JELOY, NORWAY
 5-8 a.m., 11 a.m.-6 p.m.

9510 kc. VK3ME
 -B- 31.55 meters
AMALGAMATED WIRELESS, Ltd. 167 Queen St., MELBOURNE, AUSTRALIA
 Daily exc. Sun. 4-7 a.m.

9510 kc. GSB
 -B- 31.55 meters
DAVENTRY, B.B.C., BROADCASTING HOUSE, LONDON, ENGLAND
 3-5 a.m., 9 a.m.-12 n. 12:15-5:45, 6-8 p.m.

9500 kc. HJU
 -B- 31.58 meters
NATIONAL RAILWAYS BUENAVENTURA, COLOMBIA
 Mon., Wed., Fri. 8-11 p.m.

9500 kc. HJ1ABE
 -B- 31.58 meters
P.D. BDX 31, CARTAGENA, COLOMBIA
 Daily 7:30-9 p.m. Mon. also 10 p.m.-12 m.

9500 kc. PRF5
 -B- 31.58 meters
RIO DE JANEIRO, BRAZIL
 Irregularly 4:45-5:45 p.m.

9450 kc. TGW
 -B- 31.75 meters
MINISTRE de FOMENTO GUATEMALA CITY, GUATEMALA
 Daily 11 a.m.-1 p.m. 7-8, 9-11 p.m., Sat. 9 p.m.-5 a.m. (Sun.)

9428 kc. COCH
 -B- 31.8 meters
2 B ST., VEDADO, HAVANA, CUBA
 Daily 8 a.m.-7 p.m. Sun. 11 a.m.-12 n., 6:30-9:30 p.m.

9415 kc. PLV
 -C- 31.87 meters
BANDOENG, JAVA
 Phones Holland around 9:45 a.m.

9330 kc. CGA4
 -C- 32.15 meters
DRUMMONDVILLE, CANADA
 Phones England Irregularly

9280 kc. GCB
 -C- 32.33 meters
RUGBY, ENGLAND
 Calls Can. & Egypt, evenings

9170 kc. WNA
 -C- 32.72 meters
LAWRENCEVILLE, N. J.
 Phones England, evening

9150 kc. YVR
 -C- 32.79 meters
MARACAY, VENEZUELA
 Works with Europe afternoons.

9125 kc. HAT4
 -B- 32.88 meters
"RADIOLABOR," GYALI-UT, 22 BUDAPEST, HUNGARY
 Sunday 6-7 p.m.

9060 kc. TFK
 -C- 33.11 meters
REYKJAVIK, ICELAND
 Phones London afternoons. Broadcasts Irregularly.

9020 kc. GCS
 -C- 33.26 meters
RUGBY, ENGLAND
 Calls N.Y.C., evenings

9010 kc. KEJ
 -C- 33.3 meters
BOLINAS, CAL.
 Relays NBC & CBS Programs in evening Irregularly

8975 kc. VWY
 -C- 33.43 meters
KIRKEE, INDIA
 Works with England in morning

8950 kc. HCJB
 -B- 33.5 meters
QUITO, ECUADOR
 7:30-9:30 p.m., except Monday Sun. 11 a.m.-12 n.; 4-10 p.m.

8795 kc. HKV
 -B- 34.09 meters
BOGOTA, COLOMBIA
 Irregularly; 6:30 p.m.-12 m.

8775 kc. PNI
 -C- 34.19 meters
MAKASSER, CELEBES, N.I.
 Phones Java around 4 a. m.

8765 kc. DAF
 -C- 34.23 meters
NORDEICH, GERMANY
 Works German Ships Irregularly

8760 kc. GCQ
 -C- 34.25 meters
RUGBY, ENGLAND
 Calls S. Africa, afternoon

8750 kc. ZCK
 -B- 34.29 meters
HONGKONG, CHINA
 Relays ZBW Daily 11:30 p.m.-1:15 a.m. Mon. and Thurs. 3-7 a.m. Tues., Wed., Fri. 8-10 a.m. Sat. 6-11 a.m.

8730 kc. GCI
 -C- 34.38 meters
RUGBY, ENGLAND
 Calls India. 8 a. m.

8680 kc. GBC
 -C- 34.56 meters
RUGBY, ENGLAND
 Calls ships

8665 kc. CO9JQ
 -X- 34.62 meters
4 GENERAL GOMEZ CAMAGUEY, CUBA
 5:30-6:30, 8-9 p.m. daily except Sat. and Sun.

8590 kc. YNVA
 -B- 34.92 meters
MANAGUA, NICARAGUA
 7:30-9:30 p. m.

8560 kc. WOO
 -C- 35.05 meters
OCEAN GATE, N. J.
 Calls ships Irregularly

8400 kc. HC2AT
 -B- 35.71 meters
CASSILLA 877 GUAYACUIL, ECUADOR
 8-11 p.m.

8380 kc. IAC
 -C- 35.8 meters
Pisa, Italy

8190 kc. XEME
 -B- 36.63 meters
CALLE 59, No. 517 MERIDA, YUCATAN
"LA VDZ de YUCATAN desde MERIDA
 10 a.m.-12 n., 6 p.m.-12 m.

8185 kc. PSK
 -C- 38.65 meters
RIO DE JANEIRO, BRAZIL
 Irregularly

8036 kc. CNR
 -B- 37.33 meters
RABAT, MOROCCO
 Sunday, 2:30-5 p. m.

7975 kc. HC2TC
 -B- 37.62 meters
QUITO, ECUADOR
 Thurs., Sun. at 8 p.m.

7901 kc. LSL
 -C- 37.97 meters
HURLINGHAM, ARGENTINA
 Calls Brazil, night

7880 kc. JYR
 -B- 38.07 meters
KEMIKAWA-CHO, CHIBAKEN, JAPAN
 4-7:40 a. m.

7860 kc. SUX
 -C- 38.17 meters
ABOU ZABAL, EGYPT
 Works with Europe 4-6 p.m.

7854 kc. HC2JSB
 -B- 38.2 meters
GUAYACUIL, ECUADOR
 6:15-11:15 p.m.

7799 kc. HBP
 -B- 38.47 meters
LEAGUE OF NATIONS, GENEVA, SWITZERLAND
 5:30-6:15 p. m., Saturday

7715 kc. KEE
 -C- 38.89 meters
BOLINAS, CAL.
 Relays NBC & CBS Programs in evening Irregularly

7630 kc. ZHJ
 -B- 39.32 meters
PENANG, MALAYA
 Daily 7-9 a.m. also Sat. 11 p.m.-1 A.M. (Sun.)

7626 kc. RIM
 -C- 39.34 meters
TACHKENT, U.S.S.R.
 Works with Moscow early morning

7610 kc. KWX
 -C- 39.42 meters
DIXON, CAL.
 Works with Hawaii, Philippines, Java and Japan nights.

7550 kc. TI8WS
 -B- 39.74 meters
"ECOB DEL PACIFICO" P. O. BOX 75 PUNTA ARENAS, COSTA RICA
 8 p.m.-12 m.

7520 kc. KKH
 -C- 39.89 meters
KAHUKU, HAWAII
 Works with Dixon and broadcasts Irregularly nights

7510 kc. JVP
 -B-C- 39.95 meters
NAZAKI, JAPAN

7500 kc. RKI
 -C- 40 meters
MOSCOW, U.S.S.R.
 Works RIM early a.m.

7390 kc. ZLT2
 -C- 40.6 meters
WELLINGTON, N.Z.
 Works with Sydney 3-7 a.m.

7380 kc. XECR
 -B- 40.65 meters
FOREIGN OFFICE, MEXICO CITY, MEX.
 Sun. 6-7 p.m.

7281 kc. HJ1ABD
 -B- 41.04 meters
CARTAGENA, CDLO.
 Irregularly, evenings

7100 kc. HKE
 -B- 42.25 meters
BOGOTA, COL. S. A.
 Tue. and Sat. 8-9 p. m.; Mon. & Thurs. 6:30-7 p. m.

7080 kc. VP3MR
 -B- 42.68 meters
GEORGETOWN, BRI. GUIANA, S.A.
 Sun. 7:45-10:15 a.m. Daily 4:45-8:45 p.m.

7074 kc. HJ1ABK
-B. 42.69 meters
CALLE BOLIVIA,
PROGRESO-IGUALDAD
BARRANQUILLA, COLOMBIA
Sun. 3-6 p.m.

7030 kc. HRP1
-B. 42.67 meters
SAN PEDRO SULA,
HONDURAS
Reported on this and other waves
irregularly in evening

6996 kc. PZH
-B. 42.88 meters
P. O. BOX 18,
PARAMIRABO, DUTCH
GUIANA
Sun. 9:36-11:36 a.m.
Mon. and Fri. 5:36-9:36 p.m.
Tues. and Thur. 8:36-10:36 a.m.
2:36-4:36 p.m.
Wed. 3:36-4:36, 5:36-9:36 p.m.
Sat. 2:36-4:36 p.m.

6976 kc. HCETC
-B. 43 meters
TEATRO BOLIVAR
QUITO, ECUADOR
Thurs. till 9:30 p.m.

6905 kc. GDS
-C. 43.45 meters
RUGBY, ENGLAND
Calls N.Y.C. evening

6860 kc. KEL
-X. 43.70 meters
BOLINAS CALIF.
Tests irregularly
11 a.m.-12 n.; 6-9 p.m.

6850 kc. TIGOW
-B. 43.8 meters
ONDA del CARIBE
PUERTO LIMON, COSTA
RICA
Irregularly 8-9:30 p.m.

6800 kc. HI7P
-B. 44.12 meters
EMISORIA DIARIA de COM-
ERCIO, CIUDAD TRUJILLO,
DOM. REP.
Daily exc. Sat. and Sun. 12:40-
1:40, 6:40-8:40 p.m.; Sat. 12:40-
1:40 p.m.; Sun. 10:40 a.m.-
11:40 a.m.

6780 kc. HIH
-B. 44.25 meters
SAN PEDRO de MACORIS
DOMINICAN REP.
12:10-1:40 p.m.; 7:30-9 p.m.;
Sun. 3-4 a.m.; 4:15-6 p.m.

6755 kc. WOA
-C. 44.41 meters
LAWRENCEVILLE, N. J.
Phones England, evening

6750 kc. JVT
-B.C. 44.44 meters
NAZAKI, JAPAN
KOKUSAI-DENWA KAISHA,
LTD., TOKIO

6730 kc. HI3C
-B. 44.58 meters
"LA VOZ DE LA FERIA"
LA ROMANA, DOM. REP.
11:55 a.m.-1:25 p.m.,
6:10 p.m.-12 m.

6710 kc. TIEP
-B. 44.71 meters
LAVOZ DEL TROPICO
SAN JOSE, COSTA RICA
APARTADO 257, Daily 7-10
p.m.

6690 kc. XGOX
-B. 44.84 meters
NANKING, CHINA
6:30-9 a.m.

6672 kc. YVQ
-C. 44.95 meters
MARACAY, VENEZUELA
Broadcasts Sat. 8-9 p.m.

6650 kc. IAC
-C. 45.11 meters
PISA, ITALY
Calls ships, evenings

6635 kc. HC2RL
-B. 45.21 meters
P. O. BOX 759, GUAYAQUIL,
ECUADOR, S. A.
Sunday, 5:45-7:45 p.m.
Tues., 9:15-11:15 p.m.

6630 kc. HIT
-B. 45.25 meters
"LA VOZ de la RCA VICTOR,"
APARTADO 1105, CIUDAD
TRUJILLO, D.R.
Daily exc. Sun. 12:10-1:40 p.m.,
5:40-8:40 p.m., also Sat. 10:40
p.m.-12:40 a.m. (Sun.)

6625 kc. PRADO
-B. 45.28 meters
RIOBAMBA, ECUADOR
Thurs. 9-11:45 p.m.

6600 kc. HI8A
-B. 45.45 meters
CIUDAD TRUJILLO, DOM.
REP.
Irregular

6558 kc. HI4D
-B. 45.74 meters
CIUDAD TRUJILLO, DDM-
INICAN REPUBLIC
Except Sun. 11:55 a.m.-1:40
p.m.; 4:40-7:40 p.m.

6550 kc. TIRCC
-B. 45.8 meters
RADIOEMISORA CATOLICA
COSTARRICENSE
SAN JOSE, COSTA RICA
Sun. 11 a.m.-2 p.m., 6-7, 8-9
p.m., Daily 12 n.-2 p.m., 6-7
p.m., Thurs. 6-11 p.m.

6545 kc. YV11RB
-B. 45.84 meters
"ECOS de ORINOCO"
BOLIVAR, VENEZUELA
6-10:30 p.m.

6520 kc. YV6RV
-B. 46.01 meters
VALENCIA, VENEZUELA
11 a.m.-2 p.m.; 5-10 p.m.

6500 kc. HIL
-B. 46.15 meters
APARTADO 623
CIUDAD TRUJILLO, D.R.
12:10-1:40 p.m., 5:40-
7:40 p.m.

6477 kc. HI4V
-B. 46.32 meters
CIUDAD TRUJILLO, D.R.
LA VOZ de LA MARINA
11:40 a.m.-1:40 p.m.; 5:10-9:40
p.m.

6450 kc. HJ4ABC
-B. 46.51 meters
APARTADO 39
IBAQUE, COLOMBIA
11 a.m.-12 n.; 8-11 p.m.

6425 kc. W9XBS
-X. 46.7 meters
NATL. BROAD. CO.
CHICAGO, ILL.
Relays WMAQ, Irregular

6420 kc. HI1S
-B. 46.73 meters
PUERTO PLATA, DOM. REP.
11:40 a.m.-1:40 p.m., 5:40-
7:40, 9:40-11:40 p.m.

6410 kc. TIPG
-B. 46.8 meters
APARTADO 225,
SAN JOSE, COSTA RICA
"LA VOZ DE LA VICTOR"
12 n.-2 p.m., 6-11:30 p.m.

6400 kc. YV9RC
-B. 46.88 meters
CARACAS, VENEZUELA
7-11 p.m.

6380 kc. YV4RC
-B. 47.02 meters
CARACAS, VENEZUELA
5:30-9:30 p.m.

6316 kc. HIZ
-B. 47.5 meters
CIUDAD TRUJILLO
DOMINICAN REPUBLIC
Daily except Sat. and Sun.
11:10 a.m.-2:25 p.m., 5:10-8:40
p.m.; Sat. 5:10-11:10 p.m.;
Sun., 11:40 a.m.-1:40 p.m.

6300 kc. YV12RM
-B. 47.62 meters
MARACAY, VENEZUELA
8-10:30 p.m.

6282 kc. CO9WR
-B. 47.76 meters
P.O. BOX 85,
SANCTI SPIRITUS, CUBA
4-6, 9-11 p.m.

6280 kc. HIG
-B. 47.77 meters
CIUDAD TRUJILLO, D.R.
7:10-8:40 a.m., 12:40-2:10,
8:10-9:40 p.m.

6243 kc. HIN
-B. 48 meters
CIUDAD TRUJILLO, D.R.
LA VOZ del PARTIDO
DOMINICANO
12 n.-2 p.m., 7:30-9:30 p.m.

6235 kc. HRD
-B. 48.12 meters
LA VOZ de ATLANTIDAS
LA CEIBA, HONDURAS
8-11 p.m., Sat. 8 p.m.-1 a.m.
(Sun.); Sun. 4-6 p.m.

6230 kc. OAX4G
-B. 48.15 meters
Apartado 1242
LIMA, PERU
Daily 7-10:30 p.m.
Wed. 6-10:30 p.m.

6185 kc. HI1A
-B. 48.5 meters
P. O. BOX 423, SANTIAGO,
DOMINICAN REP.
11:40 a.m.-1:40 p.m.,
7:40-9:40 p.m.

6175 kc. HJ2ABA
-B. 48.58 meters
TUNJA, COLOMBIA
1-2; 7:30-9:30 p.m.

6171 kc. XEXA
-B. 48.61 meters
DEPT. OF EDUCATION
MEXICO CITY, MEX.
7-11 p.m.

6170 kc. HJ3ABF
-B. 48.62 meters
BOGOTA, COLOMBIA
7-11:15 p.m.

6160 kc. YV3RC
-B. 48.7 meters
CARACAS, VENEZUELA
11 a.m.-2 p.m., 4-10:30 p.m.

6150 kc. CSL
-B. 48.78 meters
LISBON, PORTUGAL
7-8:30 a.m., 2-7 p.m.

6150 kc. CJRO
-B. 48.78 meters
WINNIPEG, MAN., CANADA
8 p.m.-12 m.
Sun. 3-10:30 p.m.

6147 kc. COKG
-B. 48.8 meters
BOX 137, SANTIAGO, CUBA
9-10 a.m., 11:30 a.m.-1:30 p.m.,
3-4:30 p.m., 10-11 p.m., 12 m.-
2 a.m.

6140 kc. W8XK
-B. 48.86 meters
WESTINGHOUSE ELECTRIC
& MFG. CO.
PITTSBURGH PA.
Relays KDKA
9 p.m.-1 a.m.

6135 kc. HJ1ABB
-B. 48.9 meters
BARRANQUILLA, COL., S. A.
P. O. BOX 715,
11:30 a.m.-1 p.m.; 4:30-10 p.m.

6135 kc. HI5N
-B. 48.9 meters
SANTIAGO, D.R.
6:40-9:10 p.m.

6135 kc. HJ4ABP
-B. 48.9 meters
MEDELLIN, COL.
Relays HJ4ABQ 8-11 p.m.

6132 kc. HIX
-B. 48.93 meters
CIUDAD TRUJILLO,
DOMINICAN REP.
Sun. 7:40-10:10; Daily 12:40-
1:10 p.m., 4:40-5:40 p.m.;
Tues. and Fri. 8:10-10:10 p.m.

6130 kc. TGXA
-B. 48.94 meters
GIORNAL LIBERAL PRO-
GRESSISTA, GAUTEMALA
CITY, GUAT.
Heard in the evening.

6130 kc. COCD
-B. 48.94 meters
"LA VOZ DEL AIRE"
CALLE G Y 25, VEDADO,
HAVANA, CUBA
Relays CMCD 11 a.m.-12 n., 7-
10 p.m., Sun. 12 n.-4 p.m.

6130 kc. VE9HX
-B. 48.94 meters
KUALA LUMPUR,
FED. MALAY STATES
Sun., Tues. and Fri.,
6:40-8:40 a.m.

6130 kc. HJ3ABX
-B. 49 meters
LA VOZ de COLOMBIA
CALLE 14, No. 738,
BOGOTA, COLOMBIA
5:45-11:30 p.m.

6120 kc. W2XE
-B. 49.02 meters
ATLANTIC BROADCASTING
CDRP.
485 MADISON AVE., N. Y. C.
Relays WABC, 11 p.m.-12 m.

6120 kc. XEFT
-B. 49.02 meters
AV. INDEPENDENCIA 28,
VERA CRUZ, MEX.
11 a.m.-4 p.m., 7:30 p.m.-12 m.
Sat. also 6:30-7:30 p.m.
Sun. 11 a.m.-4 p.m., 9 p.m.-12
m. Relays XETF

6115 kc.
-B. 49.05 meters
"RADIO PODEBRADY,"
CZECHOSLOVAKIA
Testing 2 p.m.-2 a.m.

6110 kc. VUC
-B. 49.1 meters
CALCUTTA, INDIA
Daily except Sat., 3-5:30 a. m.,
9:30 a. m.-noon;
Sat., 11:45 a. m.-3 p. m.

6105 kc. HJ4ABB
-B. 49.14 meters
MANIZALES, COL., S. A.
P. O. Box 175
Mon. to Fri. 12:15-1 p. m.;
Tues. & Fri. 7:30-10 p. m.;
Sun. 2:30-5 p. m.

6100 kc. W3XAL
-B. 49.18 meters
NATIONAL BROADCASTING
CO.
BOUND BROOK, N. J.
Relays WJZ
Monday, Wednesday, Saturday,
5-6 p.m., Sun. 12 m.-1 a.m.

6100 kc. W9XF
-B. 49.18 meters
NATL. BROAD. CO.
CHICAGO, ILL.
Tues., Thurs., Fri. 12 m.-
1 a.m., 8 p.m.-11:59 p.m.
M., W., Sat., 12 m.-1 a.m.
Relays WENR

6097 kc. ZTJ
-B. 49.2 meters
AFRICAN BROADCASTING
CO.
JOHANNESBURG, SOUTH
AFRICA.
Sun.-Fri. 11:45 p.m.
12:30 a.m. (next day)
Mon.-Sat. 3:30-7 a.m.
9 a.m.-4 p.m.
Sun. 8-10:15 a.m.; 12:30-3 p.m.

6092 kc. HJ4ABE
-B. 49.25 meters
MEDELLIN, COLO.
Daily 11 a.m.-12 n., 6-10:30
p.m.

6090 kc. CRXC
-B. 49.28 meters
TORONTO, CANADA
Daily 6:30 p.m.-12:30 a.m.
Sun. 12:45 p.m.-12:45 a.m.

6090 kc. VE9BJ
-B. 49.28 meters
SAINT JOHN, N. B., CAN.
7-8:30 p.m.

6085 kc. HJ5ABD
-B. 49.3 meters
"LA VOZ DE VALLE"
CALI, COLOMBIA
12 n.-1:30 p.m., 5:10-9:40 p.m.

6083 kc. VQ7LO
-B. 49.31 meters
NAIROBI, KENYA, AFRICA
Mon.-Fri. 5:45-6:15 a.m., 11:30
a.m.-2:30 p.m. Also 8:30-9:30
a.m. on Tues. and Thurs.; Sat.
11:30 a.m.-3:30 p.m.; Sun. 11
a.m.-2 p.m.

6080 kc. CP5
-B. 49.34 meters
LAFA, BOLIVIA
7-10:30 p.m.

6080 kc. HP5F
-B. 49.34 meters
CARLTON HOTEL
COLON, PANAMA
11:45 a.m.-1:15 pm., 7:45-10
p.m.

6080 kc. W9XAA
-B. 49.34 meters
CHICAGO FEDERATION OF
LABOR
CHICAGO, ILL.
Relays WCFL
Sunday 11:30 a.m.-9 p.m. and
Tues., Thurs., Sat., 4 p.m.-12 m.

6079 kc. DJM
-B.X. 49.34 meters
BROADCASTING HOUSE,
BERLIN, GERMANY

6072 kc. OER2
-B. 49.41 meters
VIENNA, AUSTRIA
9 a.m.-5 p.m., Sat. to 6 p.m.

6070 kc. YV7RMO
-B. 49.42 meters
MARACAIBO, VENEZUELA
6 p.m.-12 m.

6070 kc. HJ4ABC
-B. 49.42 meters
PERIERA, COL.
9-11 a.m., 7-8 or 9 p.m.

6070 kc. VE9CS
-B. 49.42 meters
VANCOUVER, B. C., CANADA
Sun. 1:45-9 p.m., 10:30 p.m.-
1 a.m.; Tues. 6-7:30 p.m.,
11:30 p.m.-1:30 a.m. Daily
6-7:30 p.m.

6065 kc. HJ4ABL
-B. 49.46 meters
MANIZALES, COL.
Daily 11 a.m.-12 n., 5:30-7:30
p.m., Sat. 5:30-10:30 p.m.

6060 kc. W8XAL
-B. 49.50 meters
CROSBY RADIO CORP.
CINCINNATI, OHIO
5:30 a.m.-8 p.m.; 11 p.m.-1 a.m.
Relays WLW

6060 kc. W3XAU
-B. 49.50 meters
PHILADELPHIA, PA.
Relays WCAU
8 p.m.-11 p.m.

6060 kc. OXY
-B. 49.50 meters
SKAMLEBOAEK, DENMARK
1-6:30 p.m.

6050 kc. HJ3ABD
-B. 49.59 meters
COLOMBIA BROADCASTING,
BOX 509, BOGOTA, COL.
12 n.-2 p.m., 7-11 p.m., Sun.
5-9 p.m.

6045 kc. HI9B
-B. 49.63 meters
SANTIAGO
DOM. REP.
Irregular 6 p.m.-11 p.m.

6042 kc. HJ1ABG
-B. 49.65 meters
EMISORA ATLANTICO
BARRANQUILLA, COLO.
11 a.m.- 11 p.m.
Sun. 11 a.m.- 8 p.m.

6040 kc. W4XB
-B. 49.67 meters
MIAMI BEACH, FLA.
Relays WIOD 12 n.-2 p.m.,
5:30 p.m.-12 m.

6040 kc. PRA8
-B. 49.67 meters
RADIO CLUB OF
PERNAMBUCO
PERNAMBUCO, BRAZIL
1-3 p.m., 4-7:30 p.m. daily

6040 kc. W1XAL
-B. 49.67 meters
BOSTON, MASS.
Tues., Thurs. 7:15-9:15 p.m.
Sun 5-7 p.m.

6040 kc. YDA
-B. 49.67 meters
N.I.R.O.M.
TANDJONGPRAK, JAVA
10:30 p.m.-2 a.m. Sat. 7:30 p.m.,
2 a.m. (Sun.)

6030 kc. HP5B
-B. 49.75 meters
P. O. BOX 910
PANAMA CITY, PAN.
12 n.-1 p.m., 7-10:30 p.m.

6030 kc. VE9CA
-B. 49.75 meters
CALGARY, ALBERTA, CAN.
Thurs. 9 a.m.-2 a.m. (Fri.);
Sun. 12 n.-12 m.
Irregularly on other days from
9 a.m.-12 m.

6025 kc. HJ1ABJ
-B. 49.79 meters
SANTA MARTA, COLO.
6:30-10:30 p.m. except Wed.

6020 kc. DJC
-B. 49.83 meters
BROADCASTING HOUSE,
BERLIN

6020 kc. XEUW
-B. 49.82 meters
AV. INDEPENDENCIA, 98,
VERA CRUZ, MEX.
8 p.m.-12:30 a.m.

6018 kc. ZHI
-B. 49.85 meters
RADIO SERVICE CO.,
20 ORCHARD RD.,
SINGAPORE, MALAYA
Mon., Wed. and Thurs 5:40-8:10
a.m. Sat. 10:40 p.m.-1:10 a.m.
(Sun.) Every other Sunday 5:10-
8:40 a.m.

6015 kc. HI3U
-B. 49.88 meters
SANTIAGO de los CABAL-
LEROS, DOM. REP.
10:40 a.m.-1:40 p.m., 4:40-
9:40 p.m.

6012 kc. HJ3ABH
-B. 49.91 meters
BOGOTA, COLO.
APARTADO 565
8-11 p.m.
Sun. 12 n.-2 p.m., 4-11 p.m.

6010 kc. COCO
-B. 49.92 meters
P.D. BOX 98
HAVANA, CUBA
Daily 9:30 a.m.-1 p.m., 4-7 p.m.,
8-10 p.m.
Sat. also 11:30 p.m.-2 a.m.

6005 kc. HP5K -B- 49.98 meters BOX 33, COLON, PANAMA 7:30-9 a.m., 12 n.-1 p.m., 6-9 p.m.	5950 kc. HJN -B- 50.42 meters BOGOTA, COL. 6-11 p.m.	5850 kc. ★YV5RMO -B- 51.28 meters CALLE REGISTRADO, LAS DE- LICIAS APARTADO de COR- RES 214 MARACAIBO, VENEZUELA 8:45-9:45 a.m., 11:15 a.m.-12:15 p.m., 4:45-9:45 p.m. Sun. 11:45 a.m.-12:45 p.m.	5713 kc. TGS -B- 52.51 meters GUATEMALA CITY, GUAT. Wed., Thurs. and Sun. 6-9 p.m.	4752 kc. WOO -C- 63.1 meters OCEAN GATE, N. J. Calls ships irregularly
6005 kc. ★CFCX -B- 49.96 meters CANADIAN MARCONI CO., MONTREAL, QUE., CAN. Relays CFCF 7 a.m.-12:15 a.m. Sun. 10 a.m.-11:15 p.m.	5940 kc. TG2X -B- 50.5 meters GUATEMALA CITY, GUAT. 4-6, 9-11 p.m., Sun. 2-5 a.m.	5830 kc. ★TIGPH -B- 51.5 meters ALMA TICA, APARTADO 800, SAN JOSE, COSTA RICA 11 a.m.-1 p.m., 6-10 p.m., Relays TIX 9-10 p.m.	5500 kc. TI5HH -B- 54.55 meters SAN RAMON, COSTA RICA Irregularly 3:30-4, 8-11:30 p.m.	4600 kc. HC2ET -B- 65.22 meters Apartado 249 GUAYAGUIL, ECUADOR Wed., Sat., 9:15-11 p.m.
6000 kc. HJ1ABC -B- 50 meters QUIBDO, COLOMBIA 5-6 p.m., Sun. 9-11 p.m.	5915 kc. HH2S -B- 50.72 meters PORT-au-PRINCE, HAITI BOX A103, 7:30-10:30 p.m.	5800 kc. ★YV2RC -B- 51.72 meters RADIO CARACAS CARACAS, VENEZUELA Sun. 8:30 a.m.-10:30 p.m., Daily 11 a.m.-1:30 p.m., 4-9:30 p.m.	5145 kc. PMY -B- 58.31 meters BANDONG, JAVA 5:30-11 a.m.	4320 kc. GDB -C- 69.44 meters RUGBY, ENGLAND Tests, 8-11 p.m.
5990 kc. ★XEBT -B- 50.08 meters MEXICO CITY, MEX. P. O. Box 79-44 8 a.m.-1 a.m.	5898 kc. YV8RB -B- 50.86 meters "LA VOZ de LARA" BARQUISIMETO, VENEZUELA 12 n.-1 p.m., 6-10 p.m.	5790 kc. JVU -C- 51.81 meters NAZAKI, JAPAN	5077 kc. WCN -C- 59.08 meters LAWRENCEVILLE, N. J. Phones England Irregularly	4273 kc. RV15 -B- 70.20 meters KHABAROVSK, SIBERIA, U. S. S. R. Daily, 3-9 a.m.
5988 kc. HJ2ABD -B- 50.10 meters BUCARAMANGA, COL. 11:30 a.m.-12:30 p.m., 5:30- 6:30, 7:30-10:30 p.m.	5885 kc. HCK -B- 50.98 meters QUITO, ECUADOR, S. A. 8-11 p.m.	5780 kc. OAX4D -B- 51.9 meters P. O. Box 833 LIMA, PERU Mon., Wed. & Sat. 9-11:30 a.m.	5025 kc. ZFA -C- 59.7 meters HAMILTON, BERMUDA Calls U.S.A., nights	4272 kc. WOO -C- 70.22 meters OCEAN GATE, N. J. Calls ships Irregularly
5980 kc. XEWI -B- 50.17 meters MEXICO CITY, MEX. Mon., Wed., Fri., 3-4 p.m. Tues., Fri. 7:30-8:45, 10 p.m.- 12 m.; Sat. 9-10 p.m.; Sun. 1- 2:15 p.m.	5875 kc. HRN -B- 51.06 meters TEGUCIGALPA, HONDURAS 1:15-2:15, 8:30-10 p.m., Sun. 3:30-5:30, 8:30-9:30 p.m.	5770 kc. HJ4ABD -B- 51.99 meters LA VOZ CATIA, MEDELLIN, COLOMBIA 8-11:30 p.m.	5000 kc. TFL -C- 60 meters REYKJAVIK, ICELAND Calls London at night. Also broadcasts Irregularly	4098 kc. WND -C- 73.21 meters HIALEAH, FLORIDA Calls Bahama Isles
5976 kc. HJ2ABC -B- 50.2 meters CUCUTA, COLOMBIA 6-9:30 p.m.	5865 kc. HI1J -B- 51.15 meters BOX 204, SAN PEDRO de MACORIS, DOM. REP. 12 n.-2, 6:30-9 p.m.	5720 kc. YV10RSC -B- 52.45 meters "LA VOZ de TACHIRA," SAN CRISTOBAL, VENEZUELA 6-11:30 p.m.	4975 kc. GBC -C- 60.30 meters RUGBY, ENGLAND Calls Ships, late at night	4002 kc. CT2AJ -B- 74.95 meters PONTA DELGADA, SAO MIGUEL, AZORES Wed. and Sat. 5-7 p.m.
5968 kc. HVJ -B- 50.27 meters VATICAN CITY 2-2:15 p.m., daily, Sun., 5-5:30 a. m.	5853 kc. WOB -C- 51.26 meters LAWRENCEVILLE, N. J. Calls Bermuda, nights		4820 kc. GDW -C- 62.24 meters RUGBY, ENGLAND Calls N.Y.C., late at night	3040 kc. YDA -B- 98.68 meters N.I.R.O.M. TANDJONGPURIK, JAVA Daily exc. Sat. 6-7:30 p.m., 5:30-10:30 or 11 a.m., Sat. 5:30- 11:30 a.m.

Alphabetical List of S-W Stations

By Call-Letter and Frequency

(Frequency in Megacycles)

CALL	FREQ.	CALL	FREQ.	CALL	FREQ.	CALL	FREQ.	CALL	FREQ.	CALL	FREQ.	CALL	FREQ.
CB960	9.06 mc.	GAD	19.48 mc.	HIX	6.13mc.	IAC	6.65 mc.	OXY	6.06 mc.	TYB	12.25 mc.	W3XAU	9.59 mc.
CEC	19.68	GAP	19.16	HIZ	6.32	IDU	13.39	PCJ	15.22	TYF	14.64	W3XAU	6.06
CEC	15.87	GAQ	18.97	HI1A	6.19	(I)2RO	11.81	PCJ	9.59	VE8BJ	6.09	W3XL	17.31
CEC	10.67	GAS	18.31	HI1J	5.86	ZRO	9.64	PCV	17.81	VE8BK	4.79	W4XB	6.04
CGA3	13.29	GAU	18.62	HI1S	6.42	JVE	15.66	PDK	10.41	VE8CA	6.03	W4XCA	31.60
CGA4	9.33	GAW	18.20	HI3C	6.10	JVF	15.62	PDV	12.06	VE8CS	6.07	W8XAL	6.06
CJA3	11.41	GBA	13.99	HI3D	6.02	JVH	14.60	PHI	12.06	VE8DR	6.01	W8XK	21.54
CJRO	6.15	GBB	13.59	HI4D	6.56	JVM	10.74	PHI	11.73	VE9HX	6.13	W8XK	15.21
CJRX	11.72	GBC	17.08	HI4V	6.48	JVN	10.66	PLE	18.83	VIZ3	11.56	W8XK	11.87
CNR	12.83	GBC	12.78	HI5N	6.14	JVP	7.51	PLV	11.50	VK2ME	9.59	W8XK	6.14
CNR	8.04	GBC	3.68	HI7P	6.80	JVT	6.75	PLV	9.42	VK3LR	9.58	W8XWJ	31.60
COCD	6.13	GBC	4.98	H18A	6.60	JVU	5.79	PMA	19.35	VK3ME	9.51	W9XAA	11.83
COCH	9.43	GBL	14.45	HI8B	6.05	JYK	13.61	PMC	18.14	VLJ	9.76	W9XAA	6.08
COCO	6.01	GBP	10.77	HJA3	14.94	JYR	7.88	PMH	11.5	VLK	10.52	W9XBS	6.43
COCQ	9.82	GBS	12.15	HJB	14.95	JYS	9.84	PMK	15.13	VLZ2	9.76	W9XF	6.10
COCQ	11.5	GBU	12.29	HJN	5.95	JYT	15.76	PMN	10.26	VPD	13.08	XBJQ	11.20
COKG	6.15	GBW	14.44	HJU	9.50	KAY	14.98	PMY	5.15	VPD2	9.54	XEBT	5.99
CO5JQ	8.67	GCA	9.71	HJ1ABB	9.56	KAZ	9.99	PNI	8.78	VP3MR	7.08	XECP	7.38
CO5WR	6.28	GCB	9.28	HJ1ABC	6.0	KEE	7.72	PPU	19.26	VQ7LO	6.08	XEFT	6.12
CP5	6.08	GCI	8.73	HJ1ABD	7.28	KEJ	9.01	PRADO	6.63	VRR4	11.60	XEME	8.19
CQN	9.59	GCI	13.42	HJ1ABE	9.50	KEL	6.86	PRAS	6.04	VUB	9.57	XEUW	6.02
CRCX	6.09	GCQ	8.76	HJ1ABG	6.04	KES	10.41	PRF5	9.50	VUC	6.11	XEVI	5.98
CSL	6.15	GCS	9.02	HJ1ABJ	6.03	KIO	11.68	PSA	21.08	VWY	8.98	XEXA	6.17
CT1AA	9.65	GCU	9.95	HJ1ABK	7.07	KKH	7.52	PSD	15.07	VWY2	17.51	XGM	17.65
CT1GO	12.40	GCW	9.79	HJ1ABP	9.62	KKR	15.46	PSF	14.96	WCN	5.08	XGOX	6.69
CT2AJ	4.00	GDB	4.32	HJ2ABA	6.18	KKZ	13.69	PSH	10.22	WKA	21.06	XGW	10.42
DAF	12.33	GDS	6.91	HJ2ABC	5.98	KTO	16.24	PSK	8.19	WKF	19.22	YBG	10.43
DAF	8.77	GDW	4.82	HJ2ABD	5.98	KWO	15.42	RIM	15.25	WKK	21.42	YDA	6.04
DFB	17.52	GSB	9.51	HJ3ABD	6.05	KWU	15.36	RIM	7.63	WKN	19.82	YDA	3.04
DGU	9.650	GSC	9.58	HJ3ABF	6.17	KWV	10.84	RIO	10.17	WLA	18.34	YDB	9.65
DJA	9.560	GSD	11.75	HJ3ABH	6.01	KWX	7.61	RIR	10.08	WLK	16.27	YDB	11.86
DJB	15.20	GSE	11.86	HJ3ABX	6.12	LKJ1	9.53	RKI	15.09	WMA	13.39	YNA	14.49
DJC	6.02	GSF	15.14	HJ4ABA	11.81	LKR	15.29	RKI	7.50	WMF	14.47	YNLF	9.65
DJD	11.77	GSJ	17.79	HJ4ABB	6.11	LRX	9.64	RNE	12.0	WMN	14.59	YVC	13.35
DJE	17.76	GSN	21.47	HJ4ABC	6.45	LSF	19.60	RV15	4.27	WNA	9.17	YVQ	6.67
DJL	15.11	GSO	15.26	HJ4ABD	6.07	LSG	19.90	RAN	9.60	WNB	10.68	YVR	18.30
DJM	6.08	GSJ	21.53	HJ4ABE	6.09	LSI	9.80	RW96	15.18	WNC	15.06	YVR	9.15
DJN	9.54	GSN	11.62	HJ4ABF	6.09	LSK3	10.25	SPW	13.64	WND	4.10	YV2RC	5.80
DJO	11.8	GSO	15.18	HJ4ABL	6.06	LSL	15.81	SUV	10.06	WOA	6.76	YV3RC	6.16
DJP	11.86	GSP	15.31	HJ4ABP	6.14	LSL2	10.30	SUX	7.86	WOB	5.85	YV4RC	6.38
DJQ	15.28	HAS3	15.37	HJ5ABD	6.09	LSM2	14.50	SUZ	13.82	WOF	14.47	YV5RMO	5.85
DJR	15.34	HAT4	9.13	HKB	9.93	LSN	9.89	TFJ	12.24	WOG	16.27	YV6RV	6.52
DZA	9.68	HBJ	14.54	HKE	7.10	LSN	14.53	TFK	9.06	WOK	10.55	YV7RMO	6.07
DZB	10.04	HBL	9.60	HKV	8.80	LSN5	19.65	TFL	5.0	WON	9.87	YV8RB	5.90
DZC	10.29	HBP	7.80	HPP	14.49	LSN6	21.02	TGF	14.49	WOO	17.62	YV9RC	6.40
DZE	12.13	HCETC	6.98	HPSB	6.03	LSX	10.35	TGS	5.71	WOO	12.84	YV10RSC	5.72
DZG	15.36	HCJB	8.95	HPSF	6.08	LSY	20.70	TGW	9.45	WOO	8.56	YV11RB	6.55
DZH	14.46	HCK	5.89	HPSJ	9.61	LSY3	18.12	TGXA	6.13	WOO	4.75	YV12RM	6.30
EAQ	9.86	HC2AT	8.40	HPSK	6.01	LZA	14.97	TG2X	5.94	WOO	4.27	ZBW	8.75
EDM	20.86	HC2ET	4.60	HRD	6.24	OAX4D	5.78	TIEP	6.71	WIXAL	15.25	ZFA	5.03
EDM	10.07	HC2JSB	7.85	HRF	14.49	OAX4G	6.23	TIGPH	5.83	WIXAL	11.79	ZFB	10.06
EHY	20.86	HC2RL	6.64	HR15	14.49	OCl	18.68	TIPG	6.41	WIXAL	6.04	ZGE	6.13
EHY	10.07	HC2TC	7.98	HRN	5.88	OCl	10.97	TIR	14.49	WIXK	9.57	ZHI	6.02
FTA	11.94	HH2S	5.92	HRP1	7.03	OCJ2	14.85	TIRCC	6.55	W2XAD	15.33	ZHJ	7.63
FTK	15.88	HH3W	9.60	HS8PJ	10.96	OE2R	6.07	TI4NRH	9.84	W2XAF	9.53	ZHT	7.39
FTM	19.36	HIG	6.28	HSJ	10.17	OLR	15.23	TI5HH	5.50	W2XE	21.52	ZLT2	7.39
FTO	18.25	HIH	6.78	HSP	17.74	OLR	11.76	TI6OW	6.85	W2XE	17.76	ZLT4	11.05
FZR3	16.23	HII	14.94	HVJ	15.12	OLR	6.12	TI8WS	7.55	W2XE	15.27	ZSS	18.89
FZS	18.35	HIL	6.50	HVJ	5.97	OPL	20.04	TPA2	15.25	W3XAL	17.78	ZTJ	6.10
FZS2	11.99	HIN	6.24	IAC	17.76	OPM	10.14	TPA3	11.88	W3XAL	6.12		
GAA	20.38	HIN	11.28	IAC	12.80	ORG	19.20	TPA4	11.72	W3XAL	17.78		
GAB	18.04	HIT	6.63	IAC	8.38	ORK	10.33	TYA	12.22	W3XAL	6.10		

Short Wave

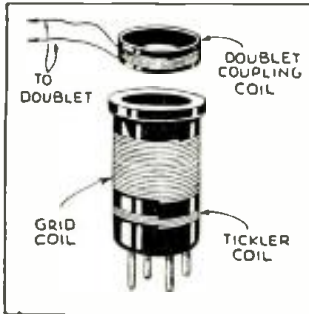

Doublet antenna coupling.

COUPLING DOUBLET TO S.W. RECEIVER

Jos. Redman, Buffalo, N.Y.

(Q) Will you please explain how a doublet antenna may be coupled to the "1935 Prof. Doerle"?

(A) The doublet should be connected to a small coil having 7 or 8 turns of wire the same diameter as the plug-in coil in the receiver. This coil should be coupled loosely to the grid coil. The coupling should be variable so that "dead spots" might be eliminated by loosening the coupling.

ing to be some hum in the earphones which cannot be eliminated.

TOO MUCH INTER-FERENCE

A Bodnar, Hopewell, New Jersey.

(Q) I have a 3-tube radio which gives satisfactory results except for the fact that I experience considerable interference in the broadcast band. For instance, WOR, WJZ, WABC, can be heard all at the same time. Could you please tell me how I might overcome this difficulty?

(A) In the first place, there is not enough inherent selectivity in a 3-tube set for operation on the broadcast band where powerful stations are operating. You might try using a short piece of wire only four or five feet long in place of the regular antenna. Remember that it takes a good superheterodyne to cope with the powerful local stations of the broadcast band.

LICENSE FOR 5 METERS?

Ed. Douglas, Cincinnati, Ohio

(Q) I am under the impression that a license is not needed for 5-meter transmission.

(A) As we have said over and over again, a license is necessary to operate any type of transmitter.

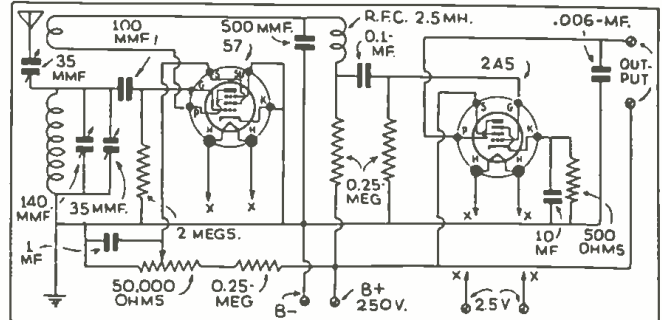

One of the most popular 2-tube pentode receivers.

satisfactory transformer. With condenser input in the filter, the transformer should be rated at about 400 volts and be capable of supplying around 200 milliamperes.

2-PENTODE BAND-SPREAD RECEIVER

John Sundstrom, Kansas City, Mo.

(Q) Please print the diagram of a 2-tube band-spread receiver employing pentode tubes, plug-in coils, and screen-grid regeneration control.

(A) The diagram shown illustrates a 57 pentode detector and a 2A5 pentode audio amplifier. This combination works out exceptionally well and is probably one of the most popular of the simple short-wave receivers. Band-spread is accomplished by connecting a 35 mmf. condenser in parallel with the main tuning condenser. Band-spread tuning is, of course, done with the smaller condenser.

HIDDEN MUSIC

Leslie Clay, Warwick, Mass.

(Q) I recently installed a well-known commercial receiver and find that when the speaker is disconnected the music can still be heard. Apparently this music is coming from one of the tubes. Can you give me a reasonable explanation of this unusual phenomenon?

(A) There is nothing unusual in your particular case. This may be caused by loose elements in the tubes, or some other part in the receiver which is carrying audio frequency current, and which are capable of vibrating such as loose laminations or windings in an audio transformer, or even a fixed condenser may be causing the program to be heard, even though the speaker is disconnected.

WHAT VOLTAGE?

J. Cadoane, Marshfield, Oregon.

(Q) Will you please tell me what the proper voltage would be for the plate of a 1-tube receiver employing a 6C5 tube?

(A) Normally, we would recommend about 45 volts on the plate. However, you may experiment with various voltages between 22½ and 45 in order to ascertain the particular voltage which will give the best results.

1 TUBER

Wm. Fuller, Pittsburgh, Penn.

(Q) In order to get started in short-wave reception, I would like to build a 1-tube receiver using plug-in coils. Would you kindly illustrate in the form of a diagram how the type 30 tube can be employed. This is to be operated from dry batteries.

(A) We have shown the diagram of a 1-tube receiver employing a type 30. This will serve as an excellent starter, inasmuch as one or two tubes may be added to it at any time in order to improve its performance.

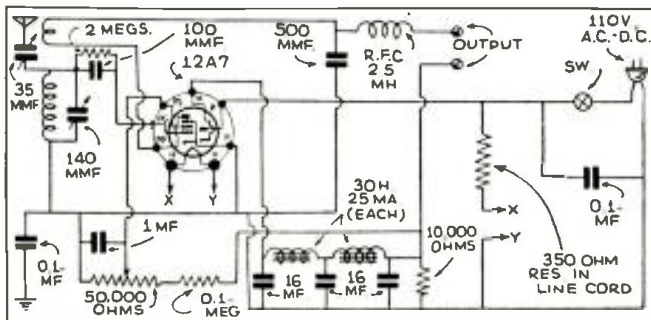

12A7 provides a 1-tube A.C.-D.C. receiver.

1-TUBE A.C.-D.C. SET

Arden Freer, Ancon, C.Z.

(Q) I would like to build a simple 1-tube receiver of the A.C.-D.C. variety and employing a 12A7 tube. I also desire to control regeneration with a 50,000 ohm potentiometer. I would appreciate it if you would publish the diagram in the Question Box.

(A) We have shown the diagram of the single 12A7 used as a rectifier and screen-grid detector, and excellent results may be obtained. However, there is most certainly go-

POWER SUPPLY FOR S.G.3 TRANSMITTER

John Walsh, Oak Lane, Phila., Penn.

(Q) I would like to have you print the diagram of a power-supply which could be used with the "S.G. 3" Transmitter described in a previous issue of Short Wave Craft. Kindly state where the power transformer may be purchased.

(A) We have shown a diagram of a power-supply suitable for the "S.G. 3" Transmitter and any reliable radio parts house can furnish a

ADDING AVC TO "H AND F SUPER"

Roy Woollacott, Rochester, N.Y.

(Q) I would like to know how automatic volume control (AVC) may be added to the "H and F Super" described in the March 1936 issue of Short Wave Craft. Will you please give the answer in your Question Box.

(A) It is not advisable to incorporate AVC in the "H and F Super." Its limit of operation will be so small that there will be no practical benefit, unless several tubes were added to the receiver.

RECEIVER FOR MOTOR-CYCLE

W. J. Rogers, Toronto, Ont., Canada.

(Q) I would like to know if I could get a diagram of a small short-wave receiver which could be operated on a motorcycle, so as to pick up police calls. It should not be too expensive or bulky.

(A) Any one of the many short-wave receivers described in past issues of Short Wave Craft may be used in conjunction with a motorcycle. However, we might add a word of warning—it is possible that local ordinances may prohibit the use of such a "police call" receiver. In the U.S. many municipalities have such laws and they probably exist in Canada as well.

It is well to look into this matter and avoid being lodged in the local hoosgow.

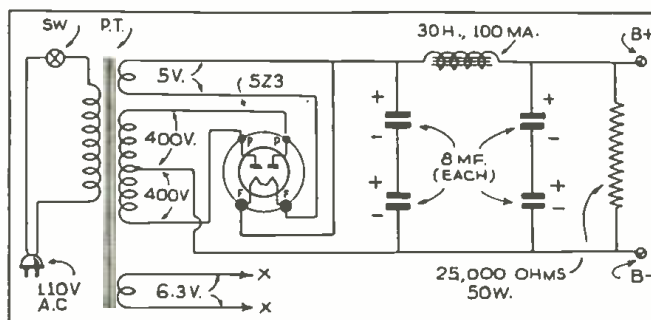

Power supply for the SG-3 transmitter.

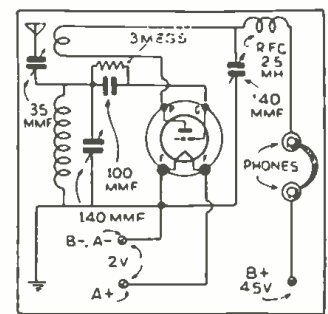

A 1-tube receiver using type 30.

QUESTION BOX

● Because the amount of work involved in the drawing of diagrams and the compilation of data, we are forced to charge 25c each for letters that are answered directly through the mail. This fee includes only hand-drawn schematic drawings. We cannot furnish "picture-layouts" or "full-sized" working drawings. Letters not accompanied by 25c will be answered in turn on this page. The 25c remittance may be made in

EDITED BY GEORGE W. SHUART, W2AMN

the form of stamps, coin or money order. Special problems involving considerable research will be quoted upon request. We cannot offer opinions as to the relative merits of commercial instruments. Correspondents are requested to write or print their names and addresses clearly. Hundreds of letters remain unanswered because of incomplete or illegible addresses.

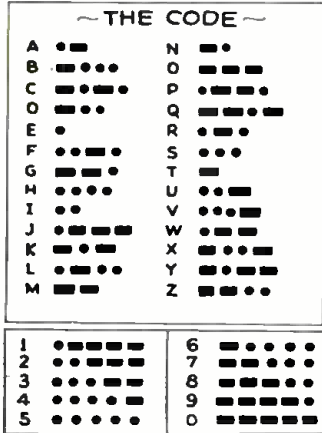

The radio code.

ceiver. However, we do not believe very good results will be obtained on 10 meters. The usual run of small receivers of the ordinary regenerative type do not perform well on the shorter wavelengths because it is difficult to make them stable.

3 EQUALS 4 RECEIVER

Fred Elias, Reedley, Calif.
 (Q) I would like to build an A.C.-D.C. receiver employing a 6F7, a 43, and a 25Z5. This receiver should be capable of operating a good magnetic speaker and operate on either A.C. or D.C. power lines.
 (A) In the diagram shown the 6F7 functions as a regenerative screen-grid detector with the regeneration controlled by varying the screen-grid voltage. The triode portion of the 6F7 serves as the first

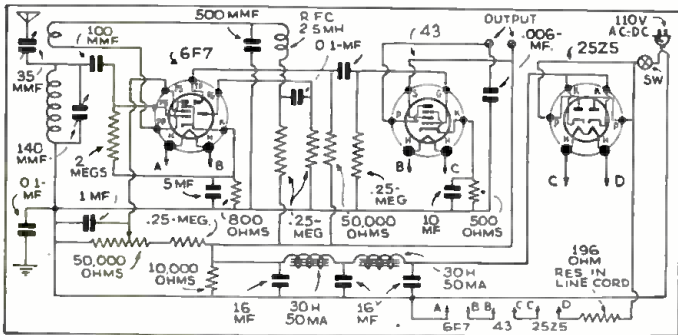

Combination "3 equals 4" receiver.

CODE ALPHABET

We have had many requests that the code be printed in the *Question Box*. Here is the complete alphabet as well as the numbers.

2-TUBE BATTERY SET

Fred Symthe, Biloxi, Miss.
 (Q) Please print in the short wave *Question Box* a diagram of an "all-wave" 2-tube receiver using two type 30 tubes. I would like to have this tuned down to 10 meters.
 (A) We have shown a diagram of a 2-tube battery-operated re-

audio amplifier and a 43 used in the output stage. This receiver will operate a magnetic speaker fairly well on signals of moderate strength.

GOOD BOOK FOR SERVICEMAN

Joe E. Walker, No. Belle Vernon, Penn.
 (Q) Would you kindly advise me on whether or not there is a book on the market that would be a guide to the radio repairman? I would like to obtain a book showing how to test transformers, condensers,

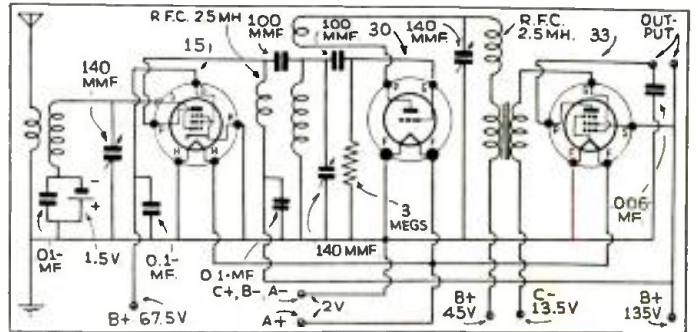

Employing the type 15 as an R.F. amplifier in a battery set.

and make general service repairs on various types of receivers.

(A) Recently there has appeared on the market a very complete book entitled, "Radio Serviceman's Handbook" by Joseph T. Burnley. A review on this book appeared in the November issue of *Short Wave Craft*. The book is published by Gernsback Publications.

DIAGRAM FOR "HRO"

Fred Utz, Redlands, Calif.
 (Q) Would you let me know whether or not you have published a diagram of the National "HRO" receiver and, if so, what issue did it appear in?
 (A) The complete diagram and technical description of the National "HRO" receiver appeared in the March, 1935 issue, page 664. Copies of this issue are still available at the regular price.

R. F. DETECTOR CIRCUIT

Conrad Fowler, Phila., Penn.
 (Q) Will you please print a diagram in the *Question Box* of a short-wave receiver having one stage of R.F. and a detector which could be employed with the audio amplifier which I already have. The tubes should be type 24 and 27. The power supply of the amplifier delivers approximately 150 volts.
 (A) We here show the diagram requested. However, we would suggest that you use a type 35 in the R. F. stage rather than the 24. "Band-spread" is also indicated and

is accomplished by connecting two 35 mmf. condensers in parallel with the large tuning condensers.

A GOOD BATTERY SET

Leo Knight, West Union, W.Va.
 (Q) I would like to have you print at your convenience, in the *Question Box*, a diagram of a 15 tuned R.F. amplifier, type 30 detector, and a 33 pentode audio amplifier. The set should use 4-prong plug-in coils and 140 mmf. tuning condensers.

(A) We have shown the diagram you request. A fixed bias of 1.5 volts is applied to the grid of the 15 R.F. amplifier. A single flashlight dry cell will serve satisfactorily as bias and last a long time. Regeneration in the detector stage is controlled by a variable condenser.

HOW TO GET VERIS

Andrew Stoker, Memphis, Tenn.
 (Q) I notice each month that a great number of *Short Wave Craft* readers submit a large total of verification cards for the Trophy Contest. I would like to know how to get these verification cards from the foreign short-wave stations.
 (A) Merely make a note of the time, date, and character of the program received and submit these to the station heard. Naturally, the stations require that you pay the postage and therefore it is necessary to include an International Postal Reply Coupon which may be obtained from your local post office.

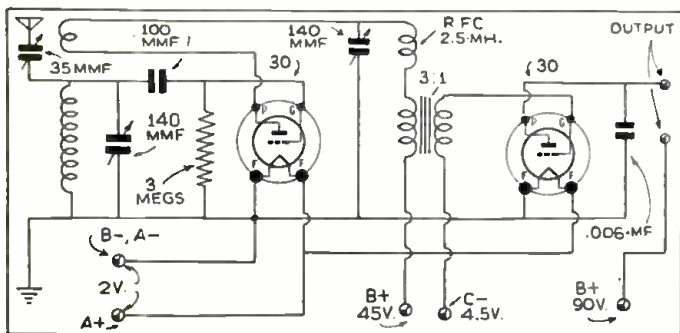

A 2-tube battery operated receiver.

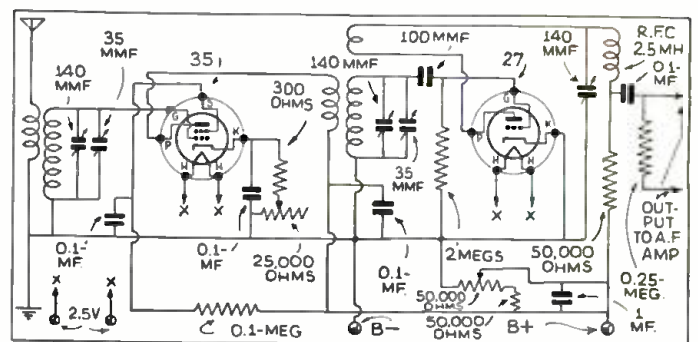

R.F. and detector stages for a short-wave receiver.

Here's Your Button

The illustration here-
with shows the beautiful
design of the "Official"
Short Wave League but-
ton, which is available to
everyone who becomes a
member of the Short
Wave League.



The requirements for
joining the League are
explained in a booklet, copies of which will
be mailed upon request. The button meas-
ures 3/4 inch in diameter and is inlaid in
enamel—3 colors—red, white, and blue.

Please note that you can order your but-
ton AT ONCE—SHORT WAVE LEAGUE
supplies it at cost, the price, including the
mailing, being 35 cents. A solid gold but-
ton is furnished for \$2.00 prepaid. Address
all communications to SHORT WAVE
LEAGUE, 99-101 Hudson St., New York.

HONORARY MEMBERS

- Dr. Lee de Forest
 - John L. Reinartz
 - D. E. Replogle
 - Hollis Baird
 - E. T. Somerset
 - Baron Manfred von Ardenne
 - Hugo Gernsback
- Executive Secretary*



SHORT WAVE
SCOUT
News

O. L. P. Report from Leetsdale, Pa.
● HERE is my monthly report. Reception
in general has been very good, in some
cases extraordinarily so. A few new ones
have been "logged" at this post.

AUGUST 26, 1936

COCX, in Havana, on 11,550 kc., 12:55 to
1:10 a.m. Music.

ZLT, Wellington, on 11,005 kc., 1:00 to
1:30 a.m., phoning London through VLK in
Sydney.

AUGUST 31, 1936

IAC, Pisa, Italy, on 12,865, from 2:30 to
3:00 p.m., phoning the ICEJ "Rex" (5R8).

COWR, Sancti Spiritus, on 6,280 kc.,
B.C. 11:50 to 12:00 midnight. QSA5R9;
static heavy.

SEPTEMBER 1, 1936

HJ5ABD, Culi, on 6,080 kc., from 12:00
to 12:08 a.m., requesting reports. Static;
QSA5R8-9.

HJ1ABG, in Barranquilla, on 6,040 kc.,
B.C. Special program to "Lions
(Club in U.S.)" 12:12 to 1:00 a.m.
QSA5R9 plus.

PMC, Bandoeng, Java, on 18,135
kc., 5:50 to 6:15 a.m., phoning Hol-
land. Rapid fading, QSA5R7.

TDE, in Manchukuo, on 10,060
kc., 6:15 to 7:00 a.m., phoning
Japan, QSA4R5-6.

PMH or PLH, Bandoeng, on 15-
140 kc., from 6:17 to 7:30 a.m.,
relaying N.I.R.O.M. program,
QSA5R6-7. This is a new station
and is heard now with PLP, 11,000
kc.

The Java station that was heard
some time ago on 11,500 kc. has
been verified as PMK. Not heard
at present, but instead PMH is
heard.

ZSS, Capetown, S. Africa, on
18,890 kc., 6:40 to 7:50 a.m.,
phoning London, QSA5R7-8.

VWY2, in Poona, India, on 17,480
kc., 7:50 to 8:02 a.m., phoning Lon-
don. QSA5R5-6; rapid fading.

OLR, Prague, Czech., on 15,230
kc., testing from 10:22 to 11:30
p.m. QSA4R6.

SEPTEMBER 2, 1936

HBF, in Geneva, on 18,455 kc.,
1:50 to 2:30 p.m., phoning New
York, QSA5R8-9. Also sending
music.

VPD-2, in Suva, Fiji Is., on 9,540
kc., 6:00 to 6:38 a.m. B.C. QSA5R6-
7. Rapid fading. They have
changed to this freq. Call now
VPD-2 and schedule 5:30 to 8:00
a.m. daily exc. Sun.

TI4NRH, in Heredia, C.R., on
9,670 kc., 9:40 to 10:00 p.m. B.C.
musical program; QSA4R6; static.
HIN, in Trujillo City, 11,290 kc.,

PMH, in Bandoeng, on 15,140 kc., 6:30
a.m. to 7:10 a.m., relaying NIROM pro-
gram.

VWY2, Poona, on 17,480 kc., 7:30 to 8:03
a.m., phoning London. QSA5R8.

SEPTEMBER 19, 1936

CLX, Havana, on approx. 7,005 kc., 11:50
to 11:55 p.m., phoning Canadian amateur
VE4JT. QSA5R9.

New verifications received are: IDU and
IRG. Here's address for IDU and IRG and
also for Italy's East African Stations:
Signor Carlo Matteini, Il Tenete Colonnello
A.N., Ministero della Marina, Derezione,
Centro R.T. Antonomo R. Marina, Rome,
Italy.

Others are: PMK, PLP, TYA-1, TYA-2,
FYC-2, YNLF, VK5LR, VK2MH, VK21Q,
VK2NY, VK4JX, VK3HL.

Lots of DX and 73.

SAMUEL SOLITO,
303 Beaver St.,
Leetsdale, Pa.

5:33 to 5:45 p.m. Musical program;
QSA5R7-8.

SEPTEMBER 5, 1936

XOJ, Shanghai, China, on 15,800 kc.,
12:40 to 2:00 a.m., calling and working
JVD, Tokio. QSA5R5-6.

SEPTEMBER 14, 1936

JIB, Formosa, on 10,530 kc., 5:00 to 5:45
a.m., phoning Japan. QSA5R7-8; slow
fading.

DJM, Berlin, 6,080 kc., 5:45 to 6:30 a.m.
B.C. QSA5R8. Static bad.

Official Listening Post Report of
F. W. Hartman, South
Amboy, N.J.

● AMONG the stations heard the
past month were: (E.S.T. used
throughout).

CFCX—Montreal, Can.—6005 kc.
—Heard as per schedule in *Short
Wave Craft*.

HIT—Ciudad Trujillo, D.R.—
6630 kc.—Heard as per schedule in
Short Wave Craft.

DJD—Berlin, Germany—11770
kc.—Heard as per your schedule.

DJA—Berlin, Germany—9560 kc.
—Heard as per "S.W.C." schedule.

DJN—Berlin, Germany—9540 kc.
—Heard as per "S.W.C." schedule.

COCO—Havana, Cuba—6010 kc.
—Heard on Aug. 20th at 9 p.m.
Good.

2RO—Rome, Italy—11810 kc.—
Heard nights between 5 and 7 p.m.

DJB—Berlin, Germany—15200
kc.—Heard after 6 p.m.

GSD—Daventry, England—11750
kc.—Heard as per "S.W.C." sched-
ule.

PCJ—Eindhoven, Holland—9590
kc.—Heard as per "S.W.C." sched-
ule.

RNE—Moscow, U.S.S.R.—12,000
kc.—4 to 5 p.m. on Sunday, Mon-
day, Wednesday, and Fridays.

RAN—Moscow, U.S.S.R.—9600
kc.—Daily 7 to 7:30 p.m.

HIN—La Voz Del Partido Domi-
nicano., Ciudad Trujillo, D.R.—
BROADCASTS on BOTH 11,280 kc.
and on 6243 kc.—Daily 7:10 to 9:10
p.m.

FLETCHER W. HARTMAN,
365 John Street,
South Amboy, N.J.

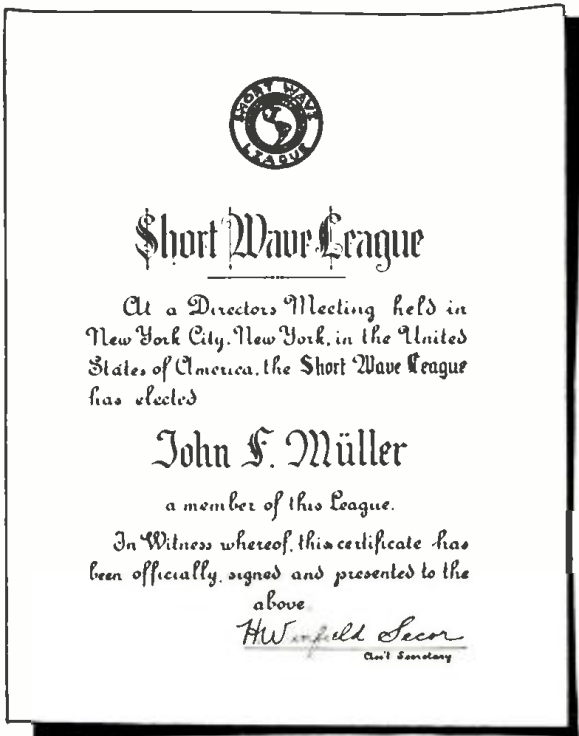

This is the handsome certificate that is presented
FREE to all members of the SHORT WAVE
LEAGUE. The full size is 7 1/4"x9 1/2".

"NEW 1937 SHORT WAVE APPARATUS—THE IDEAL CHRISTMAS GIFT"

(Guaranteed shipment of all orders within 24 hrs.)

EILEN RX-17 7-tube BANDSPREAD RECEIVER
(8½ to 3,000 meters)

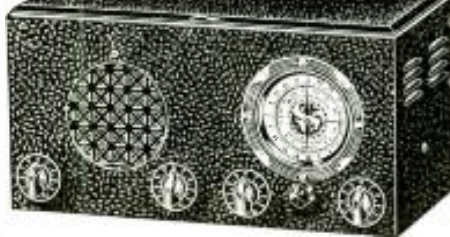

Our largest, finest, and most sensitive new 1937 receiver, unequalled in appearance, performance and value. Uses a special, highly efficient and selective circuit producing results which WILL satisfy even the most discriminating short wave fan.

Constructed of the finest materials and in conformity with the highest engineering standards, this instrument uses two 410s, two 635s, one 76, one 12, and one 533 high gain tubes as **TUNED RF AMPLIFIER, TUNED ELECTRON COUPLED SCREEN-GRID REGENERATIVE DETECTOR**, powerful 3 stage audio frequency amplifier with power pentode output stage delivering 3 watts of audio power to the built-in high fidelity dynamic loudspeaker. **VARIABLE NOISE SUPPRESSOR**, together and complete built-in **HUM-FREE** power supply. **BANDSPREAD TUNING**—a special electron tube circuit enabling the operator to reduce or eliminate certain types of noises occurring in all short wave receivers—automatic headphone jack—smooth and noiseless control—highly efficient interchangeable type vernier dial—sensitivity, volume, and selectivity that will amaze you—are features to be found in RX-17.

RX-17, complete, READY TO USE, with 7 RCA or Sylvania tubes, 8 low-loss silver plated coils for 8½ to 200 meters, wired, in cabinet, and 7 page instruction booklet..... **\$45**
Broadband coils (200-500 meters) extra..... **\$1.25**
(If metal tubes are preferred over the glass type, add \$1 to above price.)

\$21.95

For those who wish to build their own we offer:
KIT of all parts, coils for 8½-200 mc., less tubes & cabinet..... \$13.95
Cabinet, extra..... **\$2.50**
5 matched Sylvania tubes extra..... **\$3.25**
Long wave coils (550-1,000 meters)..... **1.95**

AMATEURS: Model RX-17-AB has same specifications as RX 17 except that it is equipped with plate voltage cut-off switch and special bandspread coils for 20-40-80-160 M bands spreading these bands 80% of dial scale. Add \$1 to price of RX-17. (10 meter band coils if desired extra \$1.45).



Eilen "MULTI-WAVE" DeLuxe 6 Tube Regenerator
2½ to 3,000 Meters

A startling new development in short wave receivers. Now, for the first time, the short wave fan is offered a really efficient, sensitive, and compact receiver covering all wavelengths between 2½ and 3,000 meters, using the highly efficient interchangeable inductor system. **BANDSPREAD TUNING** on all wavelengths. Signals from all parts of the world—powerful transatlantic and ship long wave stations—regular broadcast land stations—police calls, amateurs, experimental and regular foreign as well as domestic short wave transmissions AND the newly developed 2½ to 10 meter region with its host of amateur television, and experimental stations—all roar in with great loudspeaker volume and remarkable regularity. The multi-wave regenerator has been designed so as to be extremely simple in operation. Even the beginner can operate it to complete satisfaction.

USES SIX of the high gain type of tubes—(410, 76, 70, 71, 42, 63) as high gain RF amplifier, electron coupled regenerative detector, **POWERFUL** two stage hi-fidelity audio frequency amplifier with pentode output stage delivering 3 watts of audio power to the built-in hi-fidelity dynamic speaker, full wave rectifier and built-in **HUM-FREE** power supply. Operates entirely from your AC 105 to 130 volt AC house current. On wavelengths below 15 meters, the extremely sensitive super-regenerative principle is automatically employed. This unit makes an ideal amateur communications receiver. Entire unit is finished in beautiful chrome plated chassis and black shirvel finished metal cabinet. Illuminated airplane type vernier dial.

EILEN "MULTI-WAVE" REGENERATOR, WIRED, COMPLETE, READY TO USE, including cabinet, 6 matched RCA tubes, 6 coils for 2½ to 200 meters, and simple instructions, less extra coils..... **\$19.95**
(1) Broadband band coils, 200-500 meters, extra..... **\$1.25**
(2) Long wave coils, 600-1000 meters, extra..... **\$1.45**
SPECIAL: EILEN MULTI-WAVE REGENERATOR KIT, cabinet, coils for 2½ to 200 meters, speaker, and simple instructions, less tubes, unwired..... \$14.95
Wired..... **\$2.00**
Set of 6 matched RCA tubes, extra..... **\$2.90**
If metal tubes are desired, add \$1 to above prices.



Eilen BS-5 6-Tube Band Switch Receiver
12 to 600 meters

A powerful, sensitive, and selective SW receiver covering the entire wave-length span of 12 to 600 meters in 12 steps. NO 114 G-I N COILS are used. Simply turn the waveband selector switch and enjoy reception on any wavelength within this range.



Uses two 410s, one 76, one 13, one K12A, and one 25Z5 tubes as RF amplifier, electron coupled screen grid regenerative detector, powerful 2 stage audio amplifier with pentode output stage, rectifier, and complete built-in power supply.

HUM-FREE hi-fidelity dynamic loudspeaker—illuminated, airplane type vernier dial—band spread tuning control—automatic headphone jack—extremely smooth setting controls—operates from your AC or DC house current—beautiful heavy, black shirvel finish chassis and cabinet.

DELIVERS GREAT LOUDSPEAKER VOLUME ON THE GREAT MAJORITY OF SHORT WAVE FOREIGN STATIONS UNDER FAIR CONDITIONS.
PRICE, complete with 6 tubes, cabinet, wired, ready to use..... **\$16.95**

AMATEURS: Model BS-5-AB has same specifications as BS-5 except that it has special bandspread circuit for 20-40-80-160 M bands and is equipped with plate voltage cut-off switch. Add \$1.00 to above price.

BS-5 KIT, of necessary parts, including detailed instructions, less tubes, cabinet, unwired..... \$10.95
SPECIAL: Complete kit, cabinet, tubes and instructions, unwired (if metal tubes are preferred to glass type, add \$1)..... \$14.95

Eilen 7C 5-Tube Short Wave Receiver
8½ to 625 meters



Bigger and More Powerful Than Ever A Giant in Performance



3-Tube Short Wave Radio
Only \$3.25
(less tubes, phones, unwired)

A REAL, powerful 3 tube short wave set that readily brings in amateurs, police calls, broadcast stations, experimental and foreign stations with good volume under fair conditions. **THE WORLD AT YOUR DOOR!**

THREE TUBE BATTERY SET, less tubes, phones, unwired \$2.95
TWO TUBE BATTERY SET, less tubes, phones, unwired \$2.00

FULL 6 TUBE PERFORMANCE plus THE NEW K92A SERIES TUBE makes this an outstanding value. Equipped with a powerful 3 stage audio frequency amplifier. Uses 616-6F7 (twin 2 in 1 tube)—7C—K92A-12A7 (twin tube tubes as RF amplifier, screen grid regenerative detector, powerful 3 stage audio amplifier with pentode output stage, rectifier and complete built-in power supply. Operates entirely from 105 to 130 volt AC or DC light socket.

EILEN 7C RECEIVER, wired, in cabinet, complete, READY TO USE, with speaker, 5 RCA tubes, 6 coils for 8½ to 625 meters, and simple instructions..... **\$14.20**
7C KIT, unwired, of necessary parts, 4 coils for 8½ to 200 meters, and instructions, less cabinet, speaker, tubes..... \$7.25
Beautiful metal cabinet, extra..... **\$1.25**
5 matched RCA tubes..... **3.15**
Special loudspeaker..... **1.45**
(2) Broadband band coils, 200-625 meters..... **1.45**
Labor for wiring & testing, extra..... **1.50**
SPECIAL: COMPLETE KIT, unwired, cabinet, 5 tubes, speaker, 6 coils for 8½ to 625 meters, and simple instructions..... \$12.75

AMATEURS: Model 7C-AB, same specifications as 7C except that has special tuning circuit and coils for spreading out the 20-40-80-160 M bands over 80% of dial. Also equipped with plate voltage cut-off switch. Same price as 7C. Model 6B or 6B-AB battery model at 7C. Operates from inexpensive dry batteries. Same price.

A dependable receiver which is guaranteed to give results. Operates entirely from the AC or DC house current. Simple to build and easy to operate. Beautiful, black shirvel finish cabinet and 14 tubes furnished. Wave-length range 12-600 meters. An ideal set for the beginner who wishes to learn the thrill of short wave reception.



Eilen AN-5 Four Tube BANDSPREAD RECEIVER

A powerful and highly selective short wave receiver designed for the fan who prefers the use of headphones. Uses 617-410B, 4-81 tubes in five-tube per-tubeance circuit. Tuned electron coupled screen grid regenerative detector, two stage audio amplifier, rectifier. A built-in power supply. **HUM-FREE, POWERFUL**. Operates from your 105-130 volt AC house current.

AN-5, complete with 4 matched tubes, coils for 9 to 200 meters, cabinet, wired..... \$15.95
READY FOR USE..... \$1.45
Broadband band coils (2), extra..... **\$1.45**
AMATEURS: Model AN-5-AB has same specifications as AN-5 except that has plate voltage cut-off switch and special bandspread coils for 20-40-80-160 meter bands. Add \$1 to price of AN-5.

Eilen HF-35 3-Tube SW Transmitter

A powerful and well engineered amateur band transmitter of great beauty and efficiency—**AT A PRICE WITHIN THE AMATEUR'S REACH**. Uses 50-46-46 tubes as TRITET CRYSTAL CONTROLLED OSCILLATOR—CLASS C RF POWER AMPLIFIER—built-in antenna tuning system—beautiful, black shirvel metal case and shielding—Triplet meters—Eilen transmitting dials—highest quality construction. 35 watts of power output on 20-40-80-160 M bands. A transmitter that you can be proud to own. An excellent exciter unit for high power stages to be added later. 3 coils for any 1 band and instructions included.



HF-35, assembled, and ready to wire (less tubes, power supply, crystal, holder and additional coils)..... \$21.95
Matched Arcturus Tubes (410, 160)..... **\$2.15**
Eilen quartz crystal (80 or 160)..... **1.00**
Eilen crystal holder..... **1.00**
Coils for additional bands, per set..... **1.45**

HV-475 1-Tube power supply for use with HF-35, less tube..... \$12.95
Labor for wiring extra..... **\$1.00**
83 tube for HV-475, extra 65 cents

M-15 3-Tube Modulator for use with HF-35 and capable of modulating its entire output at 100%, priced at (less tubes)..... \$14.95
Three Arcturus tubes, 50-53-53, extra..... **\$1.95**

FREE: New 1937 catalogue

of short wave receivers, transmitters, & 5 meter apparatus. Send stamp to cover mailing costs on YOUR copy.

JUST OFF THE PRESS!
Prompt service, 20% deposit on C. O. D. orders

Featuring—THE ACE "UNIVERSAL-SIX" AC-DC-BATTERY FOUR TUBE RECEIVER

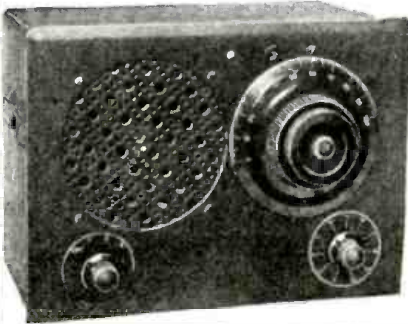

ACE UNIVERSAL-SIX \$1275
receiver with four tubes, cabinet, all coils, and built-in speaker. COMPLETE, nothing else to buy. Not wired.

Laboratory wired and tested, complete, ready to plug in. \$14.50

NOTE: If tubes, speaker, Broadcast Band coils, and cabinet are not desired at present you may deduct from the above prices \$550

IMAGINE! A compact, self contained, sensitive receiver with real **SIX TUBE** performance that will operate on any AC or DC house line. Simply plug in a cable and—**PRESTO!**—a completely battery operated set that you can use in your car, boat, or any other place! The same full toned loud speaker volume—the same thrilling foreign reception—the same ease of operation! No changes in wiring. Really **TWO** receivers for less than you would expect to pay for only one!

Look at this powerful tube line-up: Screen grid pentode RF stage—electron coupled regenerative detector—THREE STAGE high quality audio amplification with power pentode output—heater type rectifier and humless power supply. **FULL SIX TUBE POWER** from two dual "Twin" 6F7 tubes and heavy duty 38 and 1-V tubes!

And these features: Full bandspread 9½ to 625 meters—self contained, good quality loud speaker—New Transmitter type tuning dial with dual speed friction drive—Provision for headphones—Indirect panel illumination—Velvet smooth control of regeneration—operates entirely from any AC or DC house socket **OR ON BATTERIES** (storage battery, or four dry cells, and three small B batteries). Low current drain means long, economical life of tubes and batteries.

This receiver is easy to build—easy to operate—and it certainly pulls 'em in! Order your Universal Six now! You will be amazed at the full loud speaker volume of distant stations! Every set is fully guaranteed. Buy with safety!

And—The Ace Do-all DeLuxe

2½ TO 3000 METERS

FULL BAND-SPREAD



SEVEN TUBE
● TUNED R.F. STAGE
● NOISE SUPPRESSOR

LOOK AT THESE FEATURES:—

- **TUBE LINE-UP:** 6K7 (all metal) tuned high gain i-f-selector stage—6K7 electron coupled regenerative detector—76 T. H. P. 2½ to 10 meter Super-regenerative detector—76-76-43 High Fidelity THREE STAGE audio frequency amplifier with three watts actual output—5Y4G Full-wave, high voltage full power rectifier. **TOTAL—SEVEN FULL DUTY TUBES!!**
- **TUNED RADIO FREQUENCY STAGE**—A positive essential for sharp selectivity.
- **RANGE:** 100 Ke to 120 Mc. Continuous—no skips!
- **DUPLEX REGENERATION CONTROL:** Semi-Automatic keeps detector action at peak sensitivity—manual control for setting.
- **FULL BANDSPREAD:** Two new Transmitter type dials with built-in dual speed friction drive give positive, velvet smooth control and full spread of all bands.

● **NOISE SUPPRESSOR:** Built-in, switch controlled device markedly decreases interfering noises.

● **AND—Self-contained,** (all floating high fidelity dynamic speaker—Single wire or double antenna input—R.F. gain control—Headphone Jack with automatic speaker cut-out—Built-in power supply. Humless high voltage type for AC operation only—Calibration curves mounted on front panel—Smart, professional satin aluminum finish—Provision for standard 8½" x 19" relay rack mounting—All metal tubes in R.F. circuits give complete shielding and greater sensitivity. (All glass tubes, if preferred, supplied at same prices)—Dual indirect panel illumination—Attractively finished, durable cabinet for table or rack mount—Extreme simplicity of operation—SIX page instruction, diagram, and tuning booklet—etc., etc.

This is the famous Do-All DeLuxe Receiver that has amazed the entire Short Wave World by its remarkable performance! With this receiver in your "shack" watch your DX catches, QSO's, and your veries grow by leaps and bounds. Other set owners simply have to take a back seat!

The Do-All DeLuxe is new! It's different! It's better! And—it costs less!

The Do-all DeLuxe is the only receiver that incorporates all of these important advancements toward better, easier, **POSITIVE RECEPTION OF FOREIGN BROADCAST!**

This is the receiver that will **DO-ALL—** and more—than higher priced sets can do.

It is honestly the best value ever offered to the Short Wave Fan and the Amateur! Order yours today and be convinced!

DO-ALL DELUXE STANDARD MODEL (9 to 3000 Meters)
Six tube Receiver, complete with matched tubes, and cabinet. Nothing else to buy! (Not wired) \$1975

Laboratory wired and tested. Ready for you to attach antenna, plug into socket, and thrill to new and strange programmes! Price \$2175

If tubes, cabinet, and 200 to 3000 meter wavelength range are not desired at present you may deduct from the above prices \$500

DO-ALL DELUXE ULTRA MODEL (2½ to 3000 Meters)
Seven tube Receiver, complete with matched tubes and cabinet. Ready to be wired. \$2375

Laboratory wired and tested, ready to operate. The entire world of Radio at your command! Complete \$2625

If tubes, cabinet, and 200 to 3000 meter wavelength range are not desired at present you may deduct from the above prices \$500

• Literature on Request •

ACE RADIO LABORATORIES
70 Barclay St., Dept. C-12, New York City

"Universal" Receiver

(Continued from page 472)

duce the overall size and weight of the receiver. Two 6F7's displace the four tubes needed for R.F., detector, First and Second A.F.

Thus we achieve full six tube performance from only four tubes.

About the performance of any set much can be said, but the "proof of the Dx-ing is in the tuning." There is something almost uncanny about the ease with which even the most hard-to-get foreigners roll in—full speaker volume on most!

The speaker impedance should be at least 7,000 ohms, to match the pentode output tube.

The 12 to 1 ratio dial gives a surprisingly fine bandspread.

It should be noticed that the chassis is connected in the circuit only through a fixed condenser. The circuit of this receiver is so designed that shocks are impossible. Touching the set and a ground will produce no disastrous results.

While on the subject of grounds it will be found that one is not essential for operation of this set. Results seemed to be almost the same with or without a ground.

Now for the "universal feature." You've probably wondered what the 6-prong socket on the rear of the chassis is for. Well, it takes the place of a more expensive switch which would be needed to connect the tube heaters in parallel for battery operation. This is accomplished by inserting a 6-prong plug into the socket which has the proper jumper (wire) connections—the leads to the batteries are also attached to this plug making it possible to detach the cable and batteries in a jiffy. Plate potential should be 135 volts, obtainable from three 45 volt "B" Batteries connected in series.

The heater current may be supplied by a 6-volt storage battery or four dry cells connected in series. Here again the drain is low, being only .9 ampere. The same switch on the panel controls the battery circuit as well as the A.C.-D.C. power.

The jumper connections in the plug are clearly shown in Fig. 2. When operating on batteries the A.C. plug should not be in the socket!

A series of five coils is used to cover the range of 9½ to 625 meters, or 480 kc. to 32 megacycles. The forms should be of bakelite or other low-loss material. They are the ribbed type having a winding diameter of 1½ inches. The primary, or plate winding, is at the bottom. The grid winding starts with the ground end, up to the cathode tap, and continues up to the grid end at the top.

COIL TABLE

RANGE		PRIMARY	
METERS	MEGACYCLES	(Close-wound)	
9½ - 15	20 - 32	2½ No. 27 Enam.	
13½ - 36½	8.2 - 22.2	5½ No. 27 Enam.	
32½ - 89	3.3 - 9.25	9½ No. 27 Enam.	
80 - 225	1.35 - 3.75	20½ No. 30 DSC	
220 - 625	.48 - 1.36	28½ No. 34 Enam.	
SECONDARY		Space	CATHODE
Turns	Wire	between turns	TAP AT
4½	No. 18 Tinned	1/8"	1/4" T
9½	No. 22 Tinned	1/8"	2/4" T
24½	No. 27 Enam.	1/8"	2 1/4" T
51½	No. 30 DSC	Close	2 3/4" T
158½	No. 34 Enam.	Close	3 1/4" T

Parts List

- 1—"Fyaur" Vernier Dial
- 2—Knobs
- 1—.00014 mf. Variable Condenser
- 1—350 ohm line dropping cord
- 2—6 prong wafer sockets
- 2—7 prong wafer sockets
- 1—5 prong wafer socket
- 1—4 prong wafer socket
- 1—50,000 ohm potentiometer
- 1—Filter condenser block
 - 12 Mf.—200 Volt
 - 12 Mf.—200 Volt
 - 5 Mf.—35 Volt
- 1—Twin Jack for speaker or Headphones
- 5—Coils (See Text)
- 12—½ Watt Resistors (Values given in diagram)
- 5—Mica Condensers (Values given in diagram)
- 7—.01 200 Volt Tubular Condensers
- 1—.25 Mf. 200 Volt Tubular Condenser
- 1—150 ohm midget Filter Choke
- 1—Rotary snap switch
- 1—Loudspeaker (see text)
- 1—3 Amp Pilot light bulb and socket
- 1—Chassis and Panel—Ace U-6
- Miscellaneous hardware, grid clips, ties, etc.

Please mention SHORT WAVE CRAFT when writing advertisers

GET ACQUAINTED WITH OUR 1937 LINE

Consisting of 15 models, to fit the needs of EVERY SHORT WAVE FAN!
 Made in TWO AND THREE BANDS from 15 TO 2,000 METERS, priced from
 \$17.95 to \$95.00

EACH MODEL IS AN OUTSTANDING VALUE

DEWALD

THE INTERNATIONALLY KNOWN RECEIVER



MODEL 518

- 5 Tube Universal Hi-Gain T.R.F. Receiver.
- 2 Bands—75-550 Meters.
- Full Range Dynamic Speaker.
- Duo-colored Aeroplane Dial.
- Incorporating metal tube.
- Broadcast & American short wave. \$18.90



MODEL 520

- 5 Tube A.C. Superheterodyne Receiver.
- 2 Bands—70-190, 190-555 Meters.
- Duo-colored Aeroplane Dial.
- Full Range Dynamic Speaker.
- Broadcast & American short wave\$26.55



MODEL 619

- 6 Tube Universal Superheterodyne Receiver.
- 2 Bands—75-550 Meters.
- Full Range Dynamic Speaker.
- Large Duo-colored Aeroplane Dial.
- Incorporating metal tube.
- Broadcast & American short wave. \$27.50

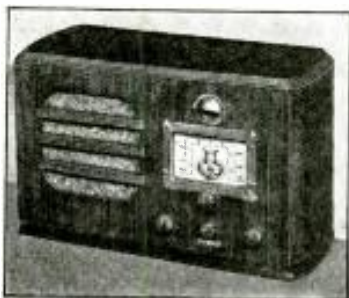

MODEL 620

- 6 Tube A.C. Superheterodyne Receiver.
- 2 Bands—18-52, 180-555 Meters.
- Tone Control.
- Magic Eye.
- Large Duo-colored Aeroplane Dial.
- Full Range Dynamic Speaker.
- Broadcast & Foreign short wave. \$35.75



MODEL 618

- 6 Tube Universal Superheterodyne Receiver.
- 3 Bands—18-52, 16-190, 180-555 Meters.
- All Wave.
- Tone Control.
- Large Duo-colored Aeroplane Dial.
- Incorporating metal tube.
- Full Range Dynamic Speaker.
- Broadcast, American & Foreign short wave \$37.25



MODEL 622

- 6 Tube Universal Superheterodyne Receiver.
- Large Duo-Colored Aeroplane Dial.
- Full Range Electro-Dynamic Speaker.
- Incorporating Metal Tube.
- Broadcast and State Police Calls.
- 180-550 Meters..... \$25.75

Above Prices Complete, including tubes, speaker and cabinet

FREE Send for our COMPLETE CATALOG. YOU ARE SURE TO FIND A MODEL TO SUIT YOUR NEEDS. If your dealer does not have a DeWald in stock and will not order one for you, please write to us and we will have a dealer near you supply your wants.

JOBBERS We are building up a ready made business for you. THOUSANDS of DeWald sets will be sold. Get your share of our inquiries and TURN THEM INTO ORDERS.

WRITE, WIRE or TELEPHONE for our proposition—YOU WILL FIND IT PROFITABLE

Quality radios since 1921

PIERCE-AIRO INC.

Dept. 12,

New York, N. Y.

510-518 Sixth Avenue

Licensed by R. C. A. and its affiliates.

Please mention SHORT WAVE CRAFT when writing advertisers

Is Your Power Supply

* HÆMOPHILIAC?

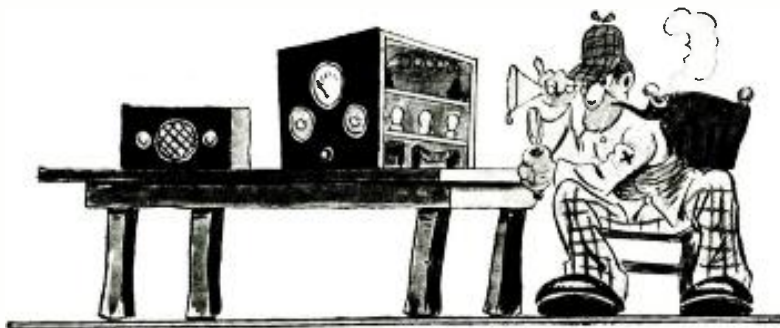

**A Power Supply utilizing bleeders dissipating wasteful and costly wattage in order to obtain correct operating potentials thereby reducing efficiency and impairing load regulation.*

Before modernizing your present equipment or buying a new plate transformer why not get the dope on our new exclusive triple winding plate transformer and compare it on merit alone with others. This new exclusive triple winding plate transformer provides the utmost in flexibility. Over 30 different voltages are available ranging from 400 to 3,000 volts. Regardless of revolutionary overnight changes in radio, this unit will never become obsolete. Applicable to over ten different rectifier circuits. The most versatile transformer ever manufactured.

Low In Price Yet Built To Stand The Gaff

KENYON manufactures, in addition, a complete line of quality audio products that defy competition both as to quality and price.

Ask your local dealer for a free copy of the first issue of the new 16 page monthly magazine "THE KENYON ENGINEERING NEWS."

Our new transmitting manual contains complete up-to-date transmitter circuits ranging in size from five watts to one kilowatt. The new triple winding plate transformer is utilized to full advantage in many of these circuits. This not only provides better regulation but considerably lowers the cost. Ten pages are entirely devoted to full page "Ken-O-Grafs" which cover most of the calculations used in radio in a modern and painless method. This book is no subterfuge for a catalog. To receive your copy send 25 cents in coin or stamps.

Address your inquiries to Chief Engineer, Radio Section

KENYON TRANSFORMER CO., INC.

840 Barry St.,

New York, N. Y.

Are You a Subscriber? See Pages 512 and 517 for Remarkable Subscription Offers.

RECEIVERS

- HALLICRAFTERS • HAMMARLUND • SARGENT • RCA •
- RME-69 • PATTERSON • BRETING • NATIONAL • PILOT •
- PHILCO • CROSLY • GENERAL ELECTRIC • ETC. •

Most complete stock of all Amateur and Short Wave Equipment
 PROMPT SERVICE—TIME PAYMENT PLAN—TRADE-INS—LOWEST PRICES
 WRITE FOR INFORMATION OR COME TO THE FRIENDLY HAM STORE

Open 9 to 7 daily

Telephone WOrth 2-6180

HARRISON 12 WEST BROADWAY
 RADIO COMPANY NEW YORK Dept. C-12 N. Y.

The "2-Volt" Super DX-4

(Continued from page 471)

note that the capacity of the padding condensers increases as the frequency becomes higher; this arrangement gives much better "tracking" between the two tuned circuits than would be possible if only a single .001 mf. fixed condenser is used in series with the oscillator tuning capacity. As the padders are inside the coil forms, a correctly adjusted padding capacity is automatically placed in the circuit each time a different coil is plugged into the socket.

Coil Winding

The coils shown in the photograph are wound on standard 1½ inch, 4 and 5 prong, "plug-in" forms; the mixer coils being wound on the 4-prong forms and the oscillator coils on those of the 5-prong type. This distinction is made in order to prevent the mixer coils from being accidentally placed in the oscillator socket and vice versa. The 12-20 meter coils and those that cover the 19-40 meter range, are wound on the popular Hammarlund XP-53 low-loss "ribbed" forms; the others are of bakelite construction. Complete data for winding both the oscillator and the mixer coils for the entire 12-550 meter range will be found in the coil table at the end of this article.

In this receiver the 32 tube is used as a combined AVC tube and second detector. As shown in Fig. 1, an AVC potential is built up in the following manner: As the signal strength increases, more grid current flows through the grid circuit of the 32. The greater the grid current, the greater its D.C. component, and, as the resistor, R6, is actually a part of the 32 grid circuit when the AVC switch is thrown to the "on" position, the D.C. component of the voltage across it increases. The voltage drop thus obtained is applied to the control grids of the 1C6 and 34 tubes through the fixed resistors, R1 and R4. The chief disadvantage of an AVC system of this particular type, is due to the fact that it begins to operate as soon as a signal reaches the second detector and weak signals, therefore, do not receive the full amplification which the receiver is capable of supplying. However, this method is extremely simple and it is desirable for use with strong signals as it not only eliminates much of the fading and blasting but allows a considerable amount of amplification in the 32 second detector itself. In order that the very weak signals can be received and to allow the AVC action to be cut out when using a *beat-oscillator* for code work, the small D.P.D.T. switch at the left of the tuning dial is used to "short-circuit" the resistor, R6, and to place a negative six-volt bias on the 32 control grid when the toggle is thrown to the "off" position. No external bias is needed when the switch is in the AVC position, the negative bias necessary to produce rectification in the plate circuit being supplied by the signal itself.

Where Different Bands Come in on Dial

With the coils and the 150 mmf. (.00015 mf.) tuning condenser specified, the various *short-wave* bands should be received at approximately the following positions on the main tuning dial: With the 12-20 meter coils in the sockets, the 16 meter broadcast band appears at 60 and the 19 meter band is received at 93 to 95. Using the 19-40 meter coils, the 19 meter band is heard at 10 to 12, the 20 meter amateur band at 26 to 34, the 25 meter broadcast band at 40 and the 31 meter band at 73 to 75. With the 40-80 meter coils the 40 meter amateur band is tuned in at 25 to 35, the 49 meter band at 47 and the 80 meter amateur band at 95. The 80-200 meter range brings in the 80 meter amateur band at 20 to 40 and the 160 meter amateur band at 70 to 85. The remaining two sets of coils cover the standard 200-550 meter "broadcast" band.

It will be noticed that the most popular *short-wave* broadcast bands and the 20,

Please mention SHORT WAVE CRAFT when writing advertisers

RACO AC-4

A 4-TUBE A. C. 2 1/2 TO 555 METER COMMUNICATION RECEIVER
THE MOST REMARKABLE RADIO VALUE WE HAVE EVER OFFERED!

AND when we say communication receiver we mean it! The AC-4 is built to the highest amateur specifications for serious communication and long distance work. Isolantite insulated high frequency tuning condensers; continuous, all electrical, bandspread; etc. The 20 meter band, for instance, covers 100 degrees on the big 3 1/2" German silver bandspread dial with no hand capacity effect. Even if you already own a \$100 plus superhet, you will find when the auto ignition and other noises get you down you can still bring in those foreigners clearly on the AC-4.

No matter what band you are on you will have smooth bandspread tuning and perfect, stable regeneration control.*

This is also true of the ultra-high frequencies. You can use either plain or super-regeneration on 10 meters (for C.W. or phone) while on the 5 meter band it does a really swell job with low hiss level.

If you are a short-wave broadcast fan just notice the way the AC-4 opens up England, France and Germany, for instance, on the 25 meter band. There are a lot of superhets that can't equal that! And while you are making comparisons, tune in the same station (pick a weak one) on the 16, 19 or 25 meter bands with your superheterodyne and notice the difference in the noise level! That's a test which surprises a lot of people. If you already own an expensive short-wave receiver you still need the AC-4 as a reliable standby set. It will give you a standard of reception that will tell you when the big job is getting out of alignment; then, when it quits on you or the noise gets too heavy, just switch on the AC-4 and go on through.

*RACO receivers are noted for their perfect regeneration control. It is one of the secrets of their exceptional long distance foreign reception.

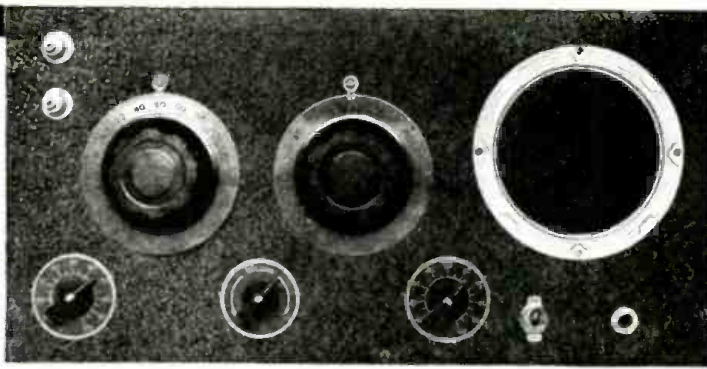

BUILT-IN A.C. POWER PACK

The AC-4 uses three of the new powerful Sylvania 6J5G tubes as detector and two stage audio and an 80 rectifier with built-in high voltage supply which is really quiet. Tunable hum is absolutely eliminated. Separate panel controls for antenna coupling, audio volume and regeneration. A standby switch is provided and also an earphone jack which cuts out the speaker.

NOTE

RACO does NOT use dressed-up junk parts in its receivers. All of our equipment is on display and demonstration at all times at our laboratory and you are cordially invited to inspect and operate it.

- RACO AC-1 Complete Kit of parts unwired, less only cabinet and tubes **\$10.75**
- Crystalline finished metal cabinet.....1.25
- Kit of four picked Sylvania tubes.....2.05
- Wiring and testing.....2.50
- SPECIAL PRICE ON COMPLETE RACO AC-4; wired, tested and ready to operate from any 110 volt A.C. line, with tubes and cabinet..... \$15.85**

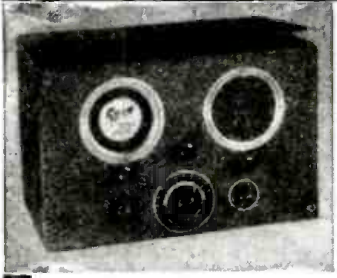

HAYNES R-S-R

5 TUBES
THE ORIGINAL
2 1/2 555-METER RECEIVER

Unquestionably the outstanding bandswitching, regenerative DX receiver. Hundreds of R-S-R owners, scattered over the whole world, are testifying to the splendid, consistent performance of this remarkable receiver.

Regeneration plus super-regeneration with exclusive double regenerative control.

The Most Copied Set But Still Unequaled

5 BAND selector switch covers from 555 down to 16 meters. No plug-in coils used over this entire range. High frequency range, on down to below 2 1/2 meters uses efficient, self-supporting interchangeable coils with special separate tuning condenser.

Complete R-S-R Receiver; ready to plug in to 110 volt line and operate; wired, tested, with 5 tubes speaker and cabinet..... **\$24.65**

Complete kit; unwired, including dynamic speaker, power supply and wired switch coil assembly (less only cabinet and tubes)..... **\$14.95**

R-S-R JR.

3-TUBE
Communication Receiver

2 1/2 to 555 METERS

A recent development of the famous HAYNES R-S-R at a remarkably low price for this class of receiver. A regenerative receiver with amazing selectivity.

continuous bandspread and perfect regeneration control over its entire tuning range. This is not the usual cheap toy set but one any amateur or short wave experimenter will be proud to own and demonstrate. Either super, or straight regeneration may be used on the high frequencies and, like the AC-1, this set is really good on the 5 and 10 meter bands. It is quiet, hum-free and has no hand capacity.

A.C. power pack is built-in with 80 rectifier. Uses new Sylvania 6J5G tubes as electron coupled detector and one stage audio. Front panel antenna coupling control, regeneration control and standby switch. Separate tank and bandspread condensers (latter is used alone on high frequencies).

A truly fine receiver, honestly built with good parts throughout, and capable of the very best DX work in spite of its surprisingly low price.

COMPLETE R-S-R JR. KIT; including all coils, drilled panel, chassis, power supply, etc.; less only tubes, cabinet and wiring..... \$7.60

Crystallized metal cabinet.....1.25
 Kit of three picked tubes.....1.25
 Assembled, Wired and Tested.....2.35

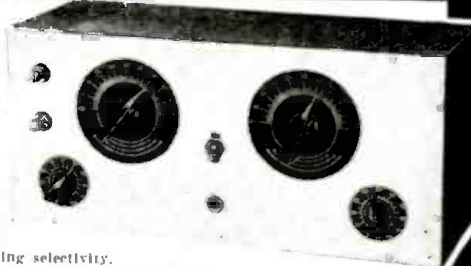

RADIO CONSTRUCTORS LABORATORIES

Dept. SW-12, 136 LIBERTY ST., NEW YORK, N. Y.



40 and 80 meter amateur bands are tuned in with the plates of the tuning condenser nearly all out. This gives a better L/C tuning ratio and, therefore, greater sensitivity. The 2 inch dial plate under the tuning knob is used for band-spreading purposes and makes the tuning on the crowded short-wave broadcast and amateur bands much easier. The arrangement shown, together with the 9:1 ratio tuning dial, spreads the 20 meter amateur band over nearly 95 degrees; the "spread" obtained on the 40 and 80 meter bands is more than 180 degrees.

Coil Table

Range in Meters	Turns Osc.	Turns Ticker Coil	Turns Mixer	Antenna Cell
17-20	3 1/2	7	4	3
19-40	6 1/2	4 1/2	7 1/2	3 1/2
40-80	15 1/2	8	20	13
80-160	42	15	52	32
160-270	94	20	126	31
270-600	120	25	160	31

Note: The short wave coils are wound with No. 22 D.C.C. wire, close wound; the 160 meter and broadcast band coils are wound with No. 30 D.C.C. wire, the latter being bank-wound every 15 turns. The padding condenser, CP2, inside each oscillator coil form has the following capacities: 12-20 meters, .006 mf.; 19-40 meters, .002 mf.; 40-80 meters, .001 mf.; 80-160 meters, .001 mf.; 160-270 and 270-600 meters, .0005 mf. All windings are baked to force out any residual moisture and then thoroughly impregnated with liquid Victron coil dope.

List of Parts for "DX-4"

- C1 2-gang tuning condenser, 140 or 150 mmf. (.00014 or .00015 mfd.).
- C2 Mica condenser, .00025 mf.
- C3 By-pass condenser, paper type, 1 mf., 300 volts.
- C4 Tubular condenser, paper type, .1 mf., 400 volts.
- C5-C6 Tubular condensers, paper type, 0.05 mf., 400 volts.
- C7 Tubular condenser, paper type, 0.2 mf., 400 volts.
- C8 Mica condenser, .00025 mf.
- C9 Tubular condenser, paper type, .1 mf., 400 volts.
- C-10 Mica condenser, .001 mf.
- C11-C12 Tubular paper condensers, .01 mf., 400 volts.
- C-13 By-pass condenser, paper type, 1 mf., 300 volts. (may be omitted).
- C14 Trimmer condenser, compression type, 35 mmf.
- CP1 Trimmer condenser, compression type, 35 mmf. (see coil table).
- CP2 Padding condenser, .006, .002, .001 and .0005 mf. (see coil table).
- R1 Carbon resistor, 10,000 ohms, 1/2 watt.
- R2 Filament rheostat, 15 ohms.
- R3 Wire-wound resistor, 100 ohms.
- R4 Carbon resistor, 10,000 ohms, 1/2 watt.
- R5 Carbon resistor, 50,000 ohms, 1 watt.
- R6 Carbon resistor, 500,000 ohms, 1/2 watt.
- R7 Potentiometer, wire-wound, 50,000 ohms.
- R8 Carbon resistor, 250,000 ohms, 1 watt.
- R9 Potentiometer, carbon-element type, 250,000 ohms.

- R10 Carbon resistor, 1 megohm, 1/2 watt.
- R11 Carbon resistor, 75,000 ohms, 1 watt.
- L1 Mixer coil (see coil table).
- L2 Oscillator coil (see coil table).
- L3-L4 Antenna and tickler coils (see coil table).
- I.F.T. Iron-core I.F. transformers, pre-tuned, 456 kc. (Two required).
- A.F.C. Audio-frequency choke, 800 henry or A.F. transformer with primary and secondary windings in series.
- R.F.C. R.F. choke, 10 mh., universal-wound type.
- SW1 Toggle switch, D.P.S.T. type ("off-on").
- SW2 Toggle switch, D.P.D.T. type (6 terminals).
- 1 7x9x2 inch electrical chassis.
- 1 7x10 inch electrical panel.
- 1 Airplane type dial.
- 1 6-prong isolantite socket (for 1C6 tube).
- 1 5-prong isolantite socket (for oscillator coil).
- 1 4-prong isolantite socket (for mixer coil).
- 2 4-prong bakelite sockets (for 34 and 32 tubes).
- 1 6-prong bakelite socket (for 19 tube).
- 1 ST-12 "jacket" shield for 1C6 tube.
- 2 ST-14 "jacket" shields for 32 and 34 tubes.
- 1 2 inch, 0-100 dial plate for "band-spread" (see text).
- 1 Set of knobs, binding posts, jacks, etc.

HAMMARLUND

- 6 5-prong coil forms (Hammarlund XP-53 recommended).
- 6 4-prong coil forms (Hammarlund XP-53 recommended).

RCA RADIOTRON

- 1 1C6 tube.
- 1 32 tube.
- 1 34 tube.
- 1 19 tube.

Please mention SHORT WAVE CRAFT when writing advertisers



NEW PEERLESS 20-DX CW and PHONE transmitter: Uses a 53 crystal oscillator and doubler and an 802 amplifier. Approximately 15 watts CW or 5 watts grid modulated phone. Self contained power supply. Built on a standard 10x17x3 chassis and is just the thing for an exciter unit. Completely wired and tested, ready to operate with coils for any two bands.

- Less tubes and crystal.....\$24.75
- Kit of tubes including 1-5Z3, 1-53 and 1-802..... 4.95
- Bliley type BC-3 40 or 80 meter crystals..... 3.95

PEERLESS Super-Sensitive SHORT WAVE CONVERTER

Makes a short wave superheterodyne of your present broadcast receiver. Operates with any type receiver. Self-contained power supply. Just plug in power cord and connect antenna and ground.

SPECIAL, complete ready to operate.....\$7.95

RED HOT SPECIALS

- Unmounted 160 or 80 meter crystals.....\$1.50
 - Bliley crystal holder..... 1.00
 - Featherweight earphones..... .89
 - Brush crystal earphones..... 5.30
 - New RCA Spiderweb ALL-Wave Antenna..... 5.37
 - Kit for 5 meters for above antenna..... .90
- TAYLOR, RCA, EIMAC, RAYTHEON TRANSMITTING TUBES IN STOCK!
Write for Characteristic catalogs FREE!

Latest communication type Amateur Receivers in stock. Write for trade-in allowance on your old receiver, and our time payment plan. Hallcrafters, Hammarlund, RCA, RME, National, etc.

CLOSEOUT! Peerless 3-tube Professional short wave receivers. Complete with 2 sets plug-in coils, 3 tubes and hum free power supply for.....only \$13.75

- 5" Magnetic Speaker.....\$1.09
- 6" Magnetic Speaker.....\$1.69
- 5" Dynamic Speaker..... 1.69
- 6" Dynamic Speaker..... 2.45

Cable Address "Uncledave"
Long Distance Phone 4-5746

Prices F.O.B. Albany Foreign Trade Solicited
Send for new Ham Catalogue—just out!

NBC's Chief Engineer Discusses Television and Short Waves

(Continued from page 465)

this system at one time seemed to hold considerable promise, owing to the apparent reduction in the natural (atmospheric) static problem in radio reception, he said that the other noises which are liable to be encountered, due to the reasons set forth above, counteracted the apparent good features; and that the best way to overcome static in radio reception was to use more power at the transmitter.

"Super-Power" Stations

Discussing "super-power" broadcast stations, this prompted the writer to ask Mr. Hanson what NBC was contemplating doing in the Eastern area, for example.

"At present," replied Mr. Hanson, "we have an application filed with the Federal Communications Commission to increase the power of WJZ to 500 kw. (500,000 watts, the same as WLW in Cincinnati). Also, the new vertical (non-fading) antenna system being installed for the WJZ transmitter, will most probably be put into operation this November."

Is NBC using the new system of grounding their vertical antennas at broadcast stations, with the radio frequency power fed to the grounded metal tower at a certain fractional wavelength above the base?

Mr. Hanson stated that this system was not being used at present in any of their stations, and that furthermore they had not experienced any serious trouble or interruption of transmission at their broadcast stations due to lightning discharges. As he explained it, a lightning arrestor gap and static leak is connected from the mast to the ground and this had been serving its purpose very well.

Mr. Hanson made the interesting comment at this point, that the General Electric Co., is interested in making a survey of the effects of lightning on antennas and the degree or strength of the discharge. In several NBC broadcast stations a lightning recorder is installed, which comprises a simple film placed between two small electrodes, in shunt to a section of the antenna. The strength of the discharge governs the degree or size of the graph recorded on the film, the exposure of the film being caused by the corona discharge occurring between the electrodes whenever the lightning discharge strikes the antenna system. This recorder is connected in parallel with the antenna and grounded.

"News" in Home by Ultra Short Waves

Do you think that ultra short waves may be used tomorrow to reproduce facsimile news bulletins and newspapers in our home, perhaps while we sleep?

Mr. Hanson, who keeps in touch with foreign developments both by his reading of technical papers and occasional visits to Europe, said that both the German and British radio interests had tried this with rather unsuccessful results. "However," he stated, "I believe that it is bound to come in some form eventually." In answer to a question by the writer, he stated further that he did not think that this news service would be picked up on the usual home radio receiver, but would be a special service to be used with a separate receiver for that purpose.

Do you think that telegrams tomorrow will be transmitted by the "facsimile" method on ultra or micro waves instead of by dots and dashes?

"This is already being done by RCA Communications on their micro-wave relay system operating between New York and Philadelphia (about 90 miles), and it would seem that tomorrow we will undoubtedly use an amplification of this system for the transmission of many forms of information. The telegrams are usually typewritten for transmission by "facsimile," as many of us are rapidly becoming very poor writers, but on occasion the signature or

POWERTONE 5-BAND 4-TUBE A.C. D.C. COMMUNICATIONS RECEIVER

- ★ Band Spread Tuning
- ★ 15-550 Meter Tuning Range
- ★ New Metal Tubes Used
- ★ Built-in Power Pack
- ★ 5 Band Wave Switch
- ★ A.C. D.C. Operation
- ★ Built-in Dynamic Speaker
- ★ Tone Control & Switch

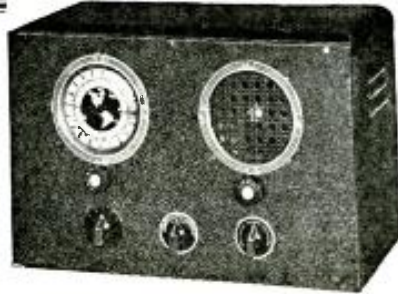

Some of the features found in this masterpiece of engineering are: Band Spread Tuning; Full Sized 4" airplane type dial. Adaptability to operate on either A.C. or D.C.; Elimination of plug-in coils by means of a Band wave switch; Built-in Dynamic Speaker; Use of the new Metal Tubes; and others too numerous to mention.

The circuit makes use of two of the new metal tubes. They are two 6K7's which are used to provide maximum selectivity and sensitivity. A 43 power pentode used to drive the dynamic speaker, and a 25Z5 tube used for rectification purposes.

Band Spread Tuning

Band Spread tuning of all signals is made possible by use of a large sized 4" airplane dial. The signal received is spread across the whole dial, thus aiding materially in tuning stations and provide better sensitivity.

- Complete kit of parts, including pictorial and schematic diagrams, unwired, less tubes and cabinet.....\$10.50
- net..... 2.50
- Wiring and Testing, extra..... 2.25
- 4 Matched Sylvania Tubes..... 2.25
- All Metal Crystal Cabinet..... 1.75



"Buddy-2" 2-Tube A.C. - D.C. Receiver.

Operates on either A.C. or D.C. Makes use of 1-6J7 metal tube and 1-12A7 as a combined rectifier and pentode output tube. Purchased with four plug-in coils which tune from 15 to 200 meters. Additional coils to extend the range down to 9 1/2 and up to 2000 meters are available.

- Complete kit of parts including pictorial and schematic wiring diagrams, unwired, less tubes, cabinet and additional coils.....\$4.50
- Wiring and testing, extra..... 1.25
- 2 Matched Sylvania tubes..... 1.50
- Crystallized metal cabinet..... .95
- 9 1/2-15, and 200 to 2000 meter coils..... 1.75

Powertone 5 Meter Portable 3-Tube Transceiver

It is a powerful low current consuming model featuring unity coupled circuit. Once you have established contact there is no trouble in maintaining contact when switching to sending and receiving positions. Makes use of 1-30 and type 19 tubes.



- Complete kit of parts including pictorial and wiring diagrams, unwired, less tubes, cabinet and microphone.....\$9.50
- Set of 3 matched Sylvania Tubes..... 1.48
- Portable All Metal Cabinet..... 1.93
- Wiring and Testing..... 2.50
- Matched Hand Microphone..... 1.75

TRY-MO RADIO CO., Inc. 85 Cortlandt St., N. Y. C.
POWERTONE ELEC. CO., Inc. 179 Greenwich St., N. Y. C.

Please mention SHORT WAVE CRAFT when writing advertisers

original written script may be transmitted by facsimile where legal and other matters are concerned."

Television

Television broadcasting—at once the most potent subject and the greatest hugaboo of the radio engineering or program director today, came up for discussion.

In answer to the writer's question as to how much of television broadcasting would be carried on from films or photoplays, and what part from "live" studio scenes and actors, Mr. Hanson was frank to say that he thought recent improvements seemed to indicate that the ratio of films versus "live" actors would run about fifty-fifty. Incidentally, Mr. Hanson mentioned that a concentric cable has been installed between Radio City and the Empire State Tower, a distance of about one-half mile, so that studio scenes might be transmitted when desired over this cable to the experimental ultra short wave transmitter on the 1,300-foot Empire State Bldg.

Do you think television programs may be distributed to various network television stations in the future by micro-waves, or is a concentric cable more feasible for the purpose?

"Distributing these programs by micro-waves with a suitable number of repeater stations, similar to the system used by RCA for transmitting facsimile images between New York and Philadelphia appears quite feasible," said Mr. Hanson.

Mr. Hanson seemed to feel that the micro-wave system would prove more economical than a concentric cable for network television. Suppose that such a concentric cable was installed between a number of the leading cities and the telephone company was able to transmit say 200 distinct telephone messages over this cable, by using a suitable number of differing frequency carriers. It will be seen that a considerable "cost item" would arise if, when the cable was to be leased for a television program, all of these phone messages had to be kept off the cable so as to provide its full frequency band width for a single television transmission. A frequency band of about two million cycles would be required for television. "In order to carry this television frequency," Mr. Hanson pointed out, "a greater number of repeater stations would have to be installed by the wire communication company operating the cable; about 100 per cent increase in the number of repeater stations required for carrying ordinary phone messages."

Short-Wave "News Pick-ups"

Which system is used the most today, "short-waves" or "direct-wire pickup" from such scenes as that occurring when the rescued passengers of the steamship, "Morro Castle" were brought ashore and recited some of their first-hand experiences over the broadcast networks?"

"The F.C.C. regulations govern that problem," said Mr. Hanson, "and it states that short waves for picking up such 'spot news' shall not be used." Obviously a mike in motion such as in a pack outfit or in an auto, ship or plane, must use short waves as the first link to an available wire line.

How does the quality or fidelity of American broadcasts compare with those heard in Europe? I ventured.

"I had a very good chance to make a comparison on a recent trip to Europe, and American listeners have nothing to fear in this direction; for one thing, the rules laid down by the F.C.C. require a very high standard of transmission quality. In one European country for example, I was shown amplifiers in the studio and other sections of the station, which had a remarkably high quality characteristic, but when I asked some questions concerning the harmonic content of the transmitter itself, the statement was made that this had not been checked up for several years. And so it goes—while certain parts of the radio apparatus may have been improved to a very high degree, the losses in other parts or sections negate the gains made."

★ IRON CORE I. F. TRANSFORMERS

★ PHONE JACKS ★ BEAT OSCILLATOR

★ A. V. C. ★ 5 TUBES ★ BAND CHANGE SWITCH

★ TUNES FROM 18 TO 555 METERS ON THREE BANDS

★ SINGLE DIAL CONTROL SWITCH

★ CUT-OFF SWITCH

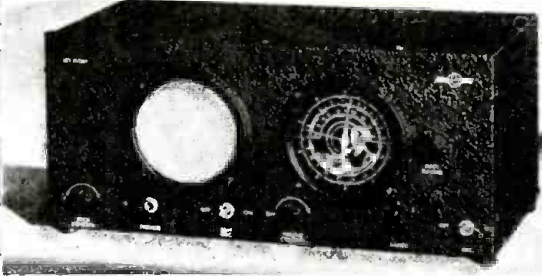

The SUPER SKY RIDER



The Leading American Communication Receiver. An Eleven Tube Superheterodyne tuning from 40 M. C. to 545 K. C. in 5 bands—Direct calibrated 338 dial—Improved 10 meter performance—Iron Core I. F. Transformers—14 Watts undistorted output.

★

The ULTRA SKY RIDER



Designed for better ultra high frequency operation. Tunes from 3.76 to 24 meters in 4 direct-calibrated bands. Equipped with built-in Noise Silencer, 16000 K.C. Iron Core I. F. Transformers, 10 All-metal tubes, electro-mechanical band spread.

★

The SKY RIDER COMMERCIAL



An eleven tube super especially fitted for commercial service. Tunes from 20 to 3000 meters. With the Ultra Sky Rider it provides complete coverage.

★

The SKY CHIEF



A new 7-tube Super with all the latest features—Tunes 17.3 M. C. to 540 K. C. in 3 bands. Variable Beat Oscillator, AVC, Iron Core I. F. Transformers, Built-in Speaker and Power Pack.

THE SKYBUDDY

a GENUINE hallicrafters
ENGINEERED
COMMUNICATION RECEIVER

for Only
\$29.50

Here's the latest HALLICRAFTERS Receiver—the "SKYBUDDY"—the five tube superheterodyne that has been acclaimed by experts and beginners alike. This genuine HALLICRAFTERS engineered junior model communication receiver has astonishing selectivity and sensitivity. It is a splendid receiver for the beginner, and at this sensationally low price is the greatest value ever offered in a short wave receiver.

IT FEATURES:

- Superheterodyne circuit
- Iron Core I. F. transformers
- Cut-off switch
- Megacycle and kilocycle calibrated dial
- Band-change switch
- "On-off" switch for beat oscillator
- Crackle finished metal cabinet
- Greater band spread—36 to 1
- Automatic Volume Control
- Five tubes functioning as 8
- Single dial tuning control
- Built-in power supply and loudspeaker
- Head-phone jack
- Provision for using double or straight aerial cabinet
- Tunes from 16.5 M.C. to 544 K.C. in three bands

These features make it suitable for either the licensed "Ham," Amateur or the Short Wave Listener. Expert short-wave operators are amazed at the performance of the "SKYBUDDY"—your one opportunity comes at this time to get a precision-built short-wave receiver at tremendous savings.

★
See it at your jobber, or write for complete detailed information today.

the hallicrafters inc.

2601 Indiana Avenue, Chicago, Ill.

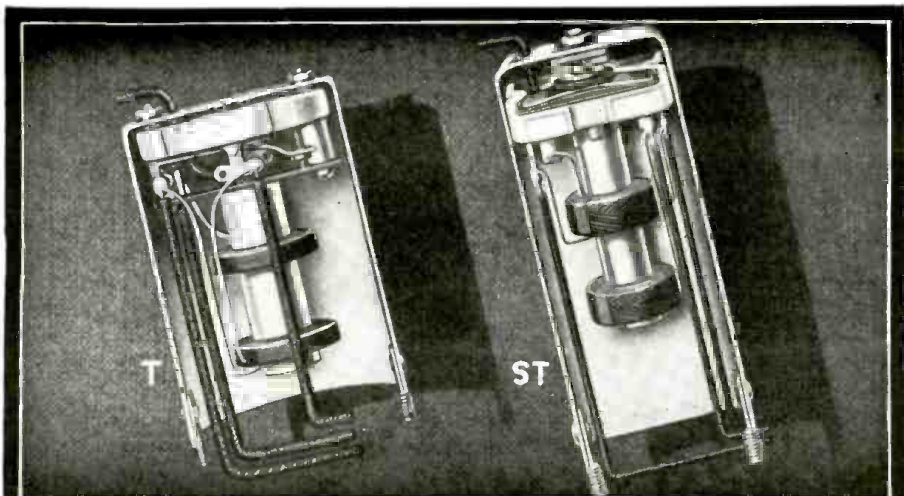

IDEAL I. F. TRANSFORMERS!

A group of I.F. replacement and experimental transformers by Hammarlund, for the critical engineer, research student, repairman and set-builder demanding superior results for better radio. Ten types in round can "T" model for 175 and 465 kc.

and square can "ST" model for 175, 262 and 465 kc. Tuned grid and tuned plate lattice wound coils, impregnated to prevent moisture effects. Here are truly quality transformers, and now available at the low price of \$1.45 each list!

Write Dept. SWC-12 today for "I.F." booklet!

THE HAMMARLUND MANUFACTURING COMPANY, INC.
424-438 WEST 33RD STREET, NEW YORK CITY

HAMMARLUND'S 25th YEAR

"Recorded" Programs not used by N.B.C.

What do you think of the "steel-tape" voice and music recorder or the Blattnerphone, used by the BBC in England, and a similar device used in Germany, for recording special programs where they are to be repeated several hours later for the distant listeners?

"In the first place," replied Mr. Hanson, "it is against the policy of NBC to repeat any canned program features which go out over their network. On my recent trip through Europe, I found that due to the high noise-level on the Blattnerphone, that both the English and the Germans are using more and more the American method of recording the program on cellulose coated disc (cellulose coating on an aluminum disc). And it might be interesting to note that all of the programs broadcast over the NBC network from New York City, are recorded on these records, not for re-broadcast, but simply for reference purposes in our files."

"The reason why the BBC, for example, find the recording of programs particularly useful," explained Mr. Hanson, "is because of the fact that they have to rebroadcast these programs in many cases on short waves over great distances, even half way around the world, to their various dominions. As will be seen, this involves considerable differences in time for as much as eight to twelve hours or more, and it would be inconvenient to call on the actors and singers to reappear in the studio at all hours of the night or early morning to repeat their performances."

Short Waves Kept "Lady Peace" in Touch With Land

(Continued from page 463)

accompany the "Lady Peace" out for approximately the first hundred miles of the flight, acting as a remote pick-up to broadcast via WOR and the Mutual Broadcasting System the timely details of the flight's start. Confirmations were subsequently received from 40 states!

New High-Freq. Cond.

(Continued from page 482)

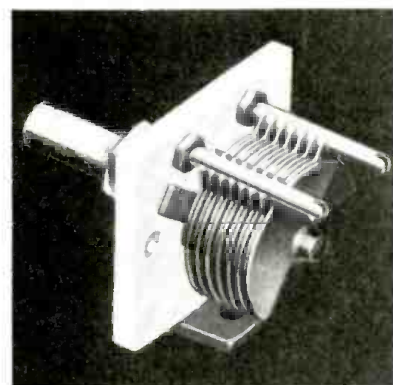

Low-loss midget condenser H-74

In the single unit any one of three different mounting methods may be used. One is a bracket or base mounting; another is a single hole panel mount; and the third is a panel mounting employing spacer bushings which permit complete insulation of both rotor and stator sections. Absolutely noiseless operation is another feature of these new condensers. Single models are available in sizes from 15 mmf. to 140 mmf. and a double spaced 30 mmf. model. These condensers are excellent for ultra high frequency work.

Girl Operators, Attention!

Listen "YL's" and "XYL's"! Why not send the Editor a good photo of your "Rig"—and don't forget yourself. A separate photo of yourself will do, with a "clear" photo of that station! \$5.00 for best "YL" photo.—Editor. See page 649 March issue for details.

PAR-METAL RACKS—PANELS—CABINETS

—a size and style for every requirement



PAR-METAL offers you a uniform line of standardized metal products that enables you to quickly build up a job that is professional both in construction and appearance.

THE RACKS, cabinets, panels, etc., are the result of many years' experience in making similar equipment for the sound industry. All of these products have been designed and made by a modern plant that has fabricated about everything from a small shield can to the metal work on a broadcast station.

All of the parts are available in various standard sizes—a complete line that will meet almost every requirement.

PAR-METAL PRODUCTS CORPN.
35-27 41st ST., LONG ISLAND CITY, N. Y.

★PEAK PRE SELECTOR PRE AMPLIFIER

HEAR STATIONS YOU NEVER HEARD BEFORE

The PEAK Regenerative High-gain Pre-selector tremendously increases the sensitivity and selectivity of any receiver. Greatly decreases noise to signal ratio. Rejects image.

- 9 to 200 meters
- Silver plated contact band change switch
- Self contained heater supply
- Automatic changeover switch
- Smooth control.

The P-11 is so easy to use; a moment and it is connected to any set. Every one is sold with an unqualified guarantee to markedly improve reception to markedly better than any similar unit sold!

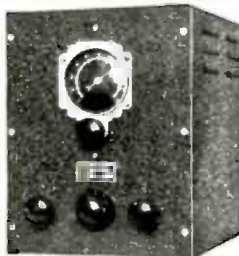

Improve reception with any receiver out of an old set! It will make a NEW receiver out of an old set!

HAMS! PEAK P-11 is highly recommended by Amateurs and Commercialists all over the world! Bring your weak, unreadable signals up to R-9! You can't work 'em if you don't hear 'em!

You just can't afford to be without the PEAK P-11! PEAK P-11, Complete, less two 5B tubes. List price \$33.00. Net price..... **\$19.80** At all leading Amateur Supply houses. Write for literature.

PEAK RADIO PRODUCTS
227 Greenwich St., C-12 New York City

ULTRA 5T ALL WAVE (1 1/2 to 600 METERS) 5-Tube A.C. & D.C. RECEIVER

- ★ New tubes 2-6K7, 1-6J5G, 1-25Z6, 1-25B6G
- ★ Electrical bandspread
- ★ Receives phone & C.W. signals
- ★ Built-in dynamic speaker
- ★ Built-in power supply
- ★ 9 bands
- ★ Dial illumination
- ★ Headphone jack

This new amateur communications receiver embodying a multitude of features including electrical bandspread, super regeneration from 1 1/2 to 15 meters, 2 watt power output made possible by the new super output tube 25B6G, and many others too numerous to mention, is now available for the use of the discriminating amateur. 1 1/2 to 600 meters linear in efficiency is accomplished by the use of super-regeneration up to 15 meters and straight regeneration with 5 band switching to 600 meters. The newest type tubes are used as follows: 6K7-RE stage, 6K7-regenerative detector, 6J5G ultra high frequency detector, 25B6G super power output stage, 25Z6G rectifier, Built-in dynamic speaker, Self contained A.C.-D.C. power supply, large illuminated airplane dial, automatic phone-jack.



Complete kit of parts less tubes and cabinet unwired.....	\$3.00	\$13.95
Wired and tested, extra.....	4.50	
Sylvania kit of 5 tubes.....	2.50	
Black wrinkle finished cabinet.....	23.10	

WRITE IN FOR FREE DESCRIPTIVE ULTRA HIGH FREQUENCY LITERATURE
ULTRA HIGH FREQUENCY PRODUCTS COMPANY
140 LIBERTY STREET
NEW YORK, N. Y.

A 1937 Desk Type Transmitter

(Continued from page 475)

piece of No. 12 wire connects each of these three heaters together. There are no twisted heater feed lines. All grid, plate and screen by-pass condensers are so placed that where the lead to be by-passed passes through the chassis, it immediately meets one terminal of the by-pass condenser which has already been soldered to the ground buswire. Probably the builder will follow some of his own ideas in constructing and laying out this transmitter, but we recommend very little deviation from the idea as presented.

We see in the photographs showing the top view that the oscillator grid coil is wound on a form. This is really essential for such a large coil wound with ordinary copper wire if frequency shift due to vibration is to be eliminated. The original MOPA using two 6L6's had a self-supporting coil. We recommend that a form be used in both transmitters as a precaution against undesirable frequency shift.

Types of Condensers Used

Referring to the diagram we find that in all circuits, other than the final amplifier plate circuit, we have used *midget* tuning condensers, 50 mmf. in the oscillator grid circuit and 15 mmf. in the oscillator and buffer plate circuits. The tuning condenser for the push-pull amplifier was made by remodeling a TMS-A, double spaced 50 mmf. condenser. The resulting condenser, as can be seen from the photograph, employs two rotors and two stators in each section. During the trials and tests through which this transmitter progressed, the following voltage and current values proved to be optimum: 250 volts applied to the plates of the oscillator and buffer stages and between 60 and 75 volts to the screen. The amplifier has 400 volts applied to the plates and under loaded conditions a grid current of between 8 and 10 ma. and a total screen current of about 20 ma. The no load amplifier plate current is 45 ma. and maximum of 150 ma. when loaded. The oscillator plate current will be found to be somewhere between 25 and 35 ma., and the same values will apply to the plate of the buffer stage.

Complete data regarding the construction of the coils, which, remember, match the condensers employed, may be found in the Coil Table. (See drawing of hook-up.)

Parts List for 5-Meter MOPA

NATIONAL CO.

- 2—15 mmf. STHS condensers.
- 1—50 mmf. STHS condenser.
- 1—TMS-A 50 mmf. condenser (remodeled).
- 4—Flexible couplings.
- 4—8-prong Isolantite sockets.
- 2—stand-off insulators.
- 1—30 mmf. padding condenser.
- 1—R-39 one-inch coil form, no prongs.
- 1—2.5 mh. R.F. choke.
- 3—large dials, type 0.
- 1—small dial and knob, type HRO.

CORNELL-DUBILIER

- 13—.001 mf. fixed condensers, mica, 1,000 volt.
- 1—.0002 mf. mica condenser, recv. type.

ELECTRAD

- 4—10,000 ohm, 35 watt wire-wound resistors.

PAR METAL

- 1—crackle finished 7x19x1/4 in. panel.
- 1—crackle finished 11x17x2 in. chassis with bottom plate.

RCA RADIOTRON

- 4—6L6 tubes.

MISCELLANEOUS

- 1—50,000 ohm 1 watt resistor.
- 5—single closed circuit jacks.
- 2—feet 1/4 in. shafting.

The New Doerle 6-Tube BANDSPREAD RECEIVER Marvelous Sensitivity and Selectivity Only Found in the Higher Priced Models

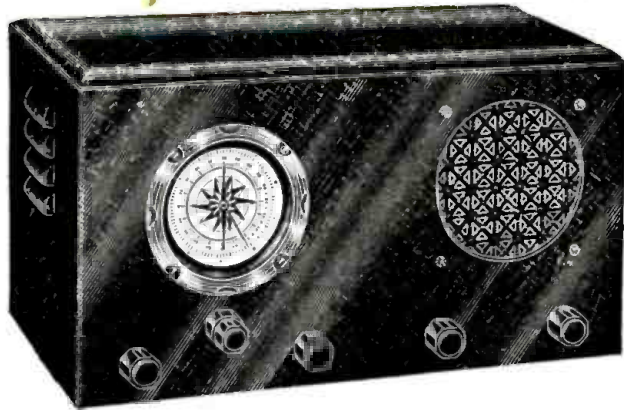

See editorial article on page 400, November SWC

- ★ Continuous bandspread tuning from 9 1/2 to 625 meters.
- ★ An ideal DX receiver for the long distance SW fan or communications receiver for the transmitting amateur.
- ★ Beautiful large, illuminated, dual pointer, multi-colored, airplane type dial of great beauty.
- ★ Operates from either single wire type aerial or noise-free doublet.
- ★ Volume control—stage aligning trimmer—and tone controls.
- ★ Unusually smooth acting regeneration control.
- ★ Headphone jack with plate voltage cut-off switch.
- ★ Highly efficient, low loss ribbed plug-in coils, are a large factor in the amazing sensitivity and selectivity of this receiver. Coils are of the large 3 winding variety and are color coded for easy identification.

The famous Doerle line of receivers are now equipped with the new *Oetal* sockets in which glass and metal tubes are interchangeable. For the first time this quality receiver is available in KIT form for the short wave experimenter who prefers to "build his own."

Uses 6 of the latest hi-gain tubes (6K7G, 6K7G, 6C5G, 6C5G, 6F6G and 5Y3) in a highly efficient and selective circuit, using *two tuned stages*—electron coupled regenerative detector—POWERFUL 3 stage resistance capacity coupled audio frequency amplifier with power pentode output stage—full wave high voltage rectifier and self contained hum-free power supply. Built-in High Fidelity dynamic speaker capable of handling the entire 3 watts of audio frequency power output of the receiver.

Continuous bandspread over the entire range of 9 1/2 to 625 meters is obtainable due to the use of a special type, multi-colored, airplane dial having 125 to 1 ratio and *two pointers*. Two knobs are provided and make possible either fast or slow motion tuning. ALL of the AMATEUR and FOREIGN SW BANDS are spread over a generous portion of the tuning dial, thereby simplifying tuning so that even a beginner can operate it to the utmost satisfaction. Entirely free from all traces of backlash.

The entire unit is contained in a large, black crackle finished metal chassis and cabinet of extreme beauty. All controls are mounted on the front panel and all parts are readily accessible. No adjustments whatever are necessary. Nothing to get out of order. Simply plug into your electric light socket and enjoy an evening of short wave thrills and entertainment such as you have never before experienced.

Mechanical specifications: Dimensions are 17 1/2"x8"x8 3/4". Net weight 23 lbs. Shipping weight 33 lbs. Designed to operate entirely from 100-130 volts, 50 to 60 cycles AC house current. Shipment made same day as order is received. Complete satisfaction guaranteed.

DOERLE 6-tube AC BANDSPREAD RECEIVER, completely wired and tested, with set of 6 matched Arcturus tubes, 8 coils for 9 1/2 to 200 meters, cabinet, instructions, and READY TO OPERATE.....
 (Specify whether metal or glass tubes desired.)

DOERLE 6-tube AC SW KIT, containing all necessary parts, including 8 low loss ribbed coils for 9 1/2 to 200 meters, full size hi-fidelity dynamic speaker, beautiful cabinet, and 4 page instruction booklet (less tubes, Broadcast coils, and unwired).....

6 Arcturus matched tubes.....\$3.12
 Broadcast band coils (2).....1.45

INVEST in a GENUINE DOERLE 2-TUBE BATTERY RECEIVER

15 to 200 Meters

One of the most popular members of the Doerle Set family. Employs but two tubes, yet gives the performance of a set having three tubes. Uses a type 30 as regenerative detector and a type 19 twin triode (actually 2 tubes in one) as two stages of resistance-coupled audio. The world-famous reputation of the entire Doerle line, is behind this remarkable set. Requires two No. 6 dry cells and two 45 cell "B" batteries for operation. All parts and workmanship fully guaranteed. Employs a set of four 5-prong ribbed plug-in coils. These coils are interchangeable with the new 5-prong bandspread coils. Ship. wt., 10 lbs. List Price \$15.75.
 Doerle 2-tube Battery Receiver Kit, not wired, but including Coils, less Tubes, Batteries and cabinet. YOUR PRICE.....
 Set of 2 Matched Tubes.....\$0.98
 Metal Cabinet for above.....1.25
 Set of 4 Bandspread Coils.....2.95



\$7.25
 KIT
 Less Tubes, Cabinet, and Batteries

\$7.25

We will wire and test any of these kits at an additional charge of \$1.50

FREE CATALOG OF DOERLE RECEIVERS. Send stamp to cover mailing costs.

GUY STOKELY RADIO CORPORATION, 126 Liberty St., Dept. S-12, New York City
 SOLE MANUFACTURERS AND DISTRIBUTORS OF DOERLE SETS

Don't miss the big January HAM number!

Please mention SHORT WAVE CRAFT when writing advertisers

A "Real" 5-Meter Super-Het

(Continued from page 469)

this lug, while those under the chassis connect to the other lug under the same screw. The same system is followed in the detector and I.F. circuit. In the diagram we have illustrated how this is done.

Receiver Can Tune in Television Signals

Midget 15 mmf. tuning condensers are used so that a fairly wide coverage could be obtained. This enables the receiver to tune up to the television stations and also well below the 5-meter band. In order to make tuning comfortable the National PW-O dial was employed. This is another very important part in the operation of the receiver inasmuch as although large tuning condensers are used, tracking has been made so easy that it *out-shines* any band-spread method that might be employed. The ease in tuning, of course, is due solely to the dial which is a beautiful piece of mechanical engineering.

How "Trimming" Is Done

No special tracking arrangements are shown in the circuit of the oscillator and detector other than a small *trimming condenser*, which is used solely for bringing the stages into resonance. Tracking was accomplished by altering the spacing in the condensers. They can be made to track perfectly if the oscillator tuning condenser rotor plates are spread in a tapered fashion at the maximum capacity position. In other words, turn the condenser in all the way to maximum capacity and spread the outer edges as shown in the drawing. The spreading, of course, is done on the *long* side of the shaft. It requires only about five minutes to do this job and from then on the tracking problem is eliminated. The inclusion of padding and tracking condensers in the oscillator circuit would be most undesirable and quite ineffective.

In lining up the I.F. stages, the best procedure is to set the tuning condensers in each transformer at one-half capacity, then with some sort of short-wave oscillator, such as the detector of a regenerative receiver with regeneration control turned on far enough to make the detector oscillate, tune the oscillator from 5,000 to 3,000 kc. Somewhere in this region, probably at about 4,500 kc., you will hear the swishing sound of the oscillator. The frequency can then be checked with a frequency meter, if you wish it to be set on some exact frequency, or it can be left "as is" and the I.F. transformers adjusted for maximum output, keeping the *gain control* of the amplifier as low as possible.

If, for instance, one of the condensers in the I.F. transformers cannot be tuned to a peak, because of the fact that its capacity is at maximum or the minimum, then an adjustment of the other trimming condenser in the same transformer will correct the condition. Some juggling of the two condensers is necessary in order to get perfect alignment. This is due to the effect each circuit has upon the other, due to close coupling between the coils.

Parts List for the Superhet

- 3—FXT tuning assemblies.
- 3—15 mmf. STHS tuning condensers.
- 1—30 mmf. padding condenser, M-30.

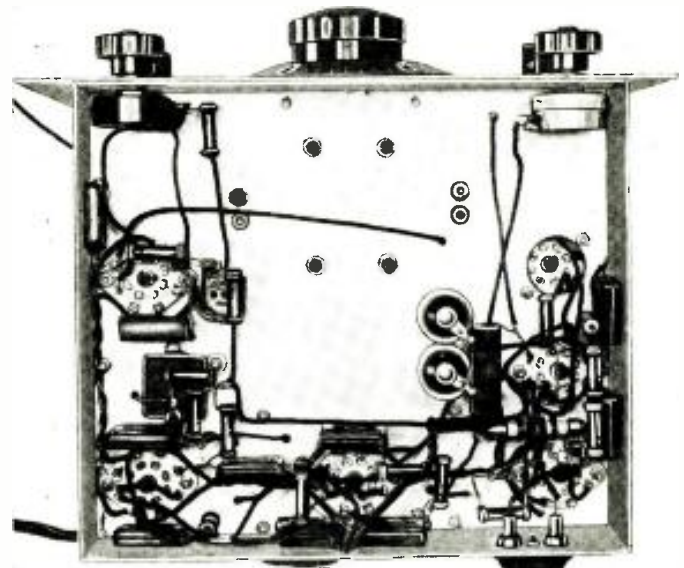

Bottom View of Set.

- 6—XC8 Isolantite sockets, 8 prong.
- 1—R.F. choke, 2.5 mh., R-100.
- 1—PW-O, dial assembly.
- 2—shaft couplings, TX-9.
- 2—small dials, type HRO.
- 2—knobs.
- 4—grid clips, type 8.

AEROVOX

- 12—.01 mf. mica condensers.
- 1—.001 mf. mica condenser.
- 1—.00025 mf. mica condenser.
- 1—.0001 mf. mica condenser.
- 1—.006 mf. mica condenser.
- 1—.01 mf. mica condenser.
- 2—5 mf., 25-volt electrolytic condensers.
- 1/2 watt resistors.
- 1—200 ohms.
- 2—300 ohm.
- 2—50,000 ohm.
- 4—10,000 ohm.
- 3—100,000 ohm.
- 1—250,000 ohm.
- 1—500 ohm, 1 watt.

TUBES

- 1—6AK Tube.
 - 1—6C5 Tube.
 - 2—6K7 Tubes.
 - 1—6J7 Tube.
 - 1—6F6 Tube.
- Tubes with Isolantite insulation preferable.

ELECTRAD

- 1—50,000 ohm potentiometer.
- 1—2,000 ohm potentiometer.
- 1—.5 meg. potentiometer.

MISCELLANEOUS

- 1—heavy aluminum chassis, 9x10x2 inches.
- 1—heavy aluminum panel, 7x12 inches.

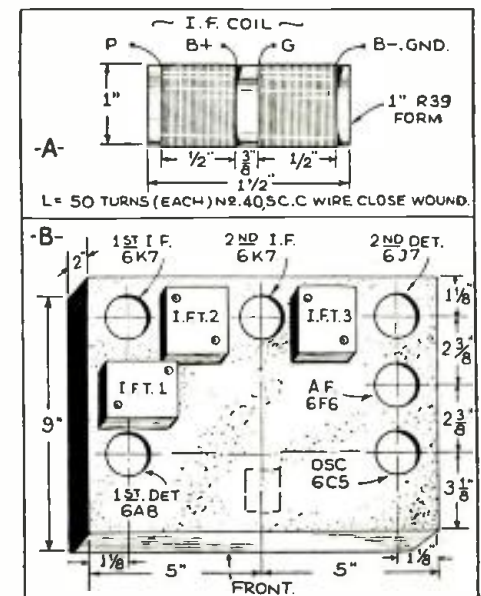

Detail of Chassis.

CROSLEY SUPER SENSITIVE RADIOS

THE WORLD IS YOURS WITH THE NEW 1937 CROSLEY RADIOS

The 1937 Crosley Radios reach out to bring you the world's finest programs—in short wave or regular broadcast. A twist of the dial takes you across continents, seas, hemispheres . . . to bring the world into your home. And you'll like these new Crosley models for other reasons, too . . . for their marvelous tone . . . their amazing performance . . . their graceful designs . . . their moderate cost.

A COMPLETE LINE OF NEW MODELS

Distinctive modern cabinets . . . 5 to 15 tubes . . . two and three wave bands, embracing a range from 16 to 555 meters . . . and featuring the exclusive Crosley Auto-Expressionator, the Mystic Hand, Cardiamatic Unit, and 10 other advanced Crosley features. See and hear these 1937 Crosley Radios at your Crosley dealer's now.



CROSLEY MODEL 1516 CONSOLE

Fifteen Tubes . . . Three Bands . . . 16 to 50 meters, 50 to 160 meters, 160 to 555 meters . . . Octal-Base, Metal Tubes . . . Auto-Expressionator . . . Cardiamatic Unit . . . Mystic Hand . . . High Fidelity . . . Triple-Twin, Push-Pull Output . . . Illuminated, Full Vision, Magna-Ceramic Dial . . . Band Indicator on Dial . . . Vernimatic Dial Drive . . . Time Log Tuning . . . Automatic Volume Control . . . Six-Step Fidelity Control . . . Vibraoustic Sounding Board . . . 15" Curvilinear Speaker. Dimensions: 14 1/4" high, 23" wide, 13 3/4" deep . . . **\$174.50**

POPULAR SHORT WAVE CROSLEY MODELS

Table Model	744—(16 to 555 m.)	7 tubes	\$ 49.95
"	745—(16 to 555 m.)	7 tubes	49.95
Console	750—(16 to 555 m.)	7 tubes	67.50
"	760—(16 to 555 m.)	7 tubes	79.95
"	589—(16 to 555 m.)	9 tubes	99.50
"	1199—(16 to 555 m.)	11 tubes	109.50
"	1211—(16 to 555 m.)	12 tubes	129.50
"	1313—(16 to 555 m.)	13 tubes	149.50

Prices slightly higher in Florida, Rocky Mountain States and west.

The CROSLEY RADIO CORPORATION CINCINNATI, O.

POWEL CROSLEY, Jr., President
Home of "the Nation's Station"—WLW—70 on your dial—and Short Wave Station W8XAL—49.5 meters.

YOU'RE THERE WITH A CROSLEY

Please mention SHORT WAVE CRAFT when writing advertisers

Even The Tugboats Go Short-Wave!

(Continued from page 462)

the authority of the Federal Radio Commission, the New York Telephone Company completed the transmitting station. Development and improvements in the equipment, however, continued. Special effort was made to produce *ship equipment* which could be operated effectively and more economically than was possible with existing sets. The result was a low-powered five-watt set which has been installed on the seven boats.

Boats Called by Selective Signaling

An improved method of calling the boats by means of *selective signaling* apparatus also is being utilized. Under the old system of loadspeaker monitoring, the ship crew had to listen constantly for the ship's particular call. But with selective signaling, a *regular telephone bell* rings on the ship being called, obviating any confusion. The manipulation of the ship telephone is nearly the same as that of the ordinary telephone, thereby making skilled operators unnecessary on the boats.

The trial which has been carried on over a period of about two months has resulted in changes and adjustments which have developed a smooth working and speedy system of communication. Further tests are in progress in connection with the handling of large numbers of messages which might arise in the future under emergent conditions, such as in "foggy" weather.

Engineering Data Free

- SOME very valuable engineering data, useful to every short wave student and "Ham," including articles explaining how to Improve Modulation in Transmitters, Graphic Charts for the direct conversion, without computation of Watts to Decibels, Converting Loss or Gain into Decibels, and a chart showing graphically the relation between Ohms, Current and Decibels, as well as Ohms, Voltage and Decibels are presented in the new "Kenyon Engineering News."

If you would like a free copy of this very important compilation of engineering data, ask for No. 516 and address your request to
Service Department, Short Wave Craft, 99 Hudson St., New York City.

The sequence of operations when some one in the tugboat owner's office calls a tug is interesting, and the accompanying schematic diagram shows what happens. If a call is made from a subscriber's regular phone, then the call would pass through the nearest telephone exchange and it would then proceed through the marine operator's switchboard in the "long distance lines" at 32 Sixth Ave., New York City. Here a girl operator (known as the "marine operator") would route the call to the tug through a short-wave transmitter located on Staten Island. She would then proceed to call the desired tug by means of a dial, the same as used on the ordinary telephone.

If the tug was No. 7, for instance, then a prearranged sequence of signals would be flashed from the S-W transmitter, and when this particular sequence of signals was picked up on the 2590 kc. frequency channel over tug No. 7's antenna, its receiving set, which is always switched on, would cause the bell on the instrument in the captain's cabin to ring. The captain, or other officer, would then lift the receiver from the hook, having first flipped a switch.

The path of the short-wave voice from the tug, transmitted on 2198 kc., would be to the radio receiving station located on Staten Island, and from here back over the submarine cable to the *marine operator's* position at 32 Sixth Ave., New York City. From the switchboard at this position, the incoming voice from the tug would proceed over a regular telephone exchange to whatever subscriber's phone the person originating the call might be talking from.

Big Values in New Amateur Equipment in your ALLIED CATALOG

"What's New in Amateur Gear?"

You'll find the answer in your new 1937 ALLIED Catalog. This great 152 page book includes a complete Amateur Section packed with a tremendous assortment of transmitters, receivers, transceivers in factory-built and kit form—at the lowest prices. See the latest in Amateur transmitting and receiving gear, the new All-Star X'mitter, Knight Metal Tube Super-Gainer, 5 Meter Transceiver, Metal Tube DX'er and dozens of other Build-Your-Own kits; read all about the new National "One-Ten" and NC-100 receivers; Hallicrafters Sky-Buddy, Sky-Chief, and Ultra Sky Rider; Sargent Models 10AA, 11AA, and 11UA; RCA ACR-136, and many others. You'll find all your radio requirements answered in the new 1937 ALLIED Radio Catalog—if you haven't your copy send for it today!



Fastest Service—Lowest Prices Highest Quality

Our tremendous stocks are the most complete in Radio. No delays—you get what you want—when you want it. We buy in vast quantities, get lower prices and pass the resulting savings on to you. Our centralized, single location means faster service for you; our own "Ham" staff is ready to help you to select the equipment you need at the prices you want to pay. Keep in step with the newest developments in Amateur Radio—save time, trouble and money—read your ALLIED Catalog for RADIO'S GREATEST VALUES!

ALL STANDARD LINES

Your ALLIED catalog is crammed with complete lines of the latest products of Sargent, Hammarlund, RCA, Hallicrafters, National, Peck, Thordarson, and other leading manufacturers. When you order from ALLIED you know that you are getting only the finest of standard high-grade lines—tested and approved by ALLIED expert engineers.

EVERYTHING IN RADIO AT LOWEST PRICES!



Besides the latest in Amateur Gear ALLIED'S new 152 page Catalog shows more than 10,000 exact duplicate and replacement parts; dozens of Set-Builders' Kits; 38 new sensational Knight Radios—from 5 to 19 Tubes; newest Public Address Equipment—8-60 Watts—permanent, portable and mobile, for every sound need; complete lines of Test Instruments—oscillographs, analyzers, set-testers, tube checkers, meters, etc.; Rurl-power units and Windchargers; tools; books, etc.—Radio's Most Complete Supply Guide!

Allied Radio Corp., 833 W. Jackson Blvd., Chicago, Ill., Dept. 3-M

Rush me a Free Copy of your 152 page 1937 Catalog showing the latest Amateur Equipment and complete Radio Supplies.

Name _____
Address _____
City _____ State _____

ALLIED RADIO

833 W. JACKSON BLVD. CHICAGO.

Have you a Binder in which to keep your copies of SHORT WAVE CRAFT? Order one today—\$1.25. Holds 12 copies. Short Wave Craft, 99 Hudson St., N.Y.C.

RADIOS

ALL NEW 1937 MODELS

SAVE UP TO 50%

DEAL DIRECT—FACTORY PRICES! Iron-Clad Guarantee Written

A penny post card brings you our new, full color 16-page BARGAIN CATALOG free. Many models to choose from—4 to 19 tubes. AC/DC, All-Wave and new Farm sets that operate like city radios! Send post card or coupon below for full details of 30-day no-risk trial and Agent-User proposition. Write now!

30-DAY NO-RISK TRIAL! \$6.98

MAIL COUPON

Free Catalog

GOLDENTONE RADIO CO. DEPT. C, DEARBORN, MICH. Without obligation, send me new 1937 catalog and 30-day trial plan.

Name _____ Address _____

UNIVERSAL VELOCITY AND CARBON MICROPHONES

Universal's latest achievement—ideal for stage use—Not affected by temperature or humidity—Flat frequency response curve from 40 to 10,000 c.p.s.; Output 63 db. Low impedance or direct to grid types. Compact 2 1/4 x 4 3/8 in. by 1 1/2 in. thick—Weight, less than 18 oz.—Head swings to any desired angle—Beautifully finished in black enamel and artistic chrome plate—ask for new catalog sheet describing models RL, RP, RH and CB—List \$22.50—Latest model music type sectional stand for above microphones—List \$10.00.

UNIVERSAL MICROPHONE CO., Ltd. 424 Warren Lane Inglewood, Calif., U.S.A.

Please mention SHORT WAVE CRAFT when writing advertisers

Actual Modulation Percentage Shown on Direct Reading

Scale TRIPLETT MODULATION MONITOR



MODEL 1295

Dealer Price

\$24.83

for All Voice Transmitting Stations

Eliminates the uncertainty of depending on the ear, variation of antenna ammeter or the loop and light in determining carrier shift and percentage of modulation. Actual modulation percentage is shown on direct reading Triplet twin precision instrument. All readings in peaks. Scale indicates modulation from 40 to 120 per cent. Visual information on second dial provided for carrier reference level for the modulation test and also to check carrier shift during modulation. All uncertainties regarding final adjustments on the transmitter eliminated with the use of Triplet's Modulation Monitor. Prevents monkey chatter, cross talk and B.C.L. interference. Factory calibrated and no further calibration needed.

Model 1295 MODULATION MONITOR Complete with necessary accessories Dealer price..... **\$24.83**

This is a Triplet Master Unit

See the Modulation Monitor at your jobbers. Triplet manufactures a complete line of precision Radio Testing Equipment and precision Electrical Measuring Instruments for the amateur and experimenter. Complete information available on request. See your jobber—write for catalog



The Triplet Electrical Instrument Co. 2812 Harmon Drive, Bluffton, Ohio.

Without obligation please send me more information onModel 1295 Modulation Monitor.

I am also interested in.....

Name

Address

City State.....
8-29-36

One Tug Can Talk to Another

If it is desired to speak from one tug to another, the procedure in calling is just the same as in placing a call from tug to shore. The marine operator at 32 Sixth Ave., New York, would direct the technical operator at the radio receiving station on Staten Island to throw a "bypass" switch, which would permit the direct linking of the radio receiving station to the radio transmitting station. However, the marine operator at Sixth Avenue would still be able to monitor the conversation over her wire connection.

No operator is stationed at the transmitter, located about two miles from the receiving station, the transmitter being remotely controlled from the receiving station position. A flat switch member is fitted in the hand-set which is used by the tugboat captain. When he wishes to talk to shore or another boat, he presses this lever and when he wishes to hear he releases it. The captain has a volume control knob and also a master control knob on the panel alongside him.

If two tugboats should try to call up at the same time, in view of the fact that at present all of the boats are using the same frequency for transmitting and receiving, one would have to wait until the other finished. As all receivers are tuned to the same frequency channel, the captain of the second tug would hear tug number one talking and would know that he would have to wait.

Mr. H. Gernsback, the editor, made an interesting suggestion which may prove very useful in the near future—Why not expand the use of this "harbor service" short-wave phone, so that one of our great leviathans of the deep, such as the "Queen Mary," could talk to the tugs directly, when docking, instead of having to use whistle signals or yell through a megaphone from the bridge?

In answer to a query as to whether ferry-boats might be fitted with this short-wave phone, it was said that they could have this equipment if desired, but there is no apparent need for its adoption just now.

25 Watt Junior Transmitter

(Continued from page 481)

gives an indication of relative efficiency, when used with the same antenna but with different plate inputs to the final amplifier.

Parts list for Trutest 25 Watt Jr. Transmitter Kit

- 1—56 Socket; 1—53 Socket; 2—46 Sockets; 4—5 Prong Pl. Sockets.
- 1—1000 ohms 10 watt resistor.
- 1—1500 ohms 10 watt resistor.
- 1—100,000 ohms ½ watt resistor.
- 1—0.50 milliammeter.
- 1—0.150 milliammeter.
- 2 Feet rubber-covered wire for meters.
- 20 Bakelite extruded washers.
- 24 No. 4 P. K. Screws.
- 10 No. 8 P. K. Screws.
- 14 6/32 Machine Screws.
- 10 Grommets
- 2 Feed thru insulators.
- 4 Meter Lugs.
- Meter Hardware.
- 15 Ft. hook-up wire.
- 5 Lengths spaghetti.
- 6 Solder lugs.
- 2 Lug strips.
- 2 Wing nuts.
- 7 Rings for sockets.
- 2 Phone plugs.
- 4 Jacks.
- 6 Knobs.
- 2 Dials.
- 2 R.F. Chokes.
- 3 Variable condensers 100 MMF.
- 1 Variable condenser 30 MMF.
- 1 Variable condenser 40 MMF.
- 1 Variable condenser 250 MMF.
- 1 Steel Cabinet & Panel.
- 6 Mica condensers .003 mf.
- 1 Mica condenser .0001 mf.
- 5 Terminal strips.
- 8 Name plates.

This article has been prepared from data supplied by courtesy of Wholesale Radio Service Co.

ARCTIC EXPEDITION PRAISES DEPENDABILITY OF ASTATIC D-104 "Speech Range" CRYSTAL MICROPHONE



Actual photo of D-104 in use at Arctic short-wave base in Bay of Fundy.

Bowdoin Ornithological Expedition again chose Astatic Model D-104 for second year in Arctic because of its absolute dependability in transmitting clear messages back to civilization.

KNOWN ALL OVER THE WORLD FOR VOICE TRANSMISSION SUPERIORITY

Especially designed for strong, clear signals in the "speech range," Model D-104 has a frequency response especially appropriate for amateur work under every sending condition.

Noted for its rugged construction, freedom from microphonics and resistance to effects of atmospheric conditions. List Price \$22.50.

Ask your jobber for further information and write for Bulletin 58.

Licensed under Brush Development Company Patents. ASTATIC MICROPHONE LABORATORY, INC. Dept. S-WC, Youngstown, Ohio, U.S.A.



1-Tube Air Scout Jr. \$1 Radio

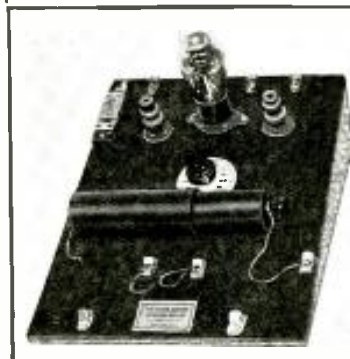

\$1 WITH TUBE

less batteries, phone, unsired

A Real Radio—Keen Reception. Kit includes every part needed, including tube. These mount on 8 1/2" x 11" wood panel not in kit but easily made. Full-size picture layout. Detailed instructions. Fun to build. Educational. Entertaining. Not a toy. Uses cheap batteries. FREE: Genuine Find-All Coil used in Air Scout Jr. sent postpaid on receipt 10c for handling costs. Extra 10c brings picture diagram with values of all parts.

H. G. Cisin, Chief Engineer ALLIED ENG. INSTITUTE Dept. S-31 98 Park Place New York, N.Y.

23 LANGUAGES

SPEAK ANY MODERN LANGUAGE IN 3 MONTHS BY LINGUAPHONE UNIQUE METHOD BRINGS VOICES OF NATIVE MASTERS INTO YOUR OWN HOME.. SEND FOR FREE BOOK

LINGUAPHONE INSTITUTE 73 Rockefeller Center · New York

Please mention SHORT WAVE CRAFT when writing advertisers

Hoover "Tinymite"

(Continued from page 466)

At Macon, Georgia, on a 7 foot aerial, W8XK, Pittsburgh, Pa., came in, giving instructions to those hauling drinking water during the drinking water shortage in the winter flood. The volume was good. Amateur and airplane stations in Florida were also received.

At Chicago, Ill., in May, 1936, on a seven-foot aerial, the Oakland, Calif., airplane ground station was heard reporting the arrival of a plane. Pilots were heard 9,000 feet up, talking to ground stations, with good volume. These pilots were within 200 miles of Chicago; one being heard as far as Memphis, Tenn., at 3,000 feet altitude.

Amateurs in the 9th district were heard and W8JOP, at Toledo, came in with a wallop. Memphis, Indianapolis, Omaha, Salt Lake City, Cleveland, Toledo, Buffalo, and Albany ground stations were heard talking to one another and to pilots. The set worked best on planes from 4 to 7 p.m. They change frequencies at night.

At Rochester, N.Y., an amateur in Terre Haute, Ind., came in good, as well as numerous amateurs in the 8th district, further reports Mr. Hoover.

This set is a "humdinger" to experiment with for DX reception—however, the aerial condenser must be accurately adjusted. On planes it worked well when screwed way out; on amateurs it was screwed down tight.

This circuit is not new; it is practically the same as that for the pocket set described by Mr. Stuart in *Short Wave Craft* some time ago.*

The parts are a little difficult to get but can be had from manufacturers. Fixed condensers from Aerovox; resistors from I.R.C.; 50 mmf. variable APC condenser from Hammarlund or any radio supply house; tubes from any supply house or radio store.

A cap from a 10c cigarette lighter fits over the top of the tube for a shield and is grounded to the shield on set when receiving.

A small screw must be soldered to the Hammarlund APC condenser before it is mounted on the panel, so that the knob which turns it around can be mounted on the condenser screw.

SOME OF THE STATIONS HEARD ON THE "TINYMITE"

At	Pilots	75 and 80-meter phone
Rochester, N.Y.		
Airplane Stations at:	one 6,000 feet up near	W9KFE, Richmond, Ind.
Chicago	Newark, N.J.	W8BZZ, Zanesville, Ohio
Cleveland	Code	W9KGI, Chicago, Ill.
Omaha	EAR } Spain	W8TPB, Evanston, Ill.
Salt Lake City, Utah	NDO	W9MBC, Terre Haute, Ind.
Newark, N.J.	KNA	W3CC, location unknown
Tylertown	ZHP	W8CF, location unknown
Allentown		W8RC, location unknown
Pittsburgh	1 CQ from Europe.	

* See Dec., 1934 issue of *Short Wave Craft*.

What I Saw at the New York Radio Show

(Continued from page 464)

were on exhibition—of suitable sizes to match most any pocket-book. All-wave receivers of various sizes are fitted into very elaborate cabinets, the top part of which opens up so as to form a dandy home bar. They are fitted with chromium-plated metal linings in the "bar" compartment and have a full set of glasses, bottles, etc.

Then there was a remote-control-unit, which enables you to sit in your favorite easy chair and tune in any desired station, even though the set is on the opposite side of a large room. One set had an "economy" switch on it, so that while listening to "locals," less current (watts in fact) is consumed.

CASH IN ON THE MOST SENSATIONAL TRAINING PLAN IN RADIO'S HISTORY



I Will Prove That I7c a Day

(Just About the Cost of a Pack of Cigarettes)

ACTUALLY SETS YOU UP FOR BUSINESS

RIGHT!...Is the Time to Get Started in an Industry that NOW!...is Making Fortunes for Live, Wide Awake Men.

THIS new and different kind of Training does more than teach you about all branches of Radio. It teaches you Radio-business methods—it sets you up ready for an actual start in business—and it backs every step of your training with REAL PROFESSIONAL RADIO EQUIPMENT!

No matter what kind of Radio Training you take, it is absolutely necessary that you have equipment of this kind BEFORE you are ready to start making real money.

Sprayberry Training brings it to you almost at the start—teaches you just how to use it under actual working conditions. Upon completion you have COMPLETE business and technical training PLUS the needed equipment to enter business at once for full or part time profits—or to start off on a career in any one of Radio's specialized fields such as Public Address, Auto Radio, Commercial Radio, Broadcasting, etc.

READ WHAT OTHERS SAY ABOUT THE FAMOUS SPRAYBERRY TRAINING

A. H. LANOIE, Northbridge, Mass., writes: "Since enrolling I have cleared a net profit of more than \$150 in spare time alone . . . and I am not half through the course yet. Honestly, I cannot understand how you can give so much for so little money."

EDWIN A. GAMMON, Auburn, Maine, says: "Due to your course I have been deluged with work . . . achieving good results with radios which had been unsuccessfully tackled by other service men. You deserve all the credit."

WALTER DAVIS, Baltimore, Md., enthuses: "Thanks to the Sprayberry Practical course, I am now making on an average of from \$10 to \$25 per week in spare time work."

I CAN TEACH YOU QUICKLY—NO PREVIOUS EXPERIENCE REQUIRED

No matter what type of work you have been doing . . . no matter how limited your past experience in Radio . . . my practical, home study course will thoroughly fit you for a useful and profitable career.

You will be amazed at how quickly you will grasp the fundamentals of modern RADIO . . . it is really very easy to learn. My course has been planned to give you just what you need. It's easily understood . . . the best TRAINING value you will find anywhere in the country. Write today for my latest FREE booklet, "YOUR FUTURE IN RADIO."



YOU GET THIS PROFESSIONAL EQUIPMENT

SERVICEMEN! For those already in Radio, Sprayberry offers an ADVANCED Training Course that has proved invaluable to hundreds of servicemen. Saves you time—saves money—teaches you the easiest way to do the hardest jobs. Get details. Mark an X here () and we will send our ADVANCED Radio Training Booklet free.

SPRAYBERRY ACADEMY OF RADIO

F. L. Sprayberry, President, 2544 University Place, N. W., Washington, D. C. WITHOUT obligation on my part please send your Free book "YOUR FUTURE IN RADIO" and other details of famous Sprayberry Training.

Name

Address SWC 12/36

Paste this coupon on a penny postcard and mail TODAY.

The one and only Encyclopedia on Short Waves, by C. R. Leutz and R. B. Gable. Now \$1.00. (Plus 15c postage in U.S.) Formerly \$2.98. Radio Publications, 103 Hudson St., N.Y.C.

RADIOS WHOLESALE!

5 TUBE **695**

30 DAYS TRIAL

Tune in on politics, news, music, market and weather reports with a new ZEPHYR WORLD-WIDE RADIO. All the latest improvements. MONEY-BACK GUARANTEE, one year FREE service.

All electric, farm, battery and auto radios, buy direct and SAVE UP TO 50%. Ask about our User-Agent Plan. EARN EXTRA MONEY, be a ZEPHYR salesman.

ZEPHYR RADIO COMPANY
13135 Hamilton Ave., Detroit, Michigan

Write for FREE Illustrated Catalogue

1937 RADIO PARTS CATALOG

Showing The Latest RADIO EQUIPMENT FOR THE DEALER THE SERVICEMAN AND THE AMATEUR

Our New Catalog just off the Press Write for your free copy—Now!

CAMERADIO

601-3 GRANT ST., PITTSBURGH, PA. • 30 TWELFTH ST. WHEELING, W.VA.

Established 1919

Please mention SHORT WAVE CRAFT when writing advertisers

H. G. CISIN'S 1937 METAL TUBE JR. SPACE EXPLORER



4-TUBE MODEL 6-B 9-560 METERS

COMPLETE KIT—high quality Find-All parts including Loud Speaker, diagram, instructions (unwired, less tubes, coils, cabinet)

\$6.95

Four Find-All Short Wave Coils — \$1.65.
Two Broadcast Coils—85c. Special Long Wave Coil with I. W. Unit—95c. Set of Four Matched Tubes incl. K-105-A—\$2.95.
Two ornamental Rings for Panel Front 25c each.

CERTIFIED FOREIGN RECEPTION

SIX bands, range 9 to 560 meters continuous coverage—also long wave to 1500 meters if desired. Self-contained power supply and full-toned quality speaker. Phone Jack at front. Antenna Control. Dual Regeneration control. Metal 6J7 pentode regen. det.; metal 6C5 1st audio; newest metal tube K-105-A Ballast; 28 power output pentode. Full-vision triple calibrated dial; Precision Instrument type Bar Knob. Operates a.c. (any frequency) or d.c. Cisin Circuit Patent pend. No. 592,586. Easily built—no dual purpose tubes to complicate wiring. Wood cabinet easily made saves cost of metal and gives superior tone quality. Full directions with kit.

H. G. CISIN, CHIEF ENG., ALLIED ENGINEERING INSTITUTE
DEPT. S-31 38 PARK PLACE NEW YORK, N. Y.

Grid Bias—How and Why

(Continued from page 480)

that to bias a tube we must make the grid negative with respect to cathode. It follows that we might obtain the same results by making the cathode positive with respect to grid. A resistor in the cathode circuit of a tube gives the cathode a positive potential, thus affording the necessary bias. The grid is allowed to remain at zero potential.

Let us examine the workings of the cathode resistor in Fig. 2. The plate current of the tube flows through the resistor causing a *voltage drop*. Therein, the plate circuit from negative B to positive B might be likened to a bleeder circuit, in which the cathode resistor, the tube itself, and the plate load (L1) form the whole resistance. Consider the cathode as a tap in this bleeder circuit; in this light it is easy to understand why the cathode becomes positive. Since the grid remains at zero potential, the effective bias on the tube will be equal to the positive charge on the cathode.

Whenever using this type of bias it must be remembered that any audio or radio frequency components must flow through the cathode circuit. It is therefore necessary to by-pass the cathode resistor with a condenser large enough to pass the frequencies being handled. In audio circuits 25 mf. is an accepted value, and .1 mf. is adequate for radio frequency.

The correct value for any cathode resistor can be determined from Ohm's law. Any tube table tells the plate current of a given tube. Knowing I (plate current) and E (bias required) merely solve for R. In the case of multi-element tubes, I will be the *total current of all plates and screens*. This is true because the current to each element must flow through the cathode resistor.

Grid-Leak Bias

Perhaps the most complicated bias system is the simple little grid-leak. Since grid-leak bias (Fig. 3) will work only on tubes whose grids swing positive, its use is limited to *oscillator circuits and neutralized amplifiers* that receive steady excitation.

When the grid of a tube is driven positive, it attracts some of the negative electrons leaving the cathode. When the grid swings negative on alternate half cycles of oscillation, the positive charge gets a chance to dissipate; but the negative charge remains. The only path for these negative electrons is through the grid-leak to ground and, since the grid leak is a very high resistance, a negative charge builds up on the grid. Furthermore, its value may be varied by changing the value of the grid-leak.

Although the grid assumes a negative charge instantly, it must be remembered that the grid must first be driven positive to begin this action. And it must continue to be supplied with positive half cycles to keep up the action. Therefore, only oscillating circuits and excited amplifiers may be biased by means of a grid-leak.

Fixed Bias

A fourth type of bias has gained favor recently. It is closely related to cathode bias, in that the bias voltage is secured through *voltage drop* across a resistor. However, the biasing resistor is then a part of the bleeder (See Fig. 4). This creates a negative charge on one side of the resistor with respect to ground or B—. Since the *voltage drop* is controlled by bleeder current as well as plate current, the bias voltage is much more stable than ordinary cathode bias. This method is most useful in circuits where the plate current is subject to variations, as in Class A-B audio stages.

In conclusion, one method is as good as another if each is adjusted properly. With the exception of grid-leak bias, which has limited uses, all methods are interchangeable. In checking bias voltages, a high resistance voltmeter should be used; however, this can not be done in the case of grid-leaks because the meter itself will greatly affect the value of the leak and the reading will mean nothing.

READ Like an Expert SEND CODE

Learn Quickly at Home—Get Real SPEED



It's easy, fascinating, to become a good op with the NEW ALL ELECTRIC MASTER TELEPLEX Code Teacher to help you. Only instrument ever produced which records your sending in visible dots and dashes—then sends back to you at any speed you desire. Also sends practice work, recorded by an expert. That is why so many schools teaching code prefer Master Teleplex. That is why thousands agree this method is surest and quickest. Teleplex has been teaching the code exclusively for many years—longer than anyone else. We furnish Complete Course, lend you Master Teleplex, give you personal instruction with a MONEY-BACK GUARANTEE. Low cost. Send today for booklet S12; no obligation.

The "HAM" Standard Teleplex—A highly efficient code teacher using heavy specially prepared waxed paper tape, having two rows of perforation. Write for Free folder "SW12"

We are the originators of this type instrument

TELEPLEX CO.

72-76 Cortlandt St. New York City
TELEPLEX—"The choice of those who know"

BUD Use Bud Chassis, Cabinets and Relay Racks for your Receiver, Transmitter, Amplifier and Test Equipment.



Write for Catalog which illustrates the largest assortment of this merchandise.

BUY FROM YOUR JOBBER

He stocks a good assortment of BUD merchandise.

BUD RADIO, INC. 1937 E. 55th St. Cleveland, Ohio

Fixed Condensers Made from Coils of Wire

(Continued from page 480)

cause trouble in high-frequency circuits.

To overcome the first snag we coil up the length of condenser on a pencil or 1/4 in. curtain rod. That brings the length of the condenser mentioned down to about 2 in. and then it can be connected right into the circuit without any external wiring—a neat and compact little gadget.

To overcome the inductive effect we have to alter the method of winding. First of all, wind on half the length of twisted wires in a clockwise direction and then, when you get to the end of the first half, knock a little tack into the former and wind the wire onwards but in the opposite—that is *anti-clockwise*—direction.

Self-supporting Condenser

When this has been done you take out the tack and slide the coiled wire off the former—the tack having kept the wire taut and the resulting coiled condenser being quite self-supporting. Remember that one end must have the two wires cleaned off for contact, whereas the other end must just be cut; on no account must the two wires be allowed to touch.

These remarks apply to the making of all the condensers shown in the main group by the drawing, except the .000012 microfarad condenser. This little condenser is intended for use as an aerial pre-set in a short-wave receiver. It is not non-inductive—as this hardly matters for the purpose in mind.

With this system it is not practicable to go much bigger than .0002 microfarad because the actual formation of the wire becomes rather straggly.

But it is possible to make a bigger capacity condenser by using a slightly different method.

We only recommend this type for use as by-pass condensers on the low-frequency side and so on.

Nearly everyone has a piece of small threaded rod on hand, which forms one plate of this second type of condenser. To make a .0003-microfarad, use a piece of rod 2 1/2 in. long and wind on it 100 turns of 36-gauge D.C.C. wire. Simply wind the wire in the threads of the rod, so that there is only a very small gap between the wire and the rod. You only use about 2 ft. of wire—getting the high capacity from the fact that the rod at the centre and the wire round it are so close together.

One contact is the rod—solder on to that. The other contact is one end of the wire—whichever you like. Fix this by a piece of insulation tape.—*Amateur Wireless.*

Please mention SHORT WAVE CRAFT when writing advertisers

Short Waves, Plus Strings, Guide Planes

(Continued from page 463)

aircraft within its district. This may cover an entire province. Every airplane, as it enters a new district, reports by radio to the official in charge of the radio transmitter.

In the ground office, the course and altitude of the aircraft are recorded on the chart whenever the weather is poor. Directions sent out by radio to all aircraft aloft within this district, prevent any interference with each other or any chance of collision. If the pilot is unable to report his position closely he is able to obtain his bearings by calling upon two ground-stations. His position is then plotted on a locating chart and communicated to the flyer. It is done in this manner. Several ground stations report the direction in which they have signalled an airplane to proceed. The ground stations are indicated on the chart by means of white-headed thumb-tacks. A string is laid out in the direction that has been determined, the end of the string being weighted. The point at which several such strings intersect, indicates the position of the airplane at the moment! This position is then radioed to the flier. The telegrams are sent in code. Through this method, landing in bad weather, even ceiling zero weather, is accomplished.

An official in charge of the ground-station pilots the machine with the aid of the apparatus to determine and communicate bearings. He is in constant touch with the observer who sits with his fingers on the keys of the ground radio and locating station. In this manner, he can reroute the airplane on its proper course and bring it safely to land.

Recently, with the aid of short-wave landing beacons, a rigidly indicated landing course is communicated to the incoming aircraft, which receives the sender's signals. At distances ranging from 900

The Radio Operator's Dream Comes True!



The Receiver You've Been Waiting for IS HERE!

A small compact unit in a neat, attractive cabinet. Speaker, power supply, everything self-contained. Covers every wavelength from 9.7 to 20,000 meters with smooth, easily controlled regeneration all the way. No dead spots or gaps. Pleasing tone, exceptional selectivity and extreme sensitivity, combined with quiet operation and almost non-existent noise level. Dial calibrated over the entire tuning range. Band spread dial calibrated for amateur bands.

Sounds too good to be true, and it was until Model 11 was designed. Recent engineering developments plus our own background of radio experience extending over 25 years and including years of brass bounding on the high seas made it possible for us to perfect this real RADIO OPERATORS' receiver.

- Coil Switching
- All-Wave Band Spread
- Built-in Power Supply
- Jensen Dynamic Speaker
- R.C.A. Tubes
- Fully Calibrated Dial
- Phone Jack
- Break-in Switch
- R.F. Gain Control
- Regeneration
- Antenna Trimmer
- Large Knobs

Model 11 is ruggedly built, and will last for years. It is a pleasing receiver to operate—the more you use it the better you will like it.

PERFORMANCE

SHORT WAVE C.W. Low noise level, high selectivity and sensitivity make it outstanding for C.W. work. Will pick up readable signals lost in noise level on most sets.

SHORT WAVE PHONE AND BROADCAST. An excellent performer on both of these. Pleasing tone, free from "blasting."

AMATEUR BANDS. High efficiency on all of them.

SHORT WAVE SHIP BANDS. Outstanding on these. Brags them in from "south of Pernambuco," "west of Penang," and "east of Gibraltar."

POLICE CALLS. Holds the

Model 11 Net Prices for 110 V. 60 cycles operation

Model 11-UNIVERSAL tuning range, 9.5 to 20,000 meters.....\$75.00

Model 11-MA. MARINE tuning range, 9.5 to 3,750 meters.....\$54.00

Model 11-A. AMATEUR tuning range, 9.5 to 550 meters.....\$46.00

Prices include power supply, speaker and R.C.A. tubes. IMMEDIATE DELIVERY.

Model 11 is available in all A.C., D.C., and battery voltages.

Write for full description.

E. M. Sargent Co., 212 9th Street Oakland, Calif.

to 2700 feet from the boundaries of the landing field, small short-wave landing signal transmitters are stationed. They indicate the distance from the airport so that the aircraft can prepare for its landing in plenty of time.

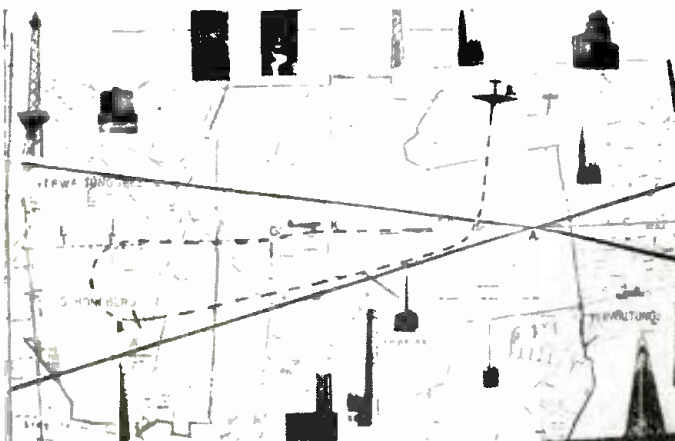

Top photo shows the diagram representation of the route to be observed by a plane or airship previous to its landing. During this period the plane must remain between the heavy black lines, when over Berlin, to avoid approaching any high buildings. It is enabled to recognize this space by the waves it receives from the radio beacons. In case of fog, the machine receives orders from the ground advising the pilot when he should attempt a landing. Lower photo shows loop aerials on the roof of the Tempelhof ground station. By rotating these loop antennas, it is possible for the operator to determine the direction from which the radio message sent by an airplane originated.



AC CURRENT ANYWHERE!

On FARMS—In D.C. Districts—In CARS with ATR DC-AC INVERTERS

List Price \$18.50*

*Without Radio Filter \$22.50 with Built-in-Filter—Standard discounts apply

Proven—Dependable—Guaranteed

Outstanding Features: Interference Free All Wave Radio Operation • Improved Long Life ATR Vibrators • Four-Point Voltage Regulators • 16 different types for DC Input Voltages ranging from 6 to 220 volts and having AC output voltages of both 110 and 220 volts.

ATR Auto Radio "A" BATTERY ELIMINATOR

Dealers' \$12.95

Net Price

Specially designed for demonstrating and testing auto radio sets on regular AC lines, 105-125 volts, 50-60 cycles. Has many other uses. Comes completely equipped with on-off Switch, Pilot Light Indicator, 10-ampere Fuse, Rubber Mounting Feet, 6-ft. Rubber Cord, Heavy Gauge Metal Cabinet.

ATR Automatic Tapering Battery Charger

Keeps Auto Battery Fully Charged Right In The Car! Operates from any 110 volt AC 50-60 cycle line. Equipped with a full wave dry disc type rectifier unit. 4 urethane plates of an battery becomes charged. Comes completely equipped with isolated dash receptacle and plug lines, 9 feet 1st cord, 12 feet AC cord, on-off master switch and complete instructions.

LIST PRICES (Standard Discounts Apply)

Model 450. Max. charging rate, 4 1/2 amp. \$9.67. Model 600. Max. charging rate, 6 amp. \$11.45. Model 1000. Max. charging rate, 10 amp. \$14.25.

Write or Wire for Additional Information Sold by Leading Jobbers Everywhere

AMERICAN TELEVISION & RADIO CO. St. Paul, Minn., U.S.A. Cable: "Likex" New York

Please mention SHORT WAVE CRAFT when writing advertisers

POWER LINE NOISE ELIMINATOR



The same principle used in our own Laboratory screen rooms—a balanced filter containing noise-blocking inductances and noise-by-passing capacities. Completely BLOCKS OUT power line noise! Fully assembled \$7.20 net.

R9+ TUNED ANTENNA

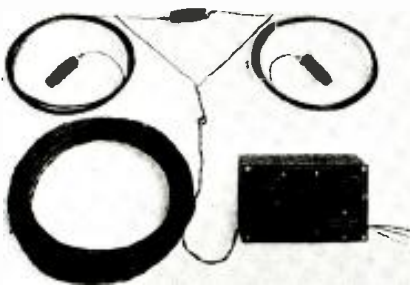

Beginning where all other antennae leave off. Brings to listeners a new era in short-wave reception. In practical tests the new R9+ has increased short-wave signal volume from three to six times over present antenna equipment. Fully assembled \$8.85 net.

McMURDO SILVER CORP.
Division of G.P.H., Inc.
1711 ROSCOE ST., CHICAGO, ILL.

Low Wholesale Prices BIG FREE CATALOG



Over 10,000 items in this big catalog including radio receivers, nationally known radio parts and broadcasting equipment at lowest wholesale prices. A catalog of great value to dealers and servicemen. Write for your FREE copy of this big catalog today.

BURSTEIN-APPLEBEE CO.
1012-14 McGee St., Kansas City, Mo.

RELAYS

110 VOLT AC, 60 CYCLE, 30 AMP. CONTACTS
IDEAL FOR CONTROLLING YOUR XMITTER

Code No.	Pivot Type with Shlp. Wt.	Price
1—Single Pole	1 break—1 make 1 pds.	\$1.50
2—Double Pole	2 break—2 make 2 pds.	2.00
3—Triple Pole	3 break—3 make 4 pds.	2.25
4—Four Pole	4 break—4 make 4 pds.	2.50

These relays were used for Laboratory Model work and are in perfect condition throughout. The quantity is limited and subject to prior sale. These prices are about 1/4 of actual cost when new. Send 25% with order, balance C.O.D.

ARROW SALES CORP.
631 Washington Blvd. Chicago, Illinois

CABINETS

Made to your specifications

Send drawing or blue print for our estimate.
KORROL MFG. CO., Dept. S-12,
232 Greenwich St. New York City

Let's Listen In With Joe Miller

(Continued from page 484)

careful tuning in the region of XQJ's frequency on ur dial. You can't miss that Asiatic "flutter" on these sigs!

For all of these stations, reports should be addressed to the Chinese Gov't. Radio Administration, Sassoon House, Jinkee Road, Shanghai, China, and a good report, with a reply coupon, will elicit for you one of your best veries!

Ashley Walcott, San Francisco, Cal., forwards additional dope as follows: the Shanghai-Hangkow telephone circuit uses several different frequencies during the morning. From about 3 to 4:15 a.m. Shanghai is on 11.41 mc., and Hangkow is on 11.70 mc. Between 6 and 7 Shanghai is on 9.285 mc. and Hangkow on 9.08. Once between 8 and 9 a.m. Shanghai was coming in with a good signal on 3.49 mc. and Hangkow with an excellent signal on 3.27 mc. More recently, Shanghai has been on 5.72 mc. with tremendous volume from 8 to 10 a.m. Hangkow is always somewhat stronger than Shanghai, though both are good.

XGOX, Nanking, China, relaying XGOA is on 6.85 mc. daily from 6:30 to 9:00 a.m. with programs of Chinese and European music, and news given in English at 8:05 a.m. Volume is excellent.

Sumatra

YBG, 10.43 mc. at Medan. is occasionally heard phoning PLV, which station relays YBG's message to Europe, generally. YBG once heard calling Berlin, a good R7-8, while PLV, relaying YBG, was only R5, despite its 80 KW! PLV sometimes sends music just before 5:30 a.m., to begin their contact with YBG. As given in last issue, the YBG-PLV sked is daily 5:30-6:30 a.m., when there is traffic to be carried.

Fiji Islands

VPD on 13.075 mc. is no more. In its place is VPD2, on 9.54 mc. and the schedule is now changed to 5:30-7:00 a.m. daily except Sunday. This station is really well heard, averaging R7-9, but the modulation is still very poor, making VPD2's programs anything but enjoyable. Ashley Walcott says "The programs are all sponsored by Australasian firms, investment houses, shoe stores, anything!"

Indo-China

Philco Radio, Saigon, Indo-China, is being heard on the West Coast on 11.70 mc., according to Ashley Walcott of San Francisco. This station has been reported under various calls, but there has been no definite information as yet, so we list it merely as "Philco Radio." Here's the rest of dope: announcements in French and English, operating morning till 9:30 a.m., signing off with a march recording.

Reports, if you're lucky enough to snare this FB catch, are to be addressed to P. O. Box 295, Saigon, French Indo-China.

Egypt

SUV, 10.05 mc. one of the three famous Egyptian fones, located at Cairo, has been heard several times last month, at 4 p.m., and again at 6 p.m. This station has never been heard with a strong signal here, but can be identified by their unstable carrier wave.

SUZ, on 13.83 mc., a sister Cairo station, is about the easiest of the Egyptians to hear and can be heard almost daily, phoning GBB on 13.50 mc. Here's how: look for both these stations just before 11 a.m. sharp. If you hear steady whistles on carriers approximately where you'd expect these stations, hold on to GBB's powerful carrier and at 11 a.m. sharp you'll hear GBB call, "Hello, Cairo." Immediately tuning to the other whistle, you'll hear SUZ reply to London, "Hello, London." After a few words these usually go into scr (scrambled) speech. SUZ also heard foning GBB at 1:45 p.m. one afternoon.

Have YOU Tried DATAPRINT



SERVICE?

These NEW Prints show you How to Build Electrical Apparatus!
New low price—
Any 3 Prints...\$1.00

Can YOU Fry Eggs on a Cake of Ice?
Data50c

TESLA COIL DATA:

Dataprint—drawings and data for building 20 inch spark Tesla.....50c
Exciter—1 K.W. 20,000 Vt. Transf.....50c
3" Sp'k. Tesla Coil, Works on Fan.....50c
3" Sp'k. Oudin Coil, Works on 110.....50c
20 "Tricks" with Teslas & Oudins.....50c
4" Sp'k. Tesla Coil.....50c
Exciter—1 K.W. 15,000 W. Transf.....50c
Violetta—1" Sp'k. Oudin, Vibrator type.....50c
How to Operate Oudins from V. T. Osc.....50c
WELDING
Electric Welding Trf. 2 K.W. 110 V. Prim. 18 V. Sec.....50c



S-W DIATHERMY (Artificial Fever)

Dataprint, Constructional data for Small, Medium and Large size App... 50c

Magnets & Solenoids!

Data only—50c per print.
A—Powerful Battery Magnet, lifts 40 lbs.
B—110 V. D.C. magnet to lift 25 lbs.
C—110 V. D.C. magnet to lift 300 lbs.
D—110 V. D.C. Solenoid, lifts 2 lb. thru 1 in.
E—110 V. D.C. Solenoid, lifts 6 lb. thru 1 in.
F—12 V. D.C. Solenoid, lifts 2 lb. thru 1 in.
G—110 V. A.C. Solenoid; Powerful (60 cycle.)
A.C. MOTOR—
1/16 H.P. "Easiest to Build"—110 V. 60 cy. A.C. Data50c

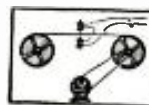

RECORD PROGRAMS on Steel Wire!
Telephonograph Data, for Voice or Code.....50c

Induction PIPE & ORE LOCATOR

Construction Data.....50c



20 ELECTRIC LODGE & PARTY TRICKS. Fun Galore!

"How to Do 'Em" Data 50c

RADIO CONTROL for MODEL BOATS, etc.

Circuit data.....50c



More DATAPRINTS You Need!

50c each Prepaid.....3 prints for \$1.00
Water Turbines
Water Wheels
Motor Circuits (20)
Telephone Hook-ups (20)
100 Mechanical Movements
Polarized Relay, Ultra-sensitive
Shocking coil
Ring 1 bells on 1 circuit
20 Simple Bell Hook-ups
Public Address System
Electric Chime Ringer
Hits any clock
60 or 1200 cycle Synch. Motor
"Rewinding" Small Motor Armatures.....\$0.50
Induction Balance
Tautograph
Einhornen String Galvanometer
Electric Fan Motor
Watch Demagnetizer
Electric Furnace Draft Regulator
Building a Simple Telephone
Ignition Coil Data
Electric Tube Thawer
Wheatstone Bridge
Induction Coils—1 to 12 inch Sp'k. data
"Rewinding" Small Motor Armatures.....\$0.50



SLIDE RULE—4" Metal

Price \$2.00 Net.
With Case and Instructions, Multiples, Divides, Adds, Subtracts. Gives Roots, Powers, Sines, Cosines, etc. Also Logs of Numbers. Approved by colleges. 8" Dia. 25" Scale "Special Rule." \$5.00 Net.

The DATAPRINT Co.
Lock Box 322 RAMSEY, N. J.

Reports on the Cairo phones should be addressed to P. O. Box 795, Cairo, Egypt. These stations are very prompt in verifying reports, always taking five weeks for a veri.

Siam

Ashley Walcott again sends us some FB news. HS8PJ, on 9.35 mc., is on the air every Thurs from 8-10 a.m. Ashley heard HS8PJ say that Siam is also on 19.02 mc. every Monday from 8-10 a.m., also. This makes three Siamese now broadcasting regularly, if our dope is correct, as HS8PJ, 10.955 mc., is also listed as on the air Mondays, 8-10 a.m. We would suggest trying for HS8PJ on 10.955 mc. on Sundays from 8-10 a.m. also. We wonder, however, if HS8PJ is equipped to B.C. simultaneously on both 10.955 and 19.02 mc., as both are supposed to be on 8-10 a.m. Mondays.

HSP, the commercial fone at Bangkok on 17.74 mc., was heard one morning phoning at 5:30 a.m. This station is rarely heard, however, HSP usually phones Berlin or Tokio, occasionally Saigon. Full skeds given in previous issue.

Manchukuo

JZB, or TDE, on 10.065 mc., located at Shinkyo, is being heard quite often, last being heard here at 5:30 a.m., foning its usual contact station JVO, Nazaki, on 10.37 mc. Usually, only the carriers of these stations are heard, and are on daily anywhere from 3 a.m. up to as late as 8 a.m. or so. Much patience in holding on to these sigs is required before one has the good fortune to hear them foning one another.

As the EHZ-EDN circuit is probably not in operation for the present, if you hear "fluttering" sigs, with JZB's the louder, you can be quite sure the signals are those of JZB-JVO.

A veri of TDD, 5.83 mc. gives the following dope on JZB-TDE: JZB, 10.065 mc. is on every Saturday from 10:50-11:30 p.m., broadcasting to Japan.

The QRA of the Manchukuoan stations is: Kanjoshi Xmitting Station, Manshu Denshin Denwa Kaisha, Shinkyo, Manchukuo.

Algeria

Algiers on 8.96 mc. is often heard foning TYA2, 9.04 mc., usually about 12:30-1:30 a.m., and occasionally about 4-5:30 p.m. Algiers is very strong, steady, and uses side-band secrecy for all traffic.

U.S.S.R.

RKI, Moscow, 15.145 mc. once called Alma-Ata, RWJ, 12.18 mc. at 11.56 p.m. A woman was heard counting 1-7 in Russian.

RIR, Tiflis, 10.08 mc. is reported foning Moscow almost daily from 9-11 a.m., by Ashley Walcott.

Here's an offer from Moscow that sounds interesting!

"Beginning from October 1st we will dispatch to each listener who writes to us a copy of any radio talk they desire, and every tenth letter opened will get our well-known illustrated journal USSR IN CONSTRUCTION. In addition, every new listener who writes to us will receive a photo of a well-known Soviet leader, pastcard views of Moscow and the U.S.S.R., or some of the latest Soviet stamps."

Java

YDC is putting in a FB signal on 15.15 mc. from 4:30 a.m. on, relaying the regular NIROM programs.

Ashley Walcott forwards some data on Javanese stations—a station on 6.72 mc. probably PMH, is relaying native NIROM programs from 5:30 a.m. up to as late as 10:30 a.m. and heard very well in California. Ashley adds that these programs on 6.72 mc. are not the same as those heard on YDB or PLP, but are probably those of a local, native network.

Ashley also reports a Manila fone, KAX, on 19.98 mc. calls ZGB, at Kuala, Lumpur, Federated Malay States, at 7:55 p.m., approximately. The frequency of ZGB is as

THE SKYROCKET!

**5-tube Universal Receiver
1 1/2 to 600 METERS
A SENSATION
EVEN AMONG the STARS!**

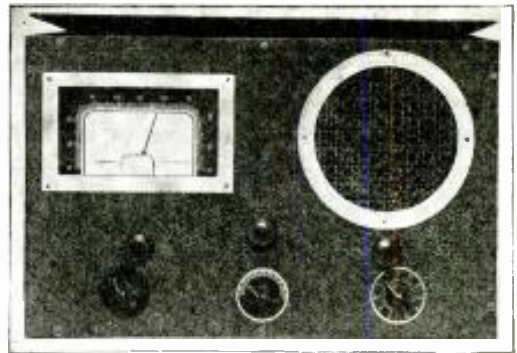

THE KING OF THEM ALL!

Dollar For Dollar, This Is The Greatest Radio Value. We Believe, That Has Ever Been Offered To The Short Wave Fan. A big, powerful radio with a tremendous Tuning Range. A unique dial with plenty of bandspread and look at its size! Band switching from 15 to 600 meters. No plug-in coils—just snap a switch and there, at your finger tips, are all the thrills that radio can offer: Short wave foreign stations, ship to shore conversations, inter-continental telephones, aeroplanes, police, amateurs, experimental television, Apex stations, direct pickups of sport events on the ultra-high frequencies, etc., etc. And finally, the regular long wave broadcasting stations with a good dynamic speaker to reproduce the programs for you. (Note: The ultra-high frequencies, below 15 meters, are handled by a separate built-in high frequency tuning unit using a ceramic insulated three plate tuning condenser and self-shielding interchangeable coils.)

Electron Coupled Regeneration Plus Super-Regeneration

The SKYROCKET uses a carefully developed and engineered circuit consisting of one stage R.F. amplification, two

detectors (regenerative and super-regenerative) and the new 25H07 power amplifier tube with its large, low harmonic distortion output. The new Sylvania 6L5G high frequency tube is used as super-regen. detector.

The most successful of the regenerative circuits has been adopted, utilizing the 6K7 metal tube as detector with double regenerative control, while another 6K7 serves as a stage of untuned R.F. amplification.

THE SKYROCKET KIT: complete with drilled panel and chassis, wired switch-coil assembly, power pack, high frequency tuning assembly, dynamic speaker, etc., less tubes and cabinet, unwired, **\$11.95**

Metal Cabinet, black crackled finish, **\$2.50**
Five tested Sylvania tubes, **3.85**
Assembly, wiring and testing, **3.00**

SPECIAL COMBINATION PRICE ON COMPLETE SKYROCKET: Well tested and guaranteed for one year; ready to plug in to 110 volt outlet (either A.C. or D.C.) and operate, with 5 tubes and cabinet, **\$19.95**

IMPORTANT!

THE SUPERIOR INSTRUMENTS COMPANY with their past record of exclusive service instrument design and manufacturing experience has at last decided to enter the radio receiver field. To warrant this step their first set would have to be something unusual in both performance and value. Determined to use their facilities and experience to produce the most radio for the least possible money, without sacrificing quality, they made a study and analysis of the all-wave receiver field and frankly adopted the best features of everything they found! The SKYROCKET is the final result.

The experienced radio experimenter is bound to acclaim it as the MOST SENSATIONAL VALUE IN RADIO TODAY!

SUPERIOR INSTRUMENTS COMPANY

139 CEDAR STREET
DEPT. S-12
NEW YORK, N. Y.

WHAT TO MAKE and how to make it ON A LATHE

WRITE for these books: (1) The HomeWorkshop, free; (2) What to Make on the Lathe, 10c; (3) How to Run a Lathe, 100 pages, 25c. Coin or stamps accepted. Any South Bend Screw Cutting Lathe on easy terms. Priced \$75 up. Ask for Catalog 15, free.

SOUTH BEND LATHE WORKS
371 Madison St., South Bend, Indiana, U.S.A.

Guaranteed 40 Powers Long Distance Telescope \$2.48

New Model! Greater Illumination
Clearly bring distant objects close to your eye. Easily see far away subjects magnified with this TESTED Super 40 Power Telescope. Look from your roof or out of your window and far away sights become as clear as if you were on the spot when focused with this TESTED SUPER 40 POWER TELESCOPE. See the moon, stars, ships, sport events, etc. Can also be used as a microscope for scientific observation. Have fun with far away neighbors. Look at what they are doing and phone and tell them about it. They will wonder how you know... makes objects miles away appear in front of you. A scientific achievement that defies competition. Durable! Made of brass bound 4 powerful lenses. 1 foot long, closed, about 3 feet open. Made in U. S. A. SPECIAL FREE OFFER. Order at once! We include a genuine pocket telescope that closes to two inches. Fill out pocket! Great for emergency! **SEND NO MONEY!** Pay postman \$2.48, plus postage, or send \$2.48 now and we will mail you. Outside U. S. A. \$2.98 Cash with Order.
J. H. Winn Mfg. Co., Dept. T-912, 124 W. 23 St., New York

PATENTS—TRADE MARKS
All inventions submitted held confidential and given personal attention by members of the firm.
Form "Evidence of Conception" and instructions
"How to Establish Your Rights"—Free
LANCASTER, ALLWINE & ROMMEL
PATENT LAW OFFICES
475 Bowen Bldg. Washington, D. C.

SPECIAL FOR THIS MONTH
Send \$1.00 (\$1.25 Canada and foreign) and we will send you SHORT WAVE CRAFT for Eight months. "DO IT NOW!"
SHORT WAVE CRAFT, 99-101 Hudson St., New York

Experimenters NEED—

ICA CHROME SILVER DIALS
With Finger-Grip Flange Knobs

Beautiful chrome silver dial plates accurately Engraved with black numerals and calibrations. Mounted on ICA Finger-Grip Flanged Knobs. Calibrated for 180 degrees and 325 degrees.

No.	Size	Degrees	Vol.	List
2170	2 1/2"	325	0-100	\$1.25
2171	2 1/2"	180	0-100	1.25
2168	4"	325	0-100	1.75
2169	4"	180	0-100	1.75

New and Improved ICA CRYSTAL HOLDERS

Made of Inulite, a moisture-proof ceramic compound having extremely low loss dielectric characteristics. Electrodes are solid brass wire-welded to uniform pressure. Furnished with metal cover and sturdy banana plug contacts.
For 80 and 160 Meters—Suitable for use with crystals covering from 40000 Kc. to H.C. frequencies. **\$1.50**
No. 414, List **\$1.50**
For 20 and 40 Meters—Recommended for crystals covering frequencies from 14 M.C. to the H.C. band. **\$1.50**
No. 418, List **\$1.50**

Send 10c in coin or stamps for our latest descriptive catalog. ICA items available at your Jobber, or write us direct.
INSULITE CORPORATION OF AMERICA
25 Park Place, Dept. S-12, New York City

SPECIAL

America's Outstanding Microphone Value!
Amateurs—Public Address and Sound Equipment men—here is what you get in this amazing offer!
1 Lifetime No. 6 D.B. Mike. List \$8.00 Sold separately at **\$2.95**
1 Lifetime No. 6 Stand and springs **\$1.75** Sold separately at **\$1.75**
1 Lifetime Shielded Matching Transformer **\$1.45** Sold separately at **\$1.45**
1 Lifetime 8 Foot 3 conductor shielded cable sold separately at **45c**
LIFETIME Model No. 6 Double button microphone is ruggedly constructed—finished bright aluminum polish. Is 3 1/2" diameter and 1 1/2" thick overall. Has gold spot duriumium stretch diaphragm, gold contact buttons, finest carbon granules and has frequency response between 40 and 3500 c.p.s. Order direct from manufacturer and save MONEY.
THE LIFETIME CORPORATION
1008 Madison Ave., Toledo, Ohio
Manufacturers: Microphones, Carbon, Condensers, Crystal, Velocity and Dynamic, Aluminum Trumpets, Electro Dynamic Units, Batteries, complete P.A. and Sound equipment. Write for catalog.

Please mention SHORT WAVE CRAFT when writing advertisers

RADIO INSTRUCTION

LEARN CODE at Home with the CANDLER SYSTEM



CANDLER Trained McElroy, Champion Class A. Sneed 69 wpm.

CHAMPION McELROY who teaches CANDLER SYSTEM at HARVARD, says: "Practice alone, of any kind, will not develop skill and speed. It takes a thorough knowledge of the fundamentals and Mind Training, taught exclusively by THE CANDLER SYSTEM."

Those speedy operators you hear on the air are mostly Candler trained. With the Candler System you can improve your operating speed in an amazingly short time right at home.

This system teaches you code by sound, the only correct and accurate way. With only a few hours of practice the Candler way, you will see an amazing development in your performance. In a few weeks' time you'll be pounding brass with the best of them.

And it's easy—your lessons are a pleasure, not a disagreeable chore. You'll actually enjoy your practice period, especially when you see such astonishingly rapid development.

Send today for the FREE Candler "Book of Facts" telling you all about this remarkable system of code instruction. Read how the champions gained their amazing speed. Advanced courses for operators who want to get their commercial license. Get full information today.

No Expensive Practice Equipment Needed

CANDLER Will Train You In Everything Necessary To Obtain Your License.

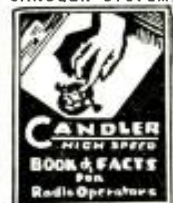

CANDLER SYSTEM
Dept. SW-12 Asheville, N.C.

Be a TELEVISION EXPERT

LEARN TELEVISION with RADIO—NOW!

Great opportunity for experts in this amazing new industry. Recent developments in radio make television a certainty NOW. We teach you by our "on the job" method Radio and Television from beginning to end in our marvelously equipped labs and studios. You actually operate thousands of dollars worth of expensive equipment. You get expert instruction and skillful guidance by radio-television specialists.

Demand for Television Experts
Television now perfected and ready for the market ON THE NEXT BIG BUYING WAVE. Business leaders predict new system television will require thousands of relay and broadcasting stations. Ultra-short waves will permit eighty thousand television stations in America alone.

GET IN NOW and "build up" with the world's next billion-dollar industry. **8 MONTHS THOROUGH PRACTICAL TRAINING** Qualifies for radio-telephone license (14 Class). Complete up-to-the-minute training in modern "workable" tele-voice equipment including the new cathodray. Practical experience in studio control room. Transmitter operation of Television Station W5XAL. Employment and while training and upon graduation. Write for free book "Pictures On the Air" NOW!

S. Q. NOEL, Pres. First National Television, Inc.
Dept. B-12, Power & Light Bldg., Kansas City, Mo.
Without obligation, send me postpaid FREE Illustrated Book—"Pictures On the Air", telling about new opportunities in television. I am 17 years or older.

Name.....
Address.....

Learn TALKING PICTURE PROJECTION SOUND RECORDING TELEVISION-RADIO

Quality for Good Jobs
Learn in Los Angeles. Practical instruction. Newest equipment. Master training courses. 10,000 graduates. Earn room and board while learning. Coach in R. F. Felt all the way to I. A. Send coupon for Catalog.

NATIONAL SCHOOLS - LOS ANGELES
Dept. SWC-12, 4000 S. Figueroa St.

NAME.....AGE.....
ADDRESS.....
CITY.....STATE.....

T. R. McELROY
WORLD'S CHAMPION RADIO TELEGRAPHER
23 Bayside Street, Boston, Mass.
MAC KEY @ \$7.95 a real speed key.
MAC KEY DELUXE @ \$15.00 U.S.N. Spfn.
MAC CORD @ \$1.00 U.S.N. Spfn speed key cord.
MAC CASE @ \$3.95 U.S.N. Spfn speed key case.
MAC OSC @ \$3.95 ac/dc oscillator. Tone control if u hv Mac Key wrt me to xmy ipt & dsrb infn.
All my stuff emcy gad best pduts obl. 73 Mac.

QUICK WAY to make money in RADIO
Modern receivers are demanding men with modern training for service work. New training method and service equipment offer starts you earning almost at once. Up to \$3 an hour easy in a short time. Write today for FREE book of details.
Radio Training Association of America
Dept. 5, W.C.-612
4525 Ravenswood Ave., Chicago

LEARN RADIO New Classes Now Forming! Send for 40-page catalog, explains fully. 300 licensed graduates placed in past 4 1/2 years in broadcasting, shipping, police radio, aviation, etc. We teach all branches. Oldest, largest and best equipped school in New England. Equipped with Western Electric sound and broadcasting equipment and RCA marine transmitter. Course prepares for United States Government telegraph or telephone license. Write Dept. S-12 for catalog.
MASS. RADIO SCHOOL, 18 Baylston St., Boston

RADIO ENGINEERING
RCA Institutes offers an intensive course of high standard embracing all phases of Radio. Practical training with modern equipment at New York and Chicago schools. Also specialized courses and Home Study Courses under "No obligation" plan. Catalog Dept. SIV-36.
RCA INSTITUTES, Inc.
78 Varick St., New York. 1154 Merchandise Mart, Chicago
Recognized Standard in Radio Instruction Since 1909

FIND OUT
what the world's largest home study Radio school offers you... **SEE BACK COVER**

yet unknown, but in the station list compiled by the Dept. of Commerce, ZGB is listed as on 7.50 and 8.955 mc. However, we believe a much higher frequency must be used to contact KAX 'way up on 19.98 mc.

Kenya Colony

GAD, 19.48 mc., Rugby, was heard foning VQG, 19.63 mc., at 9:30 a.m. VQG is located at Nairobi, and operated by same company that owns VQ7LO. Reports should be addressed to P. O. Box 777, Nairobi, Kenya Colony.

Czecho-Slovakia

A report has reached us that the sked of OLR, 15.23 mc., located at Podebrady, is now from 2:25-4:30 p.m., with English used at 4:15 p.m.

OLR has been heard by many listeners, and all comment on its tremendous signal strength, which makes its programs most enjoyable, being heard so well.

New Zealand

ZLT4, Wellington, 11.05 mc., is being heard often early a.m.'s, fones GBP, Rugby, 10.77 mc., thru VLZ, Sdney, 9.76 mc. ZLT4 is usually on the air from 1-4 a.m. The ZLT4 station now refuses to verify, evidently following suit of their contact station, VLZ, Sydney. A tough break for those who haven't yet verified New Zealand.

The liner "Normandie," 13.18 mc., was heard with a FB signal calling Paris at 4 p.m.

KKP, 16.03 mc. at Kahuku, Hawaii, fones KWV, Dixon, California, 15.355 mc., almost daily around 5:50-7 p.m. KKZ, Bolinas, Cal., 13.69 mc., was heard signing off one evening at 10 p.m., after relaying a broadcast.

LSL, Buenos Aires, 15.81 mc. was heard at 6 p.m. sending a musical program with a good signal.

DAF, the German fone at Nordeich, was heard foning at 5:20 a.m., on 17.26 mc. A veri from Germany of six of their commercial fones says they have no station known as DAN in operation.

DGH, 10.44 mc. at Nauen, Germany heard phoning at 4 p.m.

JVH 14.6 mc., Tokyo, Japan, is heard with a good "sig" on their midnite transmission, and often start before midnite. JVH is on the air daily 12-1 a.m. daily.

Siberia

ROU, 14.79 mc. at Omsk, Siberia, may be heard foning around 5:30-7 a.m. Fair signal on ROU.

RVU, Vladivostok, on 17.115 mc. was heard at 8 a.m. one day, but we could not locate the other end of the contact. A typical Asiatic signal, "fluttery," hard to "read." This is real DX, as Vladivostok is on the Pacific Coast, just off Japan.

Eddie Schmeichel, our Dxing friend from Chicago, reports hearing RVU and RTZ Irkutak near 17.11 mc. at 6:50 a.m. and RWJ foning Moscow at 1:15 a.m. Greetings, brother "nightowl"—don't you sleep either? Hi!

LZA, 14.97 mc., Sofia, Bulgaria, is heard often in the a.m.'s, tho not with a very strong signal. Heard well at 1:30 p.m. also.

KAZ, 9.99 mc., Manila, heard one a.m. at 5:30, calling some station, and the Shanghai station on 9.285 mc. also heard calling at same time. A woman was heard on Shanghai, seemingly calling Manila, but KAZ did not reply.

JVF, 15.62 mc., Tokyo, heard foning in "inverted" speech at 6 a.m. JVE phoned once at 3 a.m.

India

VWY2, 17.545 mc., located at Poona, India, was heard again, lately, at 8 a.m., their regular time of operation, using in-

Please mention SHORT WAVE CRAFT when writing advertisers

RADIO INSTRUCTION

YOU CAN'T KEEP PACE



With "MODEL T" TRAINING

A car ten years old is not more out-of-date today than are many radio servicemen. Radio service is becoming not only more technical, but also more highly competitive. The man who hopes to get ahead must have adequate MODERN training . . . NOW!

Here's the "Key to Successful Servicing"

ADVANCED HOME STUDY TRAINING IN RADIO SERVICE & PUBLIC ADDRESS

This course for professional radiomen has been prepared from years of actual work in the service field. We know what you men need and how to teach it. Insure your radio future by training now. Start any time—take up to 3 years to complete. Terms as low as \$5 monthly.



Free!

Write today for FREE illustrated booklet: "The Key to Successful Servicing." Get all the facts now!

RADIO SERVICE INSTITUTE

Subsidiary of CREI
DEPT. SW-12, 3308 14TH ST., N.W., WASHINGTON, D.C.

YOUR CODE—IS IT FAST? COMPLETE?

Radio amateur Code exams now require 30% more speed. INSTRUCTOGRAPH is the fastest, most practical method for beginners to learn code, and experts to develop speed. When you own your own INSTRUCTOGRAPH CODE TEACHER you can practice any time, at any speed desired. Comes in two models—Senior or Junior Economy, with complete book of instructions. You buy or rent, at low cost. Send postcard for complete details now to—



INSTRUCTOGRAPH COMPANY
Dept. SW-12
912 Lakeside Place
Chicago, Ill.
Canadian Representative
Radio College of
Canada, Ltd.
863 Bay St., Toronto

RADIO ENGINEERING

broadcasting, aviation and police radio, servicing, marine radio telegraphy and telephony, Morse telegraphy and railway accounting taught thoroughly. Engineering course of nine months' duration equivalent to three years of college Latin work. All expenses low. Catalog free. School established 1871.

Dodge's Institute, Turner St., Valparaiso, Ind.

A NEW BOOK
FUNDAMENTALS OF RADIO
Second Edition, 426 pages 6"x8", 430 figures. By R. R. Ramsey, Prof. of Physics, Ind. Univ. Revised, enlarged, repaged, reprinted. New cover. Radio theory and practice brought up to date. New subjects, problems and questions on each chapter. **EXPERIMENTAL RADIO**—(255 pages, 168 figures, 128 experiments.) The experimenter's manual.
Price, \$2.75.
Fundamentals, \$3.50 postpaid.
RAMSEY PUBLISHING CO.
Bloomington Indiana

RADIO COURSES
RADIO OPERATING: Prepare for Gov't License Exam. ● RADIO SERVICING: Including Short Wave ● AMATEUR CODE ● New Course in ELECTRONICS: Day and Evening Classes. Booklet Upon Request.
New York YMCA Schools
6 W. 64th Street, New York City

verted speech. This station was heard last fall daily at 8 a.m., in contact with GAU, 18.62 mc. Rugby. Signal strength varies from R7-R9, a most powerful Asiatic phone.

The Iceland station TFJ, on 12.24 mc., located at Reykjavik, is well heard on Sundays from 1:40 to 2:30 p.m., with first half of the program in English.

Tahiti

FO8AA, 7100 kc., located at Papeete, Tahiti, and called "Radio Oceanic," is reported to be putting an excellent signal into California, by our faithful reporter, Ashley Walcott. Ashley says that the signal is very strong but the code ruins the programs. Here's a real DX catch, and a challenge to all DXers who try for the rare 'uns! Sked is Tues. & Fri. from 11 p.m. to just after midnight.

Now to the reports of the South Americans and other stations, heard by our expert reporters. Only the more important data will be included, due to space limitations.

Here's a review of DX by Mr. R. B. Oxreider, whose QRA is State College, Penn.

A station, EDX, in Las Palmas, Canary Islands, has been heard on about 10.47 mc. about 9:30 p.m. Plays recordings, and begins news bulletins. Gives call as E for Espana, etc.

YNLF's latest move has been to 9.66 mc. COCX at Havana is a new station being heard. Jumps around as if he enjoys doing it, one nite announcing that he was on 11.65 mc. and was actually being received on 12.165 mc! COCX has been heard very close to 9.75 mc. lately.

TI4NRH is back on the air, with OM Cespedes Marin promising handsome new cards to all who report his station. Frequency used lately is 9.685 mc., or thereabouts.

HH3W heard lately on 9.63 mc. HJ1ABE now on 9.50 mc. HJ2ABC is being heard on about 9.59 mc., this being their latest move.

VP3MR has moved from the 40 meter "ham" band, due to pressure applied by amateur organizations, and can be found on 5.998 mc.

TIEP has been heard lately on 6.673 mc. HH3NW, the new Port au Prince station, at Haiti, is owned by HH3W, and heard on 6.35 mc.

XEWI has moved from 5.98 mc. to 11.90 mc.

HJ4ABD, Medellin, has moved from 5.77 mc. to 5.93 mc., but never stays put; seemingly.

Mr. Oxreider also reports a new Colombian on 9.53 mc., calling itself "La Vos de Armenia." Also a new Venezuelan on 6.35 mc.

HIX announced their new frequency as 6.34 mc.

A station believed to be EHZ, at Tenerife, Canary Islands, 10.37 mc., was heard every evening from 6 to 8 p.m. with a number of languages being used, among them English.

Thanks a million, Mr. Oxreider, and please come in often, OM, you certainly know ur S.A.'s!

Charles Miller of Covington, Kentucky, reports HC2JSB being heard on 9.51 mc. now, from about 4 to 11 p.m.

Last Minute Flash!

Our friend, Charles A. Morrison, I.D.A. President, has kindly agreed to send a free issue of the IDA Monthly "DX" Mag., which has both S.W. and BCB "DX tips", to all interested DXers who care to write for it.

For DXers in New York City, the IDA Beta Chapter, which meets at the home of Ed. Goss, IDA State Mgr., located at 812 Prospect Place, Brooklyn, N.Y., and all DXers will find these monthly meetings of interest. For information write to Mr. Goss.

Learn RADIO from REAL RADIO ENGINEERS!



Kendall Clough
Chief Engineer,
Clough-Brenke Co.
E. E. Gramer
Chief Engineer,
Standard Transformer Co.
Karl E. Hassel
Chief Engineer,
Zenith Radio Corp.
F. M. Schnell
Radio Engineer,
Crown Radio
Dr. C. M. Blackburn
Production Dept.,
R. R. Malby & Co.

Train Now at Home for Good Pay Spare-Time and Full-Time Jobs that Pay Up to

\$75 a Week

If you're dissatisfied with small pay—and an uncertain future—here's an opportunity that's too good to miss. Get my big brand new FREE book, "RADIO'S FUTURE AND YOUR OPPORTUNITY." This book tells how you can learn at home under the supervision of factory engineers, to make more money almost at once in Radio—how to make Radio your life's work, or use it to perk up \$7 to \$20 a week extra in your spare time.

MORE OPPORTUNITIES THAN EVER BEFORE

Radio is still forging ahead, 1936 beats all other years. Over 5 million new sets sold. Over 30 million dollars paid for service alone this year. Where only a few hundred men were employed a short time ago, thousands are employed today. And where a hundred jobs paid up to \$75 a week—there are thousands of such jobs today—many paying even more. New full time jobs and spare time jobs are being created all the time. Get my book and see how easy you can get started.

"SHOP TRAINING" FOR THE HOME

R-T-I Training is different. It comes to you right from the heart of the Radio Industry—right out of the factories where Radio sets and other vacuum-tube devices are made. It was planned and prepared and is supervised by big radio engineers IN these factories—by men appointed for the purpose. R-T-I will train you as the Radio Industry wants you trained.

TELEVISION, PHOTO ELECTRIC CELLS, PUBLIC ADDRESS SYSTEMS INCLUDED

Radio service work is plentiful but it's only the starting point in R-T-I Training. From there you'll go through the whole field of Radio and Electronics. You will learn about every new development, including Television so you'll be ready when Television breaks.

MAKES \$600 IN ONE MONTH

Herbert B. Thonson, Gorman, Texas, started making money with 12 lessons. Finished. He says, "Because of my R-T-I Training I made \$450 in September and over \$600 in October 1935. It pays to be R-T-I Trained."

BIG MONEY IN AUTO AND POLICE RADIO WORK

W. H. Carr, 402 N. 10th St., Kansas City, Kans. R-T-I student has charge of 35 radio equipped Police and Fire Department cars. He gets \$200.00 a month and free auto, gas, oil, etc. He says, "If I had not taken your course I would not be able to hold this job."

4 WORKING OUTFITS FURNISHED

Start almost at once doing part time radio work. I furnish 4 outfits of apparatus that you build into test equipment with which you can do actual jobs and earn extra money. My Training pays its own way and you get your money back if not satisfied. Age or lack of experience is no handicap.

FREE BOOK

Find out why R-T-I Trained men get "Quick Results" and "Big Results." Send for "Radio's Future and Your Opportunity" today. It tells about Radio's amazing opportunities. It describes my approved training—what R-T-I students are doing and making. It gives the names of 50 firms who endorse and recommend R-T-I. It's FREE!



RAY D. SMITH,
President
RADIO AND TELEVISION INSTITUTE
Dept. 219
2150 Lawrence Ave.
Chicago

MAIL COUPON FOR FREE BOOK

RAY D. SMITH, President
Radio and Television Institute (R-T-I)
2150 Lawrence Ave., Dept. 219, Chicago, Ill.

Without obligating me, send me FREE Book about spare-time and full-time Radio opportunities and how I can train for them at home.

Name

Address

City State

Free!

THIS USEFUL AND ORNAMENTAL WORLD-GLOBE LAMP

NEVER in the six years that SHORT WAVE CRAFT has been published, have we found anything that is as useful and ornamental as the WORLD-GLOBE LAMP we now offer free to our readers.

This useful, beautiful WORLD-GLOBE LAMP measures 17 1/2" high. It has an attractive colored shade, with nautical and map designs, is 8" in height and 16" in diameter. It is made of fine quality parchment, highly glazed, to assure long life. A slightly damp cloth quickly removes dust from the shade. The 6 1/4" globe, printed in many colors, has a full meridian, and rotates. Hundreds of names—countries, cities, rivers, oceans and others are clearly printed on the globe.

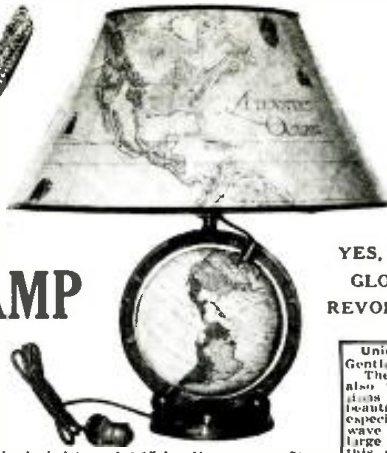

WHAT THEY SAY ABOUT THE WORLD-GLOBE LAMP!

All Admired It
Gentlemen:
I am perfectly satisfied with your GLOBE-LAMP. It is just what you have said about it in every way. All my family and friends have admired it. It arrived in perfect condition. Many thanks and the best of good luck to you and your SHORT WAVE CRAFT.
(Signed)
William Owens,
30 North Fifth Street,
Bangor, Penna.

Wouldn't Take \$15.00 For It
Gentlemen:
I received the Globe-Lamp and I am very much pleased with it. I think it is handsome and think a good deal of it. I wouldn't take \$15.00 for it. The lamp sets on top of the radio and is handy to glance at when I hear the foreign stations.
Warren G. Ryder,
Barnstable Radio Shop,
Barnstable, Mass.
P.S.: Many thanks for the lamp! WGR

YES, THE GLOBE REVOLVES!

Unique, Beautiful and Useful
Gentlemen:
The Globe-Lamp arrived today, also the magazine. Congratulations on a premium so unique, beautiful and, above all, useful, especially to DXers on the short wave bands. I already have a large globe, but I expect to use this small one much more frequently and with equal satisfaction. It goes fine with the new Hamnerlund "Super Pro."
T. H. Warnock,
99 Elm Street,
Meriden, Connecticut.

Very Well Pleased
Gentlemen:
I am very well pleased with my Globe-Lamp. It presents a handsome and novel appearance and is most appropriate when located near an all-wave radio set. When lighted at night, it sheds a warm, soft glow, and the parchment shade shows up most attractively. Unquestionably, the combination of the lamp and SHORT WAVE CRAFT for \$2.50 is a real bargain.
William E. Skaar, Jr.,
67 Exchange Street,
Rochester, New York.

MAIL COUPON TODAY!

SHORT WAVE CRAFT 99 Hudson Street, New York, N. Y. SWC-1236

Gentlemen: Enclosed you will find my remittance of \$2.50 (plus cents shipping charges) for which enter my subscription for SHORT WAVE CRAFT for one year (12 issues). This amount entitles me to a WORLD-GLOBE LAMP free. See chart next to coupon for shipping charges on WORLD-GLOBE LAMP.

() Enclosed find my remittance of \$2.50. Please send me the WORLD-GLOBE LAMP by express collect.

Name

Address

City State

Send remittance in form of check or money order—register letter if it contains cash, stamps, or currency.

Another feature on this WORLD-GLOBE LAMP is the movable hour scale found at the north pole. This permits determining the correct time in any part of the world.

The metal parts are finished in antique bronze. A piece of heavy green felt is glued under the base, therefore it may be placed anywhere, without fear of marring table, desk, etc.

The weight of the WORLD-GLOBE LAMP is nearly three pounds. When packed for shipping, six pounds.

Here is the way to get this beautiful prize. Fill in the coupon in the left hand corner—cut it out and mail it to us together with your remittance of \$2.50. You will receive a full year's subscription (12 months) to SHORT WAVE CRAFT—the greatest short-wave magazine in the world today. In addition, we will send you absolutely FREE one of these handsome WORLD-GLOBE LAMPS. Old subscribers may renew their subscription now for another year following expiration of their present one and still receive this WORLD-GLOBE LAMP.

Only a limited number of WORLD-GLOBE LAMPS are available. Take advantage of this offer without delay in order to insure receiving your free gift. RUSH THE COUPON TODAY.

How to Order Your WORLD-GLOBE LAMP

Simply fill in the coupon at the left and mail together with check or money order. Register letter if cash or coin is sent. To cover shipping charges on WORLD-GLOBE LAMP, add to your remittance the amount indicated. If you are located: East of the Mississippi add 35 cents; Between the Mississippi and the West Coast add 70c; Foreign Countries add \$1.30. Any excess remittance will be refunded.

SHORT WAVE CRAFT, 99 Hudson Street, New York, N. Y.

A New Variety of WORLD GLOBES

Here is a new variety of WORLD GLOBES which are indispensable to short-wave fans. Each globe contains a listing of several thousand cities in nations all over the world—and, such important features as: Admiral Byrd's trip to Little America; Lindbergh's flight to Paris; principal short-wave stations and call letters; steamship routes, etc. The globes have a graduated "Meridian" scale, also the movable hour scale at north pole which permits determining the hour in any part of the world.

The colors on the WORLD GLOBES are beautiful pastel shades, and harmonize with all surroundings. The globes are ideal for home, office, studio, den, etc. The map surfaces of all models are protected by a high, glazed water- and scratch-proof finish which can be washed by using a damp cloth. The finish will not fade or crack or become yellow with age.



World Globe No. P-212
This 12" standard globe lists principal international short-wave stations and call letters. 67 prominent stations are printed on this map. They are shown in red and easily distinguishable. Important data, as steamship routes, ocean currents, mountain peaks, railroads, Lindbergh's flight and other useful information will be found on this globe. A 32-page booklet, illustrated, entitled, "The Story of the Globe" is included with this world globe. Height—16 1/2". Shipping weight—6 1/2 lbs. PRICE \$2.95



World Globe No. P-512
Here is a Floor Stand World Globe that is truly a remarkable value for its low price. It has 12" standard globe mounted on a hard-wood stand of Duncan Phyfe design. The stand is richly finished in walnut. The globe is a regular heavy, graduated die cast meridian which is free-moving and completely reversible. Clearly printed on the globe are over 5,000 name places ocean currents, steamship routes, railroads, mountain peaks, Lindbergh's flight, Columbus voyage, etc. Principal short-wave stations are clearly printed in red. A 32-page booklet, well illustrated, entitled, "The Story of the Globe" is included free with this world globe. Height—34 1/2". Shipping weight—9 lbs., 10 ozs. PRICE \$4.45



World Globe Atlas No. R-12
This globe-atlas combination is excellent for home or office. The 12" library ball, with its brass-plated meridian, fits snugly into the finely constructed solid walnut stand. Provision is made below for the 383-page atlas which accompanies each globe at no extra charge. 67 short-wave stations are listed. Height—16 1/2". Shipping weight 12 lbs. PRICE \$6.85

All globes are protected and carefully packed in original, corrugated cartons, assuring safe delivery. ORDER by number. Send check or money order, plus sufficient postage for delivery by parcel post. Globes are shipped from our Chicago warehouse. Register letter if it contains cash, currency or stamps. Specify if shipment is to be sent express collect. ORDERS FILLED PROMPTLY.

NEW! ILLUMINATED GLOBE



Plug the electric cord attached to this globe into any socket, and the entire globe becomes illuminated from within. The light within the globe transforms the colored map into a radiant scene, and makes the printing on the globe easy to read. This translucent globe, recently developed, has the same sturdy, reinforced construction as other globes. The surface is protected by a heavy, glossy coat to assure longevity. The illuminated globe is easily dismantled to make bulb replacement. Each model is equipped with 11-foot electric cord, unbreakable plug, tubular light bulb and pull-chain socket. The revolving globe is 8" in diameter, mounted on an unbreakable die-cast base. Fittings are walnut brown. Lighted or unlighted this globe is a beautiful accessory for home, office, studio, etc. Height—16 1/2". Shipping weight—3 lbs. 5 ozs. PRICE \$2.80

SHORT WAVE CRAFT 99 HUDSON ST., NEW YORK, N. Y.

ORDER YOUR GLOBE TODAY!

SHORT WAVE CRAFT 99 Hudson St., New York, N. Y. SWC-12-36

Gentlemen: Enclosed you will find my remittance of \$ for which please ship me the following World Globe.

() Illuminated World Globe No. IG-8 @ \$2.80
() World Globe No. P-212 @ \$2.95
() World Globe No. P-512 @ \$4.45
() World Globe Atlas No. R-12 @ \$6.85

Name

Address

City State

Send remittance in check or money order—register letter if it contains cash, stamps or currency. GLOBES ARE SHIPPED FROM OUR WAREHOUSE IN CHICAGO. P.O.B. FROM THAT CITY.

Please mention SHORT WAVE CRAFT when writing advertisers

BARGAINS

First grade tubes—Licensed by R.C.A.—All merchandise guaranteed—All prices F.O.B. Newark, N.J. Orders for less than \$2.00 not accepted, 20% required on all orders.

Your Cost 19c	Your Cost 29c	Your Cost 29c	Your Cost 49c	Your Cost 49c
27	24A	43	1V	99STD
45	35-51	46	22	WD11
01A	36	49	32	WD12
12A	38	55	34	83V
26	39	75	53	6F7
30	41	77	59	PZH
31	44	78	79	182B
37	47	85	84	183
40	57	89	1A6	484
56	58	99V	1C6	485
71A	82	99X	2A3	686
78	83	2A3	2A7	10
80	523	2A6	2B7	81
00A	6D6	6C6	6A4 (LA)	12A7
		19	12Z3	6A6
		20	2525	6A7
		33	42	6B7
				624 (84)
				586
				6B5
				216B

- 6E5 or 6G5 Magic Eye tube, ea. .49
- 866 Heavy Duty Rectifier tube .89
- B. H. Raytheon Type Rectifier tube .89
- Photo Electric Cell (Potassium type) 1.25
- Photo Electric Cell (Caesium type) 2.95
- Supersensitive Relays for photo cells 2.95
- Fresh Friction type, 2 oz. .05
- Supersensitive Galena Crystal .10
- Genuine Bakelite panels 7" x 12" .69
- Cadmium Plated Chassis 5" x 9" .15
- 4-5-6-Prong Wafer sockets, ea. .04
- 4-5-6-Prong Isolantite sockets, ea. .24
- 4-5-6-Prong Eby Panel Mounting sockets, ea. .12
- AC-DC Line Cord Resistors, any size .29
- Coils, set of 4, 15 to 200 meters, 4 prongs .39
- 4-5-6 Prong plug-in coil forms, ea. .07
- Metal End Resistors, any ohms .05
- Test Prods .22
- Aluminum panels 7" x 12" .48
- Double Button Microphones 200 ohms per button 2.95
- Best Grade Push Back wire, 25 ft. .12
- 1 lb. of Hookup wire .10
- Spaghetti tubing 30" lengths .03
- Microphone springs, best grade, 8 for Rola F4 Dynamic Speakers 5"-3000 ohms 2.15
- Full Wave Auto Vibrators for all sets 1.69
- R.C.A. 8" Magnetic Speakers 1.95
- Magnavox 5" Auto Speakers 5.5 ohms Dynamic 1.89
- Magnavox 6" Dynamic Speakers 1800 ohms 2.20
- 5" Magnetic Speakers .89
- 5" Dynamic Speakers 3M ohms 1.69
- 2 Gang 140 mmf. Midget Condenser 1.05
- 2 Gang 150 mmf. Midget Condenser 1.05
- 1 Gang 140 mmf. Midget Condenser .55
- 1 Gang 150 mmf. Midget Condenser .55
- Indoor Ribbon Aerial .26
- Insulated Tips and Jacks, ea. .05
- Desk Mike stands, chromium plated .19
- Pie Wound 2 1/2 M.H. Short Wave, R.F. choke Tube shields, for 56-57, etc., type tubes .06
- 1 mf. electrolytic condenser, 500 volts .22
- 2 mf. paper condensers, 450 volts .26
- 10 mf. electrolytic condenser, 35 volts .23
- Band spread variable condensers .19
- Midget Antenna Trimmer 3 to 30 mmf. .22
- Binding post with hardware, ea. .05
- Back numbers of Short Wave Craft Magazines 3 for .28
- 100 mmf. Midget Variable condensers .55
- Octal base wafer sockets for metal tube .06
- 3" Airplane Dial 2 pilot light sockets included .55
- 5" Airplane Dial 2 pilot light sockets included 1.29
- 3" Bakelite Vernier Dial Kurtz Kasch .45
- 4" Bakelite Vernier Dial Kurtz Kasch .59
- Genuine R.C.A. tube type 6H6 .49
- Genuine R.C.A. type 6A8 tube .59
- Genuine R.C.A. tube type 6K7 .59
- Phone plugs .19
- Potentiometers, 10M, 50M, 75M .39
- Trimmer condensers Isolantite base 35 mmf. .26
- Midget Tuning Condensers 35 mmf. .69
- .001 mf. Mica condenser .07
- R.C.A. single button hand mike .19
- Flashlight cells (fresh) .05
- Shield cans for coils .05
- Insulated Banana Tips and Jacks, ea. .06
- Carbon Granules Finest grade .33
- Gold Spotted Mike Diaphragms .89
- Crystal Sets (very selective) I.C.A. .51
- Dual 8 mf. 500 volts Electrolytic Condenser .59
- Double Pole, Double Throw Toggle Switch .37
- 3 ft. Rosin core Solder .09
- Insulex Coil Forms .19
- Home Broadcasters mikes .10
- Jewelled Pilot Light Brackets .14

If any parts you require are not listed, write to us for quotations and compare prices with others.
NO CATALOGUE—BUT LOWEST PRICES
REXTRON 37 Lock Street NEWARK, N.J.

SHORT WAVE SCOUTS

(Continued from page 467)

- tady, New York.
- W2XAF—9,530—General Electric Co., Schenectady, New York.
- W3XAL—17,780—National Broadcasting Co., Bound Brook, New Jersey.
- W3XAL—6,100—National Broadcasting Co., Bound Brook, New Jersey.
- W3XAU—9,590—Philadelphia, Pennsylvania.
- W3XAU—6,060—Philadelphia, Pennsylvania.
- W3XL—6,400—National Broadcasting Co., Bound Brook, New Jersey.
- W4XB—6,040—"Isle of Dreams" Broadcasting Corp., Miami, Florida.
- W8XAL—6,060—Crosley Radio Corp., Cincinnati, Ohio.
- W9XAA—11,830—"Voice of Labor," Chicago, Illinois.
- W9XAZ—31,600—Milwaukee Journal Co., Milwaukee, Wisconsin.
- W9XF—6,100—National Broadcasting Company, Chicago, Illinois.

FOREIGN SHORT WAVE STATIONS

- CANADA**
- CJRO—6,150—James Richardson & Sons, Ltd., Winnipeg, Manitoba, Canada.
- CJRX—11,720—James Richardson & Sons, Ltd., Winnipeg, Manitoba, Canada.
- VE9CA—6,030—"The Voice of the Prairies, Limited" Calgary, Alberta, Canada.
- VEDND—6,005—Canadian Radio Broadcasting Commission, Montreal, Quebec, Canada.

CENTRAL AMERICA

- HONDURAS**
- HRD—6,235—"La Voz De Atlantida" La Ceiba, Honduras, C.A.

GUATEMALA

- TGW—9,450—Sun. Radiodifusora Nacional, Guatemala City, Guatemala, C.A.
- TG2X—5,940—"De La Policia Nacional De Guatemala" City, Guatemala, C.A.

PANAMA

- HP5B—6,030—"Radio Club Miramar," Panama City, Panama, C.A.
- HP5J—9,590—"La Voz De Panama," Panama City, Panama, C.A.

COSTA RICA

- TIEP—6,710—"La Voz Del Tropico," San Jose, Costa Rica, C.A.
- TIPG—6,410—"La Voz De La Victor," San Jose, Costa Rica, C.A.
- TIRCC—6,550—"Radioemisora Catolica Costarricense," San Jose, Costa Rica, C.A.

MEXICO

- XEBT—6,000—Mexico City, Mexico, C.A.
- XECR—7,380—Foreign Office, Mexico City, Mexico, C.A.
- XEFT—9,505—"La Voz De Vera Cruz" Vera Cruz, Mexico, C.A.
- XEFT—6,120—Same as 9,505 kc. "One card for both."
- XEME—8,190—"La Voz De Yucatan," Merida, Yucatan, Mexico, C.A.
- XEUW—6,020—"El Eco De Sotavento Desde Vera Cruz" Vera Cruz, Mexico, C.A.
- XEVI—5,975—Mexico City, Mexico, C.A.
- XEXA—6,171—Dept. of Education, Mexico City, Mexico, C.A.

WEST INDIES

- HAITI**
- HH2S—5,910—"Societe De Radiodifusion," Port Au Prince, Haiti, W.I.
- HH3W—9,595—Port Au Prince, Haiti, W.I.

CUBA

- COCD—6,130—"La Voz Del Aire," Havana, Cuba, W.I.
- COCH—9,428—General Electric Co., Havana, Cuba, W.I.
- COCO—6,010—Havana, Cuba, W.I.
- COKG—6,150—Santiago, Cuba, W.I.
- CO9C—6,150—Verified on same card as "COKG." Call used irregularly for "test" purposes. Santiago, Cuba, W.I.
- CO9JQ—8,665—Camaguey, Cuba, W.I.

DOMINICAN REPUBLIC

- HIT—6,630—"La Voz De La RCA Victor," Ciudad Trujillo, D.R. W.I.
- HIX—5,980—"Radiodifusora HIX," Santo Domingo, Dom. Rep. W.I.
- H11J—5,865—San Pedro De Macoris, Dom. Rep. W.I.
- H11S—6,420—"La Voz De La Hispaniola," Puerto Plata, Dom. Rep. W.I.
- H13C—6,105—"La Voz De La Feria," La Romana, Dom. Rep. W.I.
- H13U—6,383—"La Voz Del Comercio," Santiago, Dom. Rep. W.I.
- H15N—6,150—"La Voz Del Almacen Dominicano," Santiago, Dom. Rep. W.I.
- H15X—14,090—Boca Chica, Dom. Rep. W.I.
- H18A—6,600—"Radiodifusora H18A," Santo Domingo, Dom. Rep. W.I.

SOUTH AMERICA

- HCK—5,885—"Radiodifusora Del Estado," Quito, Ecuador, S.A.
- HC2RL—6,635—Guayaquil, Ecuador, S.A.
- HJ1ABE—6,115—"La Voz De Los Laboratorios Fuentes," Cartagena, Colombia, S.A.
- HJ1ABG—6,042.5—"Emisora Atlantico," Barranquilla, Colombia, S.A.
- HJ1ABP—9,600—"Radiodifusora Cartagena," Cartagena, Colombia, S.A.

(Continued on page 515)

BRUSH Hand Microphone



For describing athletic events, parades, crowds, etc., from press boxes, balconies, the tops of sound cars, etc., and for commercial interstation, police and amateur transmission work. Priced low. Fits the hand perfectly. Wide frequency response and typical Brush sound cell operation. No button current or polarizing voltage and no input transformer is required. Size only 3 1/4 inches x 1 1/4 x 1/2 inches. Weight 3 oz. Output level minus 66 D. B. Shipped complete with 15 feet of cable. Can be furnished on special order with locking type plug and socket for stand connection. Details—Data Sheet No. 8. Free. Send for one.

BRUSH Headphones



—meet every headphone requirement. Response 60 to 10,000 cycles. No magnets to cause diaphragm chatter. Specially designed cases minimize breakage. Light in weight—Only 6 oz. complete with headband and cords. A quality product at a low price. Details—Data Sheet No. 10. Free. Send for one.

The BRUSH DEVELOPMENT COMPANY

1887 Booth St. CHICAGO, ILL. U.S.A. CLEVELAND, O.

WORLD WIDE ALL WAVE RADIO

ONE TUBE ONLY SET \$1.25

Here's just the thing you've always wanted! A real, powerful Radio receiver all your own! A Short and Long Wave Set that can actually bring in many foreign stations from all parts of the World, police calls, air, phone, amateur, etc., as well as your local stations. ACE Radios give GUARANTEED RESULTS! Thousands now in use. Amazing performance!

Now, the world famous ACE Construction Kits are priced so low that anyone can afford one! For only \$1.25, we send you, postpaid, every part needed to build a powerful one tube receiver with heavy, attractive metal chassis-panel. Not a feeble crystal set! Works on two inexpensive dry batteries. Later, you can change your set into the Ten Tube Battery or All-Electric set at special low cost! You get a valuable radio education by wiring it yourself from our clear diagrams. It's easy for even a child! Just a few simple connections. Wavelength range 15 to 600 meters.

FOR MORE POWER AND VOLUME \$2.00 BUY THE TWO TUBE KIT

Unwired, less tubes, batteries, phone.

ALL ELECTRIC TWO TUBE RECEIVER \$3.00

Unwired, less tubes, batteries, phone.

Ya batteries needed. Just plug into any 105 to 125 volt AC or DC house line. Complete Kit

Tubes—75c each. Jubilee headphones—\$1.15. Any kit laboratory wired and tested—75c extra. REMEMBER!—WE pay the Postage! Save you 15c to 50c or more.

ORDER NOW! NOT A TOY OR AN ATTACHMENT!! ACE RADIO LABORATORIES

70 Barclay St., Dept. C-12 New York City

OHMITE RHEOSTAT



"For maximum output and longest life," say the manufacturers of transmitting tubes, "the filament power supply must be accurately controlled." OHMITE patented construction gives really close control. Ask your dealer or write for full information to OHMITE MANUFACTURING CO., 4839 Flournoy St., Chicago, Ill.

Print Your Own

Carls. Stationery. Circulars. Advertising, etc. Save money. Print for others. Big profit. Junior press, \$5.99. Job press \$11 up. Power \$149. Easy rules sent. Write for free catalog with all details. THE KELSEY CO., Y-28, Meriden, Conn.

NEW **10** CENTS
 "how-to-make-it"
PUBLICATIONS
 for
Experimenters



WE list below a large number of radio, short-wave, and mechanical "how-to-make-it" designs. Each is a special publication originated by masters in their respective fields. For the first time, at the low price of TEN CENTS, you are now enabled to buy a complete design with photographic reproductions, complete mechanical layout, and full description to make it possible for anyone to build the project in question. The name of "Radio Publications" has become a household word

because this company has for many years specialized in radio and other literature of special interest to the experimenter. PLEASE ORDER EACH PROJECT BY ITS PUBLICATION NUMBER, and use the special coupon below. We accept money-orders, cash, checks or new U. S. stamps. (No foreign stamps or currency can be accepted.) If you send cash or stamps, be sure to register your letter to safeguard against loss. Money refunded if you are not satisfied. ANY TWELVE PUBLICATIONS FOR ONE DOLLAR.

Complete List of 10c Publications
SHORT-WAVE RECEIVER PUBLICATIONS

HOW TO MAKE THE "OSCILLODYNE" 1 TUBE WONDER SET. One of the most sensitive short-wave sets designed, employing a really new circuit for the first time. Battery operated. No. 101
HOW TO MAKE THE "19" TWINPLEX (ONE TUBE PERFORMS AS TWO) RECEIVER. One of the most sensitive 1-tube sets ever designed and very popular. No. 102
HOW TO MAKE THE WIZARD 1-TUBE 50-WATT TRANSMITTER. An amateur, crystal-controlled c.w. transmitter using the RK20 screen grid pentode. In tests, it compares with 250-watters. No. 103
HOW TO MAKE THE IMPROVED 3-TUBE DOERLE SET FOR BATTERY OPERATION. One of the finest of the Doerle series, by the famous short-wave inventor. No. 104
HOW TO MAKE THE "GO-GET-EM 2" RECEIVER FOR THE BEGINNER. This unusual 2-tube circuit gives 3-tube results. Battery operated. Excellent for beginners. No. 105
HOW TO MAKE THE 1-TUBE ALL-ELECTRIC OSCILLODYNE. This is the famous electrified short-wave receiver. Easy to build for little money. Operates on A.C. and D.C. No. 106

HOW TO MAKE THE 2 TO 5 METER TWO-TUBE LOUDSPEAKER SET. This receiver may be used with batteries or with an A.C. power pack. Packs a big wallop. No. 107
HOW TO MAKE THE 3-TUBE BATTERY SHORT-WAVE RECEIVER. This receiver was a prize winner in SHORT WAVE CRAFT. An unusual short-wave receiver, easy to build. No. 108
THE BRIEF-CASE SHORT-WAVE RECEIVER AND HOW TO BUILD IT. So small that the entire set, batteries, head set, aerial and everything goes into a briefcase. Stations from Europe are often received. By Hugo Gernsback and Clifford E. Denton. No. 109
HOW TO BUILD THE POCKET SHORT-WAVE RECEIVER. One of the smallest, pocket-size, battery receivers ever designed by Hugo Gernsback and Clifford E. Denton. A marvelous set that brings in European stations. No. 110
HOW TO BUILD THE CIGAR-BOX 1-TUBE "CATCH ALL" RECEIVER. An effective short-wave battery set which fits into a small cigar-box, insuring high portability yet great efficiency. No. 111
HOW TO BUILD THE "DUAL-WAVE" SHORT-WAVE BATTERY RECEIVER. With this set, you can hear both ends of radiophone talk, on one set of phones. In other words, you can listen to a ship at sea and the

land station communicating with it, simultaneously, by means of this double receiver. No. 112
HOW TO BUILD THE 1-TUBE "53" TWINPLEX RECEIVER. The twinplex, although it has only one tube, works as if it had two. Marvelous in efficiency. Uses either batteries or A.C. power pack for "B" supply. No. 113
HOW TO BUILD THE PORTABLE MINIDYNE SHORT-WAVE BATTERY SET. Uses no aerial, no ground. The total weight is 3 3/4 lbs and measures 5x5x6 inches. Self-contained batteries, tube, condensers, and loop. Highly sensitive circuit. No. 114
HOW TO BUILD THE HAM-BAND "PEE-WEE" 2-TUBE. A dandy receiver with high efficiency and band-spread tuning. Works a loudspeaker, yet the entire receiver is no larger than your hand. Works with either batteries or an A.C. power pack. No. 115
HOW TO BUILD THE DUO-AMPLIDYNE. The ideal 1-tube set for the beginner. One of the finest 1-tube sets; it really gives 2-tube performance. Made for battery operation. With only ten-foot antenna brings in the good European stations. No. 116
HOW TO BUILD THE "MONO-COIL 2". No more "plug in" coils. This set eliminates bothersome coils and is made to cover short-wave bands. Works with either batteries of A.C. power pack. No. 117

RADIO BROADCAST RECEIVER AND SPECIAL RADIO PUBLICATIONS

HOW TO MAKE THE A.C.-D.C. "CASH BOX" RECEIVER. One of the smallest practical all-wave receivers. Fits in a small metal cash box (1 1/4 x 5 1/4 x 2 1/2 ins. deep, inside dimensions of the box; 1 1/4 x 5 1/4 x 1 ins. inside dimensions of the cover). No. 118
HOW TO MAKE BEGINNER'S 2-TUBE ALL-WAVE SET. Using new metal tubes. Uses standard parts—good for all-around work. Broadcast as well as short waves. Works with batteries, A.C. power pack or A.C.-D.C. power pack. No. 119
HOW TO BUILD THE "RADIOLAMP" 4-TUBE TABLE RECEIVER. This set uses a lamp shade as a loudspeaker in a specially constructed receiver that works on A.C. or D.C. No. 120
HOW TO BUILD A SUPER-SENSITIVE ALL-WAVE CRYSTAL SET. Just the thing for beginners who wish to have an easy-to-operate crystal set on all-waves and which will separate all the stations. Can be made for less than \$2.00. Uses no tubes or batteries. No. 121
HOW TO BUILD THE 2-TUBE "PENTODE PORTABLE" BROADCAST SET—the lightest, smallest set

giving loudspeaker volume on batteries. Weighs less than 12 pounds. Built in a small, portable case. No. 122
HOW TO BUILD THE RADIO "TREASURE" FINDER. This is a really sensitive and practical "Treasure" finder. Simple to build and guaranteed to work. Uses 4 tubes. Can be built for less than \$15.00. No. 123
HOW TO BUILD THE GERNSBACK ONE-TUBE PEN-TODE LOUDSPEAKER SET. This is the best one-tube loudspeaker set ever constructed. It works on batteries, and is for broadcast reception. Extremely sensitive. No. 124
HOW TO BUILD THE WORLD'S SMALLEST ONE TUBE BATTERY RADIO. So small that it is actually built in a cigarette case. The wonder set of the last New York Radio show. No. 125
HOW TO BUILD A 6-TUBE BATTERY ALL-WAVE "FARM PORTABLE" SET. ranging from 12 to 2,100 meters. A real portable that bulls in the stations. No. 126
HOW TO MAKE AN A.C.-D.C. ONE-TUBE "DEAF AID." An excellent aid for the hard-of-hearing and deaf.

for theatres, churches, and the home. A god-send for all afflicted persons. Can be built for a few dollars. No. 127
HOW TO BUILD A PIANOTRON: For less than two dollars, plus a few junk parts which you have, you can now make a beautiful musical instrument. Operated by three radio tubes. It has an actual keyboard, and you can play tunes. Works on "A" and "B" batteries. A great novelty due to the unusual music which issues from the loudspeaker. No. 128
HOW TO BUILD THE ONE-DOLLAR RADIO. Impossible though it sounds, for one dollar you can build a radio set which includes a radio tube and a half of headphones and batteries. You make everything yourself, outside of the three last mentioned items, from wood and spare metal parts. No. 129
HOW TO MAKE A VARIABLE-TONE CODE PRACTICE SET. One of the finest code-practice sets of its type ever designed. Uses a single radio tube and gives sound exactly as you get it via radio. Works with batteries or with an A.C. power pack. No. 130

MECHANICAL PROJECTS PUBLICATIONS

HOW TO MAKE A SOUTH SEA OUTRIGGER CANOE. A craft that will furnish plenty of thrills. Equally safe and swift in smooth and rough water. Uses most and big for large sail. No. 131
HOW TO BUILD A PEE-WEE AUTOMOBILE. An ultra-small automobile that can be built for less than 10 dollars. Will carry two 17-year-old boys. Runs 35 miles per hour and 100 to 125 miles on one gallon of gas. No. 132
HOW TO BUILD A DUAL-CONTROL GLIDER. A safe perfectly-balanced glider of the open, semi-canilever, monoplane type. Wingspan, 42 feet; wing area, 220 square feet; weight, 290 lbs. empty; flying speed, 27 m.p.h.; landing speed, 22 m.p.h. Simple to build. No. 133
HOW TO BUILD A HOUSEBOAT ON PONTOONS. The house is erected on two pontoons coupled together. Will "hook" four persons comfortably. Uses outboard motor for propulsion. Has convenient galley, sink with running water, marine toilet and other home comforts. No. 134
HOW TO MAKE A BAND SAW FROM OLD AUTO PARTS. Made from old Ford and Chevrolet parts. Capable of performing delicate and satisfactory work. Uses 25-gauge 10 and 12-inch band saws. Assembly is easy for each part fills its allotted place perfectly. No. 135
HOW TO BUILD A REAL LATHE FOR \$5.00. Requires

a few hand tools, about \$5.00 worth of raw material and patience to build. The lathe is capable of drilling, milling, turning, boring and thread cutting. No. 136
HOW TO BUILD A SAIL CRAFTBOAT. A practical sailboat with provisions for outboard motor. Has smart, speedy lines and a comfortable sleeping cabin for two people. An excellent racing and fishing boat. No. 137
HOW TO BUILD A SIMPLE PORTABLE REFRIGERATOR. A real refrigerator. Does not use ice. The cooling unit operates from an alcohol flame oil burner or open fire. Easy and inexpensive to build. Excellent for boats, camps, homes, etc. No. 138
HOW TO BUILD A XYLOPHONE. An easily constructed instrument of wonderful tone quality. Made of slide of wood cut to definite size, depending upon the pitch desired. This instrument is easily converted into a marimbaphone. No. 139
HOW TO BUILD THE ROWMOBILE. An excellent muscle-building sport machine made from four bicycle wheels and a unique hand-driven propulsion system. Capable of doing 20 miles per hour. No. 140
HOW TO BUILD LARGE TESLA AND OUDIN COILS GIVING 18-INCH SPARKS. Interesting high-frequency apparatus with which many high-frequency and x-ray

experiments can be performed. Capable of producing 15,000 volts. No. 141
HOW TO MAKE AN ARC WELDER. A real arc welder capable of doing commercial jobs satisfactorily. Uses a heavy-duty transformer which operates from the 110-volt A.C. main. The output of the machine ranges from 15 to 100 amperes. No. 142
HOW TO USE AN A.C. ARC WELDER. Continuation publication to the one listed directly above. Very informative; especially to the garage man or mechanic who has had little or no experience with an arc welder. Contains many important diagrams and photographs of actual work done with an arc welder. No. 143
HOW TO MAKE YOUR OWN MICROSCOPE. A microscope which the home mechanic can easily build in his shop. The lenses are obtained from the finders of a camera. Although simple and easy to build, it is a thoroughly practical and efficient instrument. No. 144
HOW TO MAKE A WIMSHURST ELECTROSTATIC MACHINE. An easily constructed generator of static electricity capable of discharging a fat three-inch spark. Used in schools where electricity is taught. Can be built for less than \$2.00. No. 145
HOW TO MAKE A POWER DRILL PRESS FROM SCRAP PARTS. An excellent practical drill press that will make work easier for the mechanic. About \$2.00 worth of raw material and scrap iron are the only requirements. No. 146
HOW TO BUILD A GOOD LATHE FOR \$1.00. This practical lathe is adapted to high-speed turning of very small parts. Just the thing for ship model and toy making. No. 147
HOW TO MAKE AND EXPERIMENT WITH AN ELECTROPHOROUS. With this device numerous interesting experiments with static electricity can be performed. Many of these experiments are thoroughly explained and illustrated. No. 148

RADIO PUBLICATIONS, 101 Hudson Street, New York, N. Y. SWC-1236

I enclose \$..... for the publications listed by number, at right, at 10c a copy (ONE DOLLAR FOR ANY TWELVE PUBLICATIONS.) These publications are to be sent to me postpaid. I have placed a circle around each number which I want.

101	102	103	104	105	106
107	108	109	110	111	112
113	114	115	116	117	118
119	120	121	122	123	124
125	126	127	128	129	130
131	132	133	134	135	136
137	138	139	140	141	142
143	144	145	146	147	148

Name Address
 City State

Please mention SHORT WAVE CRAFT when writing advertisers

ONLY \$4⁹⁶
U. S. NAVY AIRPLANE-TYPE Microphone and Receiver

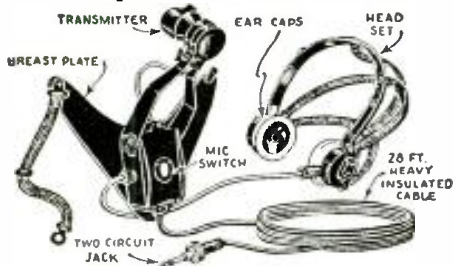

THIS Microphone and telephone headset outfit was built especially for the U. S. Navy Aviation Corps for Plane-to-Plane and Plane-to-Ground communication.

The Holtzer-Cabot Electric Company constructed the outfit to Government specifications and under rigid Navy Department supervision.

The outfit consists of a low-impedance carbon microphone (transmitter), securely fastened to a metal breastplate, and a set of heavy-duty, low impedance earphones. A specially constructed switch on the back of the breastplate controls the microphone circuit. The earphones are U.S.N. Utah type, attached to adjustable headband. Twenty-eight feet of very heavy weather and waterproof conductor cable, terminating in a special brass plug, is furnished with this complete outfit. Current of not more than 10 volts should be used. A storage battery is the most satisfactory current supply. Talk in a natural tone of voice, when using the outfit, with the lips close to the mouthpiece. Shouting and loud talking should be avoided.

We understand that the U. S. Government paid more than \$40.00 for each of these outfits. We have bought the whole lot at a low price and are offering them, as long as the supply lasts, at \$4.96 each, complete as shown in illustration. The shipping weight is 9 lbs.

Merchandise in original packages—
 Never used—Money-back Guarantee.

All Shipments will be forwarded by Express
 Collect if not sufficient postage included.

WELLWORTH TRADING CO.
 560 W. Washington Blvd., Dept. SW-1236, Chicago, Ill.

S-W Scouts

(Continued from page 513)

- HJ3ABD—6,050—"Colombia Broadcasting," Bogota, Colombia, S.A.
- HJ3ABH—6,012—"La Voz De La Victor," Bogota, Colombia, S.A.
- HJ4ABC—6,451—"Ecos Del Combeima" Ibazue, Colombia, S.A.
- HJ4ABP—6,030—"Emisora Philco" Medellin, Colombia, S.A.
- HJ5ABC—6,150—"La Voz De Colombia," Cali, Valle, Colombia, S.A.
- HJU—9,510—"La Voz Del Pacifico," Buenaventura, Colombia, S.A.
- LRU—15,290—"El Mundo," Buenos Aires, Argentina, S.A.
- LRX—9,580—"El Mundo," Buenos Aires, Argentina, S.A.
- OAX4D—5,780—"All American Cables," Lima, Peru, S.A.
- OAX4G—6,230—Lima, Peru, S.A.
- OAX4R—14,150—Lima, Peru, S.A.
- EL PRADO—6,625—Riobamba, Ecuador, S.A.
- PRF5—9,501—Rio De Janeiro, Brazil, S.A.
- PR8—6,040—"Avoz Do Norte," Radio Club of Pernambuco, Pernambuco, Brazil, S.A.
- YV2RC—5,800—"Broadcasting Caracas," Caracas, Venezuela, S.A.
- YV3RC—6,150—"Radiodifusora Venezuela," Caracas, Venezuela, S.A.
- YV6RV—6,520—"La Voz De Carabobo," Valencia, Venezuela, S.A.
- YV12RM—6,300—"La Voz De Aragua," Maracay, Venezuela, S.A.

EUROPE

- CT1AA—9,650—"Radio Colonial," Lisbon, Portugal.
- EAQ—9,860—Madrid, Spain.
- OER2—6,072—Vienna, Austria.
- SPW—13,635—Warsaw, Poland.
- HAS3—15,370—"Radiolabor," Budapest, Hungary.
- HAT4—9,125—"Radiolabor," Budapest, Hungary.
- ORG—19,200—Ruyselede, Belgium.
- ORK—10,330—Ruyselede, Belgium.
- PCJ—15,220—"Philips Radio," Eindhoven, Holland.

- PHI—11,730—Huizen, Holland.
- RIO—10,170—Bakou, U.S.S.R.
- RW50—12,000—"Radio Centre," Moscow, U.S.S.R.

- GAS—18,310—Rugby, England.
- GAU—18,620—Rugby, England.
- GBB—13,585—Rugby, England.
- GDS—6,905—Rugby, England.
- HB9B—14,236—"Radio Club Basel," Basel, Switzerland.
- HBL—9,595—"Radio Nations," Geneva, Switzerland.

- HBO—12,035—"Radio Nations," Geneva, S.
- HBP—7,797—"Radio Nations," Geneva, S.
- Rad. Colon.—15,245—Paris, France.
- Rad. Colon.—11,880—Paris, France.
- Rad. Colon.—11,715—Paris, France.
- TYA1—12,215—Paris, France.

- HVJ—15,121—Vatican City, Rome, Italy.
- HVJ—5,969—Vatican City, Rome, Italy.
- 2RO4—11,810—Rome, Italy.
- 2RO3—9,635—Rome, Italy.
- 2RO1—6,084—Rome, Italy.
- DGH—10,440—Nauen, Germany.

- DJA—9,560—Broadcasting House, Berlin, Germany.
- DJB—15,200—Brd. House, Berlin, Germany.
- DJC—6,020—Broadcasting House, Berlin, Germany.

- DJD—11,770—Brd. House, Berlin, Germany.
- DJE—17,760—Brd. House, Berlin, Germany.
- DJL—15,110—Brd. House, Berlin, Germany.
- DJM—6,079—Brd. House, Berlin, Germany.
- DJN—9,540—Brd. House, Berlin, Germany.
- DJO—11,795—Brd. House, Berlin, Germany.

- DJP—11,855—Brd. House, Berlin, Germany.
- DJQ—15,280—Brd. House, Berlin, Germany.
- DJR—15,340—Brd. House, Berlin, Germany.
- DJS—12,130—Reichspostzentramt, Zeesen, Germany.

- DZA—9,675—Zeese, Germany.
- DZB—10,042—Zeese, Germany.
- DZH—14,460—Zeese, Germany.
- DZG—15,360—Reichspostzentramt, Zeese, Germany.

ASIA

- JVM—10,740—Nazaki, Japan.
- JVN—10,660—Nazaki, Japan.
- JVP—7,510—Nazaki, Japan.
- VWY-2—17,510—Kirkee, India.

AFRICA

- CNR—12,830—Rabat, Morocco.
- OPL—20,040—Leopoldville, Belgian Congo.

AUSTRALIA

- VK3LR—9,580—Melbourne, Australia.
- VK2ME—9,590—Amalgamated Wireless Ltd., Sydney, Australia.
- VK3ME—9,510—Amalgamated Wireless Ltd., Melbourne, Australia.

EAST INDIES

- PLP—11,000—Bandoung, Java, E.I.
- (One card for both)
- PMN—10,260—Bandoung, Java, E.I.

ISLANDS

- EA8AB—7,211—"Radio Club Tenerife," Santa Cruz, Canary Islands.
- TFJ—12,235—"Icelandic State Broadcasting Service," Reykjavik, Iceland.
- VPI—13,075—"Amalgamated Wireless of Australia Ltd.," Suva, Fiji Islands.

EVERY RADIO MAN IS TALKING ABOUT THE BIG CONDENSER FIGHT

Tubular TOBE TUBIDON is a cinch to win, say some radiomen. It's a self-supporting condenser, easy to install, uses less space, and actually costs less!

But rectangular TOBE FLEXIDON has the one big feature, say others. It's "flexible" . . . if one section breaks down, due to overload, only that one section need be replaced. The units are completely separate.

Our opinion is . . . BOTH ARE GREAT CONDENSERS! We leave it to you experimenters, servicemen, dealers, etc. to decide WHICH is best. All good supply houses have them. Do you want a catalog, and full technical description of these double-jacketed condensers? Please write today to TOBE DEUTSCHMANN CORP., Dept. M-14, Canton, Massachusetts.



ELECTROLYTIC CONDENSERS
 Skillfully Manufactured at Canton, Mass.

TRADE-IN

We have been doing this for several years and made many friends through our fair dealings.

We handle every well known Amateur receiver and transmitter. We specialize in NATIONAL, HAMMARLUND and RME.

EASY MONTHLY TIME PAYMENT PLAN

All inquiries will be promptly and intelligently answered. Inquiries from foreign countries solicited.

SCHWARZ RADIO SERVICE
 15 Lawrence Ave., Dumont, N. J.



AMERICAN Microphone Co., Inc.

New D-3 Dynamic

High Fidelity

● Rugged ● Stable ● Dependable.
 An All-Purpose Microphone.

New catalogue available upon request.

1915 South Western Ave., Los Angeles, Calif.

Manufacturers of

VITREOUS TRANSMITTING GRID LEAKS
 VOLUME CONTROLS • POWER RHEOSTATS

Write for Complete Free Catalog

ELECTRAD, Inc.

175 Varick Street, New York

Professional Model Ultra Violet SUN LAMP

This is a large Chromium plated lamp using standard carbons, emitting rays of ultra violet and infra red. If sun tan is desired, specify **SUN TAN CARBONS**. Complete with screen and goggles. \$7.50. Descriptive circular sent FREE.

Gold Shield Products Co.
 17 W. 60th St. N. Y. City

Size 16" high, 7" wide, 3 1/2" deep. Weight 12 pounds.

10 CENTS RADIO BOOKS

Finest, new radio books for experimenters. Each book contains over 15,000 words and dozens of illustrations. No. 1—HOW TO BUILD FOUR GERLE SHORT-WAVE SETS. No. 2—HOW TO BUILD SIX 1-AND-2-TUBE ALL-WAVE SETS. No. 3—ALTERNATING CURRENT FOR BEGINNERS. No. 4—ALL ABOUT AERIALS. Send 10c coin or U. S. Stamps for each book. We pay postage. Money back if not satisfied. Order by number.

RADIO PUBLICATIONS
 101 Hudson Street New York, N. Y.

RADIO PUBLICATIONS SWC-1236
 101 Hudson Street, New York, N. Y.

Enclosed you will find my remittance of _____ cents for which you are to send me, POSTPAID, the books whose numbers I have checked below.

1 2 3 4

Name _____
 Address _____
 City _____ State _____

Please mention SHORT WAVE CRAFT when writing advertisers

Here are the Six BEST SHORT-WAVE RADIO BOOKS!

Without doubt you will have to go a long way to buy better books on short waves than you find on this page. Each book is written by a well-known authority on short waves . . . each book has been carefully illustrated with photographs and diagrams to

make the study of this field of radio much simpler. The volumes on this page are the finest books on short-waves which are published anywhere today. Order one or more copies today . . . find out for yourself how fine they are. Prices are postpaid.

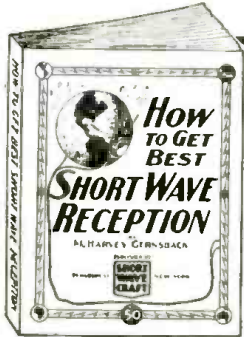

How to Get Best Short-Wave Reception

By M. HARVEY GEHNSBACK

This book tells you everything you ever wanted to know about short-wave reception. The author, a professional radio listener and radio fan for many years, gives you his long experience in radio reception and all that goes with it. Why is one radio listener enabled to pull in stations from all over the globe, even small 100 watters, 10,000 miles away, and why is it that the next fellow, with a much better and more extensive equipment, can only pull in the powerful stations that any child can get without much ado?

- The reason is intimate knowledge of short waves and how they behave. Here are the chapters of this new book:
1. What are Short Waves and what can the listener hear on a short-wave receiver or converter?
 2. How to tune and when to listen in on this short waves.
 3. How to identify short-wave stations.
 4. Seasonal changes in short-wave reception.
 5. Types of receivers for short-wave reception.
 6. Aerial systems for short-wave receivers.
 7. Verifications from short-wave stations.

The book makes excellent reading matter. There are many tricks in short-wave reception that even some of the "old-timers" do not know. Be sure to get it.

40 Illustrations, 72 Pages. Stiff, flexible covers

50c

HOW TO BUILD AND OPERATE SHORT-WAVE RECEIVERS

THIS is the best and most up-to-date book on the subject. It is edited and prepared by the editors of SHORT WAVE CRAFT, and contains a wealth of material on the building and operation, not only of typical short-wave receivers, but short-wave converters as well. Dozens of short-wave sets are found in this book, which contains hundreds of illustrations; actual photographs of sets built, hookups and diagrams galore.

This book is sold only at a ridiculously low price because it is our aim to put this valuable work into the hands of every short-wave enthusiast.

We know that if you are at all interested in short waves you will not wish to do without this book. It is a most important and timely radio publication.

150 Illustrations, 72 Pages. Stiff, flexible covers

50c

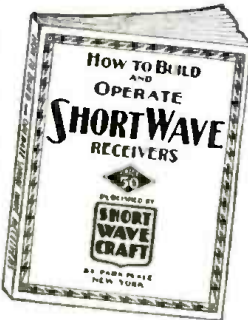

THE SHORT-WAVE BEGINNER'S BOOK

HERE is a book that solves your short wave problems—leading you in easy steps from the simplest fundamentals to the present state of the art as it is known today. It is the only low-priced reference book on short waves for the beginner. The book is profusely illustrated—it is not "technical." It has no mathematics and no technical jargon. It also gives you a tremendous amount of important information, such as time conversion tables, all about aerials, noise elimination, all about radio tubes, data on coil winding and other subjects.

Partial List of Contents

- Getting Started in Short Waves—the fundamentals of electricity. Symbols, the Short Hand of Radio—how to read schematic diagrams. Short Wave Coils—various types and kinds in making them.
- Short Wave Aerials—the points that determine a good aerial from an inefficient one.
- The Transposed Lead-in for reducing static.
- The Beginner's Short-Wave Receiver—a simple one tube set that anyone can build.
- How to Tune the Short-Wave Set—telling the important points to get good results.
- Audio Amplifiers for S-W Receivers.
- Learning the Code—for greater enjoyment with the S-W set. Wave lengths to kilocycle Chart.
- Wire Chart—to assist in the construction of coils.

75 Illustrations, 40 Pages. Stiff, flexible covers

25c

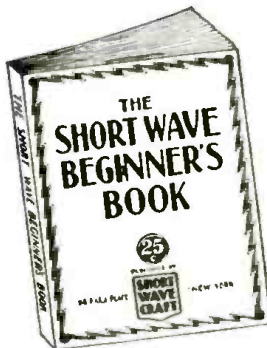

101 SHORT-WAVE HOOKUPS

Compiled by the Editors of SHORT WAVE CRAFT

EACH and every hook-up and diagram illustrated is also accompanied by a thorough explanation of what this particular hook-up accomplishes, what parts are required, coil-winding information, values of resistors, etc., in fact, everything you want to know in order to build the set or to look up the data required.

To be sure, all of the important sets which have appeared in print during the past five years are in this valuable book. Sets such as the Doerle, Hummer, the "Big" Twainies, Oscillodyne, Denton "Stand-by," Mecadyne Triplet 2, "Globe-Trotter," 2-Tube Superhet, "Mindyde," Loop Receiver, "Dorie," 2-Tube Battery, "Dorie," 3-tube Battery, "Dorie," 2-tube A.C., "Dorie," 3-tube A.C. Doerle "Signal Gripper," Duo R.F. 4-tube Receiver, The Sargent 9-33 Tapped Coil Receiver, Globe-Circuit 7, The 2-Tube "Champ"—2 Tube Equal 3, Ham-Band "2-Tube Peerless" "Wash All-Way 8, Denton Economy 3, 2-Tube "Regenerative Oscillodyne" will be found here, with full descriptions. In many cases, we have also included a picture hook-up for those who do not wish to follow the regular symbolic hook-up, but wish to have a regular wiring diagram.

This is a very handy volume, especially for those "fans" who wish to study the best sets in the short-wave art, from one tube up to ten tubes.

100 Illustrations, 72 Pages, 50c Stiff, flexible covers

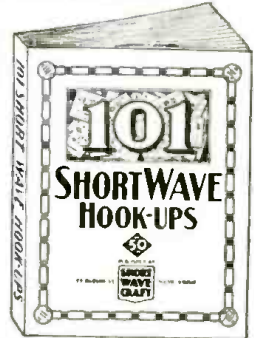

HOW TO BECOME AN AMATEUR RADIO OPERATOR

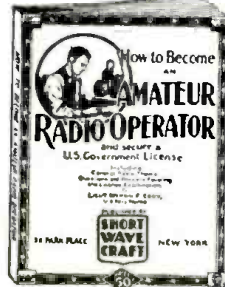

WE chose Lieut. Myron F. Eddy to write this book because his experience in the amateur field has made him prominent in this line. For many years he was instructor of radio telegraphy at the R.C.A. Institute. He is a member of the I.R.E. (Institute of Radio Engineers), also the Veterans Wireless Operators Association.

If you intend to become a licensed radio operator, if you wish to take up phone work eventually—this is the book you must get.

Partial List of Contents

Ways of learning the code. A system of sending and receiving with approved drill words is supplied so that you may work with approved methods. Concise authoritative definitions of radio terms, units and laws, brief descriptions of commonly used pieces of radio equipment. This chapter gives the working terminology of the radio operator. Graphic symbols are used to indicate the various parts of radio circuits. General rules (especially as it applies to the beginner) are explained and typical basic circuits are analyzed. Descriptions of modern receivers that are being used with success by amateurs. You are told how to build and operate these sets. Amateur transmitters. Diagrams with specifications are furnished so construction is made easy. Power equipment that may be used with transmitters and receivers, rectifiers, filters, batteries, etc. Regulations that apply to amateur operators. APPENDIX which contains the International "Q" signals, conversion tables for reference purposes, etc.

150 Illustrations, 72 Pages, Stiff, flexible covers

50c

TEN MOST POPULAR SHORT-WAVE RECEIVERS

—HOW TO MAKE AND WORK THEM

THE editors of SHORT WAVE CRAFT have selected ten outstanding short-wave receivers and these are described in the new volume. Each receiver is fully illustrated with a complete layout, pictorial representation, photographs of the set complete, hookup and all worth-while specifications. Everything from the simplest one-tube set to a 5-tube T. S. F. receiver is presented. Complete lists of parts are given to make each set complete. You are shown how to operate the receiver to its maximum efficiency.

CONTENTS

- The Doerle 2-Tube Receiver That Reaches the 12,500 Mile Mark, by Walter C. Dyerle.
- 2-R.F. Pentode S-W Receiver having two stages of Tuned Radio Frequency, by Clifford E. Denton and H. W. Secor.
- My de Luxe S-F Receiver, by Edward G. Ingram.
- The Binneweg 2-Tube 12,000 Mile DX Receiver, by A. Binneweg, Jr.
- Build a Short-Wave Receiver in Your "Brief-Case," by Hugo Gehnsback and Clifford E. Denton.
- The Denton 2-Tube All-Wave Receiver, by Clifford E. Denton.
- The Denton "Stand-By," by Clifford E. Denton.
- A COAT-POCKET Short-Wave Receiver, by Hugo Gehnsback and Clifford E. Denton.
- The S-W PENTODE 4, by H. C. Clain, M. E.
- Louis Martin's Idea of A GOOD S-W RECEIVER, by Louis Martin.

75 Illustrations, 40 Pages, 25c Stiff, flexible covers

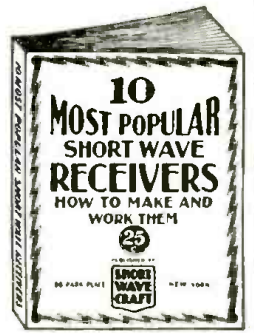

All the books shown on this page are published exclusively by

SHORT WAVE CRAFT

99-101 Hudson Street New York, N. Y.

CLIP-MAIL

SHORT WAVE CRAFT, 99-101 Hudson Street, New York, N. Y. SWC-12-36

Gentlemen: I enclose herewith my remittance for the amount of \$..... for which you are to send me, postpaid, the books checked below.

- How to Get Best Short-Wave Reception..... 50c each
- 101 Short-Wave Hook-ups..... 50c each
- How to Build and Operate Short-Wave Receiver..... 50c each
- How to Become an Amateur Radio Operator..... 50c each
- Ten Most Popular Short-Wave Receivers. How to Make and Work Them..... 25c each
- The Short Wave Beginner's Book..... 25c each

Name.....
Address.....
City..... State.....

(Send remittance in form of check or money order. If letter contains cash or unused U. S. Postage Stamps, reclear it.)

OVERSEAS READERS!

These books can be obtained from the following houses:

GREAT BRITAIN
Gorringe's
9a, Green Street, Leicester Square
London, England

FRANCE
Editions Radio
42 Rue Jacob
Paris

AUSTRALIA
McGill's
183-195, 218 Elizabeth St.
Melbourne, C. I.

Please mention SHORT WAVE CRAFT when writing advertisers

Statement of the Ownership, Management, Circulation, etc., Required by the Acts of Congress of August 24, 1912 and March 3, 1933

Of Short Wave Craft, published monthly at Mount Morris, Illinois, for October 1, 1936. State of New York, County of New York.

County of a Notary Public in and for the State and county aforesaid, personally appeared Hugo Gernsback, who, having been duly sworn according to law, deposes and says that he is the Editor of the Short Wave Craft and that the following is, to the best of his knowledge and belief, a true statement of the ownership, management (and if a daily paper, the circulation), etc., of the aforesaid publication for the date shown in the above caption, required by the Act of August 21, 1912, as amended by the Act of March 3, 1933, embodied in section 537, Postal Laws and Regulations, printed on the reverse of this form, to wit:

1. That the names and addresses of the publisher, editor, managing editor, and business managers are: Publisher, Popular Book Corp., 99 Hudson Street, N.Y.C.; Editor, Hugo Gernsback, 99 Hudson Street, N.Y.C.; Managing Editor, H. Winfield Secor, 99 Hudson Street, N.Y.C.; Business Managers, None.

2. That the owner is: (If owned by a corporation, its name and address must be stated and also immediately thereunder the names and addresses of stockholders owning or holding one per cent or more of total amount of stock. If not owned by a corporation, the names and addresses of the individual owners must be given. If owned by a firm, company, or other unincorporated concern, its name and address, as well as those of each individual member, must be given.) Popular Book Corp., 99 Hudson Street, N.Y.C.; H. Gernsback, 99 Hudson Street, N.Y.C.; H. Winfield Secor, 99 Hudson Street, N.Y.C.

3. That the known bondholders, mortgagees, and other security holders owning or holding 1 per cent or more of total amount of bonds, mortgages, or other securities are: (If there are none, so state.) None.

4. That the two paragraphs next above, giving the names of the owners, stockholders, and security holders, if any, contain not only the list of stockholders and security holders as they appear upon the books of the company but also, in cases where the stockholder or security holder appears upon the books of the company as trustee or in any other fiduciary relation, the name of the person or corporation for whom such trustee is acting, is given; also that the said two paragraphs contain statements embracing affiant's full knowledge and belief as to the circumstances and conditions under which stockholders and security holders who do not appear upon the books of the company as trustees, hold stock and securities in a capacity other than that of a bona fide owner; and this affiant has no reason to believe that any other person, association, or corporation has any interest direct or indirect in the said stock, bonds, or other securities than as so stated by him.

5. That the average number of copies of each issue of this publication sold or distributed, through the mails or otherwise, to paid subscribers during the twelve months preceding the date shown above is..... (This information is required from daily publications only.)

HUGO GERNSBACK, Publisher.
Sworn to and subscribed before me this 21th day of Sept. 1936.
MARTINE COYNE, Notary Public.
(Seal) (My commission expires March 30, 1934.)

CLASSIFIED

Advertisements are inserted at 5c per word to strictly amateurs, or 10c a word to manufacturers or dealers. Each word in a name and address is counted. Cash should accompany all orders. Copy for the January issue should reach us not later than November 5.

<p>GENERATORS</p> <p>TURN SCRAP INTO MONEY. Autopower shows you how easily and economically auto generators can be converted into A.C. or D.C. generators and D.C. motors, 2 to 1000 volts; for sound, radio, power, light, or welding. No previous experience necessary—complete instructions in new book, with simple instructions and illustrations. Endorsed by thousands. Only \$1.00 postpaid. Autopower, Inc., 411-G So. Hoyne Ave., Chicago.</p>	<p>WOULD LIKE TO EXCHANGE</p> <p>Sargent Pre-selector for Master Telex Code Teaching Machine, or National SW3. Robert Ireland, Pleasant Valley, N. Y.</p> <p>LATE 1935 EIGHT TUBE SIMPLEX superhet 13-2000 meters. Fine set, complete \$23 cash. Richard Parsons, Bramwell, W. Va.</p> <p>SELL-SWAP 59 consecutive issues S.W.C. Also 45 QST. Want good miniature camera. Rex Ackley, 421 Wayne, Johnstown, Penna.</p> <p>EILEN FIVE BANDSWITCH. New, never used. Complete \$9.75. C. Gerst, 2674 W. 25th, Cleveland, Ohio.</p> <p>MASTERPIECE IV—ONE ONLY. Bargain. Like new. Mr. Baltzly, 1711 Riverside, Muncie, Indiana.</p>	<p>RADIO EQUIPMENT</p> <p>THE "KEY OF SUCCESS." Our line of standard and high-speed telegraph keys is world-famous. Best amateur discounts. Write today for free information. Universal Radio, Dept. R 8, Box 40, San Francisco, California.</p> <p>ELECTRICAL EXPERIMENTERS! Construct Power and Test Panel and 10,000 V. Tester. Both plans. Complete, 25¢ coin. Robert Dieter, Box 262, West Chicago, Illinois.</p>
<p>CODE MACHINES</p> <p>OMNIGRAPH EXPERT TEACHER. Automatic, learn quickly, in half time. Small course. Metal code dials exchanged free. Thousands satisfied. Buy or rent. CQ call dials made to order. Booklet, Omnigraph Mfg. Co., 810 East 39th St., Brooklyn, N. Y.</p>	<p>INSTRUCTION</p> <p>AMATEUR RADIO LICENSES, complete training. Resident and correspondence courses. Every graduate a licensed operator. N. Y. Wireless School, 1123 Broadway, New York.</p>	<p>RADIOS</p> <p>FARM AND CITY RADIOS. \$6.95 up; save over 60 per cent; amazingly new farm radio; operates from free windpower; new farm power or battery. Lowest cost electric lights. Agency-clean up; catalog; free offer. Marco Company, 260 E. 14th, Kansas City, Mo.</p>
<p>CURIOS</p> <p>INDIAN RELICS, BEADWORK, Coins, Books, Curios, Fossils. Catalogue, 5c. Indian Museum, Northbranch, Kansas.</p>	<p>MISCELLANEOUS</p> <p>OHM'S LAW CALCULATOR—Lightning Slide Rule; solves all problems of Voltage, Current and Resistance. Power, Wire Sizes, etc. Range: 1 micro-amp. to 1000 amps.; 1 micro-volt to 10,000 volts; 1 micro-ohm to 10 megohms; 1 micro-watt to 10 megawatts; wire sizes 0 to 36 B. & B. gauge. Introductory price \$1.00 prepaid. The Dataprint Co., Box 322, Ramsey, N.J.</p>	<p>SHORT WAVE COMPONENTS</p> <p>PLUG-IN COILS, 15-210 METERS. Shave wound on standard four prong forms. 35¢ set postpaid. Noel, 728 Birch, Scranton, Pa.</p>
<p>"HAM" OFFERS AND WANTS</p> <p>FOR SALE: READRITE ALL-WAVE Signal Generator Model 554-A \$8.75. Triplet Volt-ohm Milliammeter Model 1200-A \$12.50. Triplet unit case for two \$2.50. Thoriarosh Condenser Tester \$1.00. Gross C. P. 25 CW Transmitter out 25-30 watts. All in A-1 condition. Mayford Ogle, Gatlinburg, Tenn.</p> <p>FOR SALE: BARGAIN—300 WATT Phone and C.W. Transmitter—complete in Rack—160 and 80 meters—Crystal Control. Guaranteed Excellent Condition. First \$135 gets it. Cohen, 5208 13th Ave., Brooklyn, N. Y.</p> <p>SELL—ALL-STAR JRL SUPER. 8-550 meters, excellent condition, complete with extras, reasonable. For details, write H. Stark, Box 177, Chihuahua, B.C. Canadian enquiries solicited.</p>	<p>QSL—CARDS—SWL</p> <p>SHORT WAVE LISTENER'S Attractive Reply getting cards. QSLs, Samples (Stamps). W-8-E-8-N, 1827 Cone, Toledo, Ohio.</p> <p>QSL SWL CARDS, NEAT, Attractive, reasonably priced, samples free. Miller, Printer, Ambler, Pa.</p> <p>QSL CARDS, NEW STYLE. Reasonable Price, Samples. Becker Bros., Port Chester, N. Y.</p>	<p>SHORT WAVE RECEIVERS</p> <p>RECEIVERS—NEW AND USED, sold and traded in. Hammarlunds, Nationals, RME, Sky Rider, Schwarz Radio Service, 15 Lawrence Ave., Dumont, N. J.</p> <p>SW CRYSTAL SET—4250 MILES record. Blueprint 18 Distance Models; "Radiobuilder" year; 25¢. Laboratories, 151-A Liberty, San Francisco.</p> <p>IN STOCK—NEW NATIONAL NC-100 \$110, SW3 \$19.50, 1 used SW5 \$13.00. Schwarz Radio, Dumont, N.J.</p>
		<p>WIND ELECTRIC PLANTS</p> <p>BUILD WIND LIGHT PLANT from automobile generator. Dimo brings complete plans and catalogue. Over 50 other generator changes. LeJay Manufacturing, 1417 Lake, Minneapolis, Minn.</p>

YOU CAN'T BUY THIS BOOK



SHORT WAVE GUIDE

With Your \$1.00 subscription to Short Wave Craft You Get This Brand New Book **FREE**

The special subscription rate is 7 months for \$1.00. (Regular newsstand rate is \$1.75.)

Send the coupon today, with your remittance of One Dollar (\$1.00). When your subscription is received, a copy of our SPECIAL ANNIVERSARY GIFT will be sent to you—**POSTPAID!**

You do not have to be a new subscriber to receive this gift. If you are a subscriber at present, a copy of "SHORT WAVE GUIDE" will be sent you upon receipt of \$1.00, and we will advance your subscription by seven months.

because it is our **Sixth Anniversary**

FREE GIFT to YOU!

This year, SHORT WAVE CRAFT celebrates its Sixth Anniversary. Annual increases in circulation, plus authentic, exclusively short-wave editorial material, makes SHORT WAVE CRAFT unquestionably the leading magazine in its field. To commemorate this notable occasion, the Editors have written this outstanding book.

Partial Contents of Short Wave Guide

Short-Wave Questions and Answers

It is impossible to publish each month in SHORT WAVE CRAFT all the questions (and their answers) sent to us. We have printed with full illustrations, in SHORT WAVE GUIDE hundreds of important questions which have been recently received.

Short-Wave Kinks, Illustrated

Every short-wave fan is interested in new kinks and shortcuts. Dozens of kinks reach us every week—and in SHORT WAVE GUIDE you will find a variety of them, carefully illustrated. They will prove very valuable to you.

Simple, Efficient Short-Wave Receivers Which Anyone Can Build

Complete constructional plans for building many 1, 2 and 3-tube receivers will also be found. Schematic diagrams, lists of parts—everything you need to know to build these sets and make them function properly is included.

Best Aerials for Short-Wave Reception

The many elaborate antennas suitable for short-wave reception often present problems for set owners. SHORT WAVE GUIDE will help you decide which aerial is best for your receiver. Many types of antennas are illustrated.

Practical Hints on Short-Wave Tuning

Hundreds of short-wave stations are heard by fans—and hundreds more could be heard distinctly if only you knew more about tuning them in. Expert advice on proper tuning is included in SHORT WAVE GUIDE.

"Police Call" Receiver and How to Build It

The most stirring signals on the air are police calls and every fan wants to hear these exciting alarms. Complete details for building and operating a "police call" receiver will be found.

A Simple "Ham" Transmitter

There are thousands of fans who want to build a simple transmitter. Here is the ideal transmitter for beginners. It is practical, yet inexpensive to construct. List of necessary parts, wiring diagrams, and construction details are included.

SHORT WAVE CRAFT, 99G Hudson Street, New York, N. Y. 12

Gentlemen: Enclosed you will find my remittance of ONE DOLLAR (\$1.00) (Canada and Foreign \$1.30) for which enter my subscription for Seven Months to SHORT WAVE CRAFT. You are also to send me absolutely FREE, and postpaid, a copy of the Special Anniversary Gift Book—SHORT WAVE GUIDE.

Name

Address

City

New Subscriber Old Subscriber

Send remittance in form of check, money order or unused U. S. Postage Stamps. (Foreign: International Postal Money Order.) Register letter if it contains cash or stamps.

Please mention SHORT WAVE CRAFT when writing advertisers

www.americanradiohistory.com

Nationally Known 6 1/2 inch DYNAMIC SPEAKERS

1500 ohms. Output transformer to match 38, 12A7, 71A, 43, 45, 2A5, 47, 59, 53 tubes, etc. Shipping weight 6 lbs. AD 600, AD-600 Speaker complete.

- SAME SPEAKER—**
 10 1/4 inch, available in the following sizes:
 1000, 1500, 2000 ohm field coils. Brand new, less output transformers. **\$1.95**
 10" SPEAKER less transformer..... **25c**
OUTPUT TRANSFORMERS, extra
 10" 45-2A5..... **39c**
OUTPUT TRANSFORMERS, single
 pentode, extra..... **39c**
 AD-1601 Shipping weight, 10 lbs.

89°C

As Illustrated

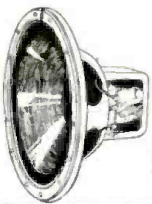

BUILD IT YOURSELF

GREATEST AMPLIFIER BARGAIN EVER OFFERED
40 WATT Undistorted Power Amplifier

EMPLOYS NEW RCA MIRACLE TUBE DEVELOPMENT. 5L6 BEAM POWER OUTPUT TUBES

Multiple input channel; velocity microphone 130 DB; crystal microphone 12 DB; carbon microphone 90 DB; phonograph pick up 75 DB. One or two speakers (please specify). Through high fidelity response. Variable bass compensator. Universal output transformer with variable impedance from 4 to 300 ohms. Employs new metal 6 tubes, 2-6F5; 1-6C6; 2-6L6; 1-5Z3.

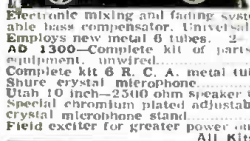

- AD 1300—Complete kit of parts, with drilled shielded and screened chassis. Less equipment, unwired..... **\$19.95**
 Complete kit 6 R. C. A. metal tubes..... **5.09**
 Complete kit 6 R. C. A. metal tubes..... **13.23**
 Shure crystal microphone..... **6.95**
 Utah 10 inch—2500 ohm speaker to match special chromium plated adjustable crystal microphone stand..... **7.95**
 Field exciter for greater power output..... **3.95**
 AD 1301—Amplifier wired complete, less tubes..... **\$24.95**
 AD 1302—12-20 Watt 6F6 Amplifier Kit..... **16.95**
 AD 1303—15 Watt 6B5 Amplifier Kit..... **15.95**
 AD 1304—22 Watt 6B5 Amplifier Kit..... **17.95**
 All Kits Less Tubes, Speakers and Microphones

4-Tube 7 1/2 Watt Amplifier Kit

A beautifully designed amplifier, conservatively rated at 7 1/2 watts. Comprises two stages—one utilizing a 57 input tube and the other a parallel stage using 2-2A5's. Uses an 80 rectifier. Input to grid of 57. Output from plates of 2A5. Designed for 100 to 130 volts, 50-60 cycles. A.C. knife system fuse protected. Sold complete with all parts: chassis, wire, hardware, etc., ready to assemble and wire. Detailed diagram included. Ship wt. 15 lbs.

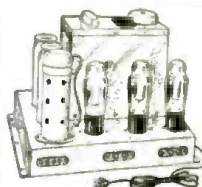

- No. AD 112 7 1/2 Watt Amplifier Kit, less tubes, unwired..... **\$4.95**
 Amplifier, Completely Wired..... **\$1.00 extra**

Complete Public Address Combination

- This combination comprises:
 Completely Wired and Tested 7 1/2 Watt Amplifier, described above..... **\$5.95**
 Paragon Double Button Professional Carbon Mike..... **\$2.95**
 Paragon Professional Double Button Mike..... **\$3.95**
 1—Telescopic Chromium Plated Microphone Floor Stand..... **\$3.95**
 1—10" Dynamic Speaker..... **\$2.29**
 1—Microphone Input Box..... **\$2.95**
 1—Set of Matched Tubes..... **\$1.95**
Complete System..... \$16.95
 Add \$1.00 extra for Paragon Mike—Add 5c per ft. for 3-wire shielded mike cable—Add 6c per ft. for 4-wire shielded speaker cable.

NO ORDER FOR LESS THAN \$1.00 WILL BE ACCEPTED. ALL REMITTANCES MUST INCLUDE A SUFFICIENT AMOUNT TO COVER POSTAGE AND INSURANCE. NO C.O.D. ORDERS FILLED UNLESS ACCOMPANIED BY A 25% DEPOSIT.

What Is It?

Radio Experimenter's Surprise Package

A large box chock full of assorted radio parts, worth over \$10.00—parts that any radio experimenter and set builder can use. All brand new—no junk. Weight 20 lbs.

- Surprise Kit—AD-1260..... **\$1.29**
 Giant Surprise Kit, weight 40 lbs..... **\$2.50**



R. M. A. Color Coded Carbon Resistors

These are all Brand New Stock. 100 Assorted sizes 50 ohm—5 meg ohm. 1/2, 1 watt sizes. Guaranteed 10% accuracy resistors. Complete assortment **\$1.29**
 100 resistors..... **3c**
 AD 185—shipping weight 4 lbs.

Hum Free Power Supply Pack

This Pack will supply 2.5 volt Filament voltage. Pure Rectified I.C. 350 volts at 80 MILS 6 AMPS for Filament. Same Pack supplies 6-7 tubes at 6.3 volts..... **\$2.95**
 Same Pack supplies 8-9 tubes at 6.3 volts..... **\$3.39**
 Same Pack supplies 10-12 tubes at 6.3 volts..... **\$4.25**

- Complete Kit **\$2.49**
 with wiring diagram and drilled chassis less tube, unwired. Wiring 50c extra. Tube extra 34c. Shipping weight, 12 lbs.

PRESTO PHONOGRAPH PICK UP

High Impedance. Brand new. 12" self-balancing arm. List price \$10.00. Special price while they last **\$3.75**
 AD-1309X

Midget Variable Condensers

Excellent for use as antenna trimmers in short-wave sets and as vernier tuning condensers. Capacity approximately 20 mmf. Sold complete with knob and pointer. Single hole mounting. 9 solid brass plates. Ship. wt. 1/2 lb. No. AD-117 YOUR PRICE **25c**

Yaxley Band-Changing Switch

Designed especially for all-wave sets. Heavy silver plated contacts. Consists of six 2-gang decks—12 gangs in all. Three positions. Excellent for short-wave as well as for analyzers. List price \$4.32. Ship. wt. 1 lb. No. AD-111..... **29c**
 AD 112A. Three double sections for use on 5 band all wave radios—5 steps—can be adjusted to 12 steps..... **49c**

CCA Wet Electrolytic Filter Condenser

- | | |
|-----------|-----|
| 500 Volts | |
| 4 MFD | 20c |
| 6 MFD | 23c |
| 8 MFD | 25c |
| 10 MFD | 35c |
| 12 MFD | 38c |
| 14 MFD | 40c |
| 16 MFD | 45c |

MICA BY PASS CONDENSERS

1000 volt test, 600 working volts. Available in the following sizes:
 .0001 .0015 .0025
 .0007 .0001 .003
 .001 .0002 .00025
 .002 .0003
 Special price while they last. In lots of 100..... **\$0.95**
 50 for..... **.60**
 Single units..... **.03**
 AD1311

SPECIAL TUBE OFFER

DILCO R. C. A. Licensed
100% Triple Tested TUBES
YOUR CHOICE ANY GROUP ONLY \$1.00

Quan.	Type	Quan.	Type	Quan.	Type
3	50	4	31	4	82
2	12A7	12	71A	4	616
3	2A3	6	56	4	523
12	27	2	16	4	33
12	26	4	24A	6	46
6	01A	4	51	4	1A6
6	12A	4	36	4	484
4	30	4	47	3	485

666 RECTIFIERS..... **89c**
 6E5-6G5 Magic Eye..... **2 for \$1.00**
 New 6B5 high output audio tube, 2 for..... **\$1.00**

Also these new metal glass Octal base tubes.
 1 H 7 5 Y 3 6 F 7
 1 D 5 6 H 6 5 Z 4
 1 D 5 6 K 7 6 A 8
 1 C 7 6 A 6 5 Z 5
 1 F 5 6 Z 5
 25 A 6 1 H 4 6 P 5
 6 C 5 1 H 6 6 P 6
 6 L 7 1 J 6 25 Z 6

Output Transformer for Dynamic Speakers

Matches any speaker, voice coil for 4 to 15 ohms, push pull for pentode triode tubes. AD105 **25c**

AC-DC Filter Chokes

Small, compact units designed for use in AC-DC midjet sets. Will pass 60 mls. No. AD-110 YOUR PRICE **25c**

AD-491 CRL Volume Control Potentiometer

5,000 25,000 50,000 100,000 ohm **25c**

2 1/2 MH. SHORT WAVE R. F. CHOKE 15c

These low loss Chokes are used in every S. W. Set. Complete parts in stock for all diagrams appearing in Short Wave Craft, Radio Craft, QST, Popular Mechanics, etc.

Two & Three-Gang Midget Tuning Condensers

Midget variable condenser cap. 0.00165 MFD 3 gang has 3/8" shaft AD113 3 gang **59c**
 AD 113A 2 gang..... **59c**

Universal Output Transformer

A real output transformer that will handle the output of any PA system. Secondary impedances variable, from 1/2 ohm in steps up to 500 ohms. Primary will match any tube in triode, pentode, push-pull, parallel or single output. Impedances will match the new 6B5 and all other output tubes on the market. Excellent audio response. Color coded chart with each. Shipping weight, 5 lbs. AD 104..... **\$1.49**

FREE 64-page catalog and treatise. Send stamp for our FREE treatise and catalog which contains much valuable data and radio information. There is no obligation involved. Absolutely free. Book sent by return mail.

BUILD YOUR OWN RADIO SETS

5-Tube Super Hot Kit

Comprising of 1 oscillator, 2-456 KC Double Tuned I-F Transformers—1 Antenna coil, 1-2 gang oscillator tracking condenser, complete with 1.75 wiring diagram, ready to use..... **\$1.75**

Drilled Chassis to Match 29c
 Kit of other essential parts, complete set including condensers, resistors, choke filter, volume control, nuts, bolts, etc. AD-900—Super Hot Kit. Complete **\$2.39**
 Less tubes..... **2.25**
 AD-900A Individual 456 K. I. F. Transformer 49c
 Set of Five Matched Tubes **\$2.95**

4-TUBE TRF KIT

4-tube TRF circuit operates on AC-DC current. Complete parts with wiring diagram, ready to wire with speaker, hardware, etc., less tubes and cabinet..... **\$4.95**
 Kit completely wired, extra..... **\$1.00**
 Same kit, magnetic speaker..... **4.49**
 Kit of 4 tubes..... **2.25**
 AD 204 Walnut cabinet to match..... **1.75**

13 Contact Cam Switch

Same switch as above, 21 Contact..... **9c**

AUTO RADIO VIBRATOR

Ideal for replacement or may be used to construct an Auto Radio "B" Eliminator. AD-7716—49c

BANDSPREAD VARIABLE CONDENSERS

Available with 11 plates. (approx. .00025 mfd); 13 plates. (.0003 mfd); 17 plates. (.000365 mfd); 23 plates. (.0005 mfd); 46 plates. (.001 mfd). For short-wave bandspread receivers as well as for standard broadcast and long-wave receivers. Ship. wt. 2 lbs. No. AD-116 Variable Condensers—each..... **25c**

G. E. POWER TRANSFORMER

Manufactured by General Electric. A well designed transformer. Has 6.3 volt filament winding. Designed for 110-125 volts. 50-60 c. A.C. Specifications: 6.3 V. 2 1/2 amp.; 5 V. 2 amp. for 81, or 80 tube; 7.50 V. C.T., 7.5 mls. for plate current. Ship. wt., 5 lbs.; also available in 2 1/2 V. No. AD-101, 6 to 7 tube..... **99c**
 No. AD-102, 7 to 8 tube..... **\$1.49**
 No. AD-103, 8 to 10 tube..... **\$1.96**
 Transformer, 125 mls..... **1.15**
 Unshielded power transformer. Same type as illustrated above, 4.3 fil. volts only.
 AD 201—5-tube unshielded transformers..... **5.65**
 AD 202—8-tube unshielded transformers..... **.85**
 AD 203—10-tube unshielded transformers..... **1.15**

RADIO BOOKS, published by the RCA Institute, Radio Telegraphy and Telephony, Vacuum Tubes, Modern Radio Operation, Preparatory Mathematics relating to Radio, Acquiring the Code. Average value of these books—over \$2.00 each **25c PER VOLUME**

UNITED RADIO COMPANY

Successors to Radio Trading Company

58 MARKET STREET Dept. S-12 NEWARK, N. J.

Please mention SHORT WAVE CRAFT when writing advertisers

YOU MUST HAVE THIS BOOK

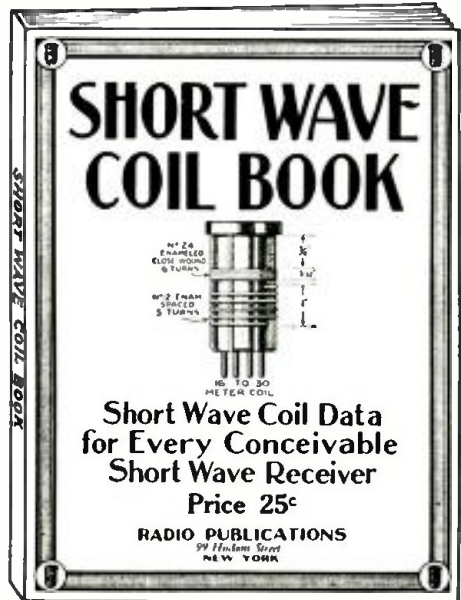

FRIENDS PESTER HIM

Dear Sirs:

I received your Short Wave Coil Book and am very well pleased. I showed it to my radio friends and now they are always pestering me for coil data, hi hi!

BERNARD A. DECKELMANN,
11348 No. State St., Chicago, Ill.

Radio Publications, 97 Hudson Street, New York, N. Y. 12-36

Please send immediately your Short Wave Coil Book, for which I enclose 25¢ herewith (coin, U. S. stamps or money order acceptable). Book is to be sent prepaid to me.

Name.....

Address.....

City and State.....

IT is now possible for the experimenter and short wave enthusiast to obtain the most exhaustive data on short wave coil winding information that has ever appeared in print.

As every experimenter who has ever tried to build a short wave set knows only too well by experience, the difference between a good and a poor receiver is usually found in the short wave coils. Very often you have to hunt through copies of magazines, books, etc., to find the information you require.

Between the two covers of this book you now find every possible bit of information on coil winding that has appeared in print during the past two years. Only the most modern "dope" has been published here.

No duplication. Illustrations galore, giving not only full instructions how to wind coils, but dimensions, sizes of wire, curves, how to plot them, by means of which any coil for any particular short wave set can be figured in advance, as to number of turns, size of wire, spacing, etc.

There has never been such data published in such easy accessible form as this.

Use Coupon Above for Ordering Your Copy

RADIO PUBLICATIONS
97 Hudson Street, New York, N. Y.

Index to Advertisers

A	N
Ace Radio Laboratories.....494, 513	National Company, Inc.....Inside Back Cover
Allied Engineering Institute.....504, 506	National Radio Institute.....510, Back Cover
Allied Radio Corp.....503	National Schools.....510
American Microphone Co.....515	New York Y.M.C.A. Schools.....511
American Television and Radio Co.....507	O
Arrow Sales Corporation.....508	Ohmite Manufacturing Co.....513
Astatic Microphone Laboratory, Inc.....504	P
B	Par-Metal Products Corp.....500
Brush Development Co., The.....513	Peak Radio Products.....500
Hud Radio, Inc.....506	Pierce-Airo, Inc.....495
Burstein-Appiebee Co.....508	Pilot Radio Corporation.....520
C	R
Cameradio Co.....505	Radio & Television Institute.....511
Candler System Co.....510	Radio Constructors Laboratories.....497
Centrallion Engineering Co.....519	Radio Publications.....514, 515
Classified Advertisements.....517	Radio Service Inst.....511
Coyne Electrical & Radio School.....459	Radio Training Assn. of America.....510
Crosley Radio Corp., The.....502	Radolek.....519
D	Ramsey Publishing Co.....511
Dataprint Company.....508	RCA Institutes, Inc.....510
Deutschmann, Tobe, Corp.....515	Rextron.....513
Dodge's Institute.....511	S
E	Sargent, E. M., Co.....507
Eilen Radio Laboratories.....493	Schwarz Radio Service.....515
Electrad, Inc.....515	Short Wave Coil Book.....519
F	Silver, McMurdo Corp.....508
First National Television, Inc.....510	South Bend Lathe Works.....509
G	Sprayberry Academy of Radio.....505
Gold Shield Products Co.....515	Superior Instruments Co.....509
Goldentone Radio Co.....503	Supreme Instruments Corp.....460
Guy Stokely Radio Corp.....501	T
H	Teleplex Co.....506
Hallcrafters, Inc.....499	Triplett Electrical Instrument Co.....504
Hammarlund Manufacturing Co., Inc.....500	Try-Mo Radio Co., Inc.....498
Harrison Radio Company.....496	U
I	Ultra High Frequency Products Co.....500
Instructograph Company.....511	Uncle Dave's Radio Shack.....498
Insuline Corp. of America.....509	Universal Microphone Co., Ltd.....503
K	United Radio Company.....518
Kelsey Co., The.....513	W
Kenyon Transformer Co., Inc.....496	Wellworth Trading Company.....515
Korrol Mfg. Co., Inc.....508	Wholesale Radio Service Co., Inc.....457
L	Winn, J. H., Mfg. Co.....509
Lancaster, Allwine & Rommel.....509	Z
Lifetime Corp., The.....509	Zephyr Radio Co.....505
Linguaphone Institute.....504	(While every precaution is taken to insure accuracy, we cannot guarantee against the possibility of an occasional change or omission in the preparation of this index.)
Mc	
McElroy, T. R.....510	
M	
Massachusetts Radio School.....510	
Metal Cast Products Co.....519	
Midwest Radio Corp.....Inside Front Cover	

Keep Your Customers Satisfied

USE **RADOLEK SERVICE**

... Plus This Most Complete Radolek Radio Buying Guide

The Radolek New 1937 Radio Profit Guide is the most complete Radio Parts Catalog ever published. Completely revised—right up to the minute, bringing you everything in Radio—and Public Address—at the right prices. Every page brings you extra profits! Contains over 10,000 Individual Radio Repair Parts—hundreds of new items—a complete new selection of Radio Receivers, P.A. Amplifiers, Tools, Tubes, Books and instruments. Over 160 pages! Everything you need—always in stock—ready for prompt shipment to you. You need this Big Radio Parts Catalog—it's FREE. Send for it! NOW!

RADOLEK
638 W. Randolph—Chicago

Name.....
Address.....
Serviceman? Dealer? Experimenter?

ALL-ELECTRIC 3-TUBE, 4 IN 3

BANDSPREAD SHORT WAVE RECEIVER

A completely electrified receiver capable of worldwide reception. OWNERS REPORT RECEPTION OF AS HIGH AS 35 FOREIGN COUNTRIES. Uses 67 (twin 2 in 1 tube) 76 & 1V tubes in full 4 tube performance circuit as screen-grid regenerative detector, two stage audio frequency amplifier, retainer & built-in hum free power supply. Completely self-contained. Illuminated. Sensitive, powerful, and operates a speaker on many stations. Heavy, black shroud finish metal chassis, panel, and cabinet. Coils for 10-200 meters, and simple instructions furnished. KIT of parts, with 3 coils for 10-200 meters, ready to wire, less tubes, cabinet and B.C. Coils.....\$1.50
Wired and tested, extra.....\$1.50
Matched ARCTURUS tubes (3).....1.98
Beautiful, black finish metal cabinet.....1.28
Broadcast coils (2).....1.00

\$5.95

SPECIAL: Complete kit, cabinet, 4 tubes \$10.95
2 B.C. coils, wired and ready to use.....

BA-3 Three-Tube Battery Operated Receiver HAS SAME APPEARANCE AND CONSTRUCTION AS ABOVE RECEIVER, except that it is operated entirely from dry batteries. Uses 32, 30, 33 tubes in powerful circuit as screen-grid regenerative detector, powerful 2 stage audio frequency amplifier with pentode output stage. Bandspread tuning. Uses one 2 volt A battery, one C battery, and 45 to 90 volts of B battery. Readily operates a loudspeaker. SAME price as All-Electric model. (Less batteries.) Cannonball headphones \$1.35. Magnetic speaker \$1.45

CENTRALLION ENGINEERING CO.
136A Liberty St. New York, N. Y.

WANTED BRANCH MANUFACTURERS

by old established firm, to cast Christmas goods, 5 and 10c Novelties, Toy Autos, Ashtrays, etc. Can be handled in any spare room, basement or garage. No experience necessary as we furnish full instructions with models. A rare opportunity for these times, so if over 21 and you want to devote your spare or full time to profitable work write AT ONCE for full details as we are now closing arrangements for supply of our goods.

METAL CAST PRODUCTS CO.
1696 Boston Road, Dept. 27, New York, N. Y.

Every Radio "Fan" Needs the 1934 and 1935 SHORT WAVE MANUALS.....\$2.50 each. Both bought together.....\$4.50.
SHORT WAVE CRAFT, 99 Hudson St., N.Y.C.

Please mention SHORT WAVE CRAFT when writing advertisers

Recommend this PILOT set to your non-technical BCL friends

\$54.50

Model 193, for AC current
16 to 545 meters

\$49.50

Model 33, for AC current
16 to 52 and 178 to 559 meters

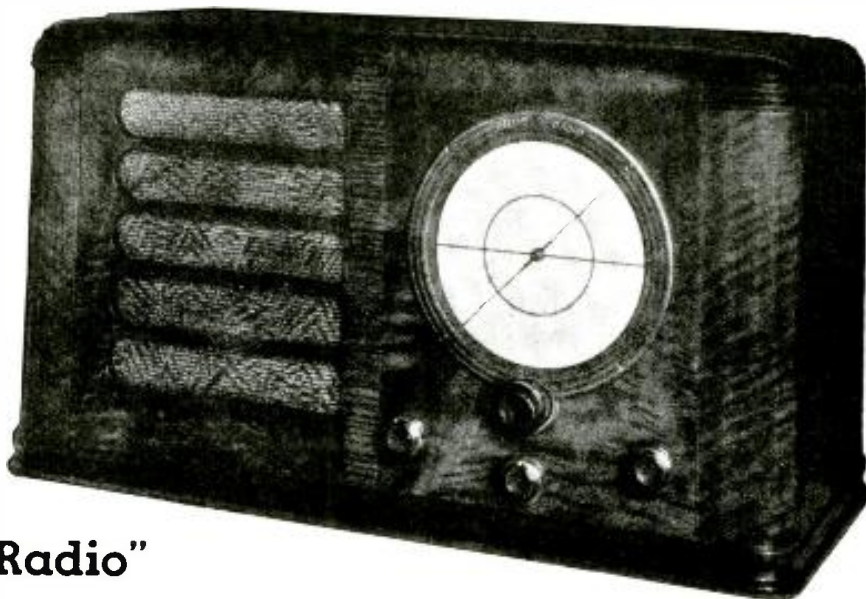

The ideal "Family Radio"

Pilot Model 193 Horizontal Type All-Wave Radio

5-tube, all-wave A.C. superheterodyne, delivers efficiency of 8-tube* receivers

Skillful engineering has made possible the combination of Pilot's traditional high quality and fine performance with a price remarkably low for such a splendid set.

Cabinet: Fine walnut veneers, piano finish, 11 $\frac{3}{4}$ ins. high, 21 $\frac{1}{8}$ ins. wide, 8 $\frac{5}{8}$ ins. deep.

Standard Tuning: Model 193 has three bands, covering 16-51 m. (18,800-5,880 kc.); 48-146 m. (6,250-2,050 kc.); 187-545 m. (1,600-555 kc.).

Extra Large Dial: It's easy to tune with this 6-in. dial.

Stations: All important stations logged on the dial in easy-reading type.

Selective Lighting: Band switch controls lighting of tuning scales.

Gear-Shift Tuning: 2-speed control provides 95:1 or 12:1 ratio.

Superheterodyne: Circuits include all 1937 engineering refinements.

High Power Amplifier: Pentode circuit provides extra range of power.

Diode Detection: Linear rectification maintains tone fidelity.

Tone Filter: Continuously variable audio filter matches response to incoming program.

Automatic Volume Control: Action has been improved by high-sensitivity circuit.

***8-Tube Performance:** This is accomplished by using the 6A8 as 1st detector and oscillator, and combining the 2nd detector, AVC, and 1st audio stage in the 6Q7 tube.

Metal Tubes: One 6A8, one 6K7, one 6Q7, one 6F6, one 5W4.

Interference Rejector: Built-in resonant interference-rejector eliminates code signals.

Complete Shielding: Sealed shielding construction keeps out electrical disturbances.

Rubber Mounting: Vital parts suspended in live rubber shock-proof mountings.

Loudspeaker: 8-in. dynamic speaker with true-response Pilotex cone diaphragm.

Extra Speaker: Socket is provided for connecting extra speaker of 10,000-ohm permanent magnet dynamic type.

Phonograph Jack: For plugging in high-impedance phono pick-up.

Watts Output: 3 watts undistorted output from loudspeaker.

YOU CAN ORDER THIS SET THROUGH YOUR LOCAL RADIO DEALER

"The Standard
of Excellence"

Pilot

In the U.S.A. and
92 Foreign Countries

RADIO CORPORATION

3701 THIRTY-SIXTH STREET, LONG ISLAND CITY, N. Y.

Please mention **SHORT WAVE CRAFT** when writing advertisers

KABLE BROS. CO., PRINTERS

NATIONAL NC-100

TWELVE TUBE

SUPERHETERODYNE



STUDY THIS PICTURE!

Here are the essential parts of the Movable-Coil Tuning Unit, removed from the main chassis so that the photograph will show them clearly. Notice the heavy cast aluminum coil shield below the condenser and tubes. Inside this shield are the fifteen high-gain coils, each in its own individual shielded compartment, each insulated with low-loss R-39 insulation, and each padded with air dielectric condensers. The twist of a knob on the front panel slides this cast aluminum shield smoothly along its track, bringing the desired set of coils close to the condenser and tubes, and moving unused coils completely out of the way. A positive detent locks the coils into exact position after each shift. Rugged, silver-plated, side-wipe contacts make dependable low resistance circuit connections.

Notice the precision geared condenser. Backlash is permanently absent from its smooth 20 to 1 ratio, preloaded drive. The Micrometer Dial is direct reading to one part in five hundred, with divisions spread out over an effective scale length of twelve feet. Notice the rigid frame, insulated with moulded Bakelite to prevent noise from circulatory currents. Notice the four point stator insulation of low-loss Isolantite, and the individually insulated rotors.

These are but a few of the features that make the Movable-Coil Tuning Unit so outstanding. Study the illustration carefully. It reveals a layout that takes full advantage of the compactness of metal tubes, a precision that makes logging accurate, and an efficiency that makes performance superlative.

NEW AS TOMORROW!

The Movable-Coil Tuning Unit is the up-to-the-minute answer to an old problem! It is more than a new design, it is a new invention that combines the efficiency of the plug-in coil with the convenience of the coil switch. Efficient because plug-in coils are actually used. Convenient because the twist of a knob on the panel instantly selects any one of five coil ranges from 540 KC to 30 MC. And its precision and its quality match its advanced design, for the NC-100 was designed to be a superlative receiver in every way.

PLUG-IN COIL EFFICIENCY

All of the important advantages of the plug-in coil are found in the Movable-Coil Tuning Unit. Leads are short. Calibration is permanent. Idle coils are moved completely out of the way in thoroughly shielded compartments. There are no dead spots in the NC-100 Receiver.

The Movable-Coil Tuning Unit is not like anything you have ever seen in a receiver before; but only a unique design could make possible such results with knob-controlled range changing. Every part from low-loss R-39 coil forms to air dielectric trimming condensers is designed for high circuit efficiency. Every tube—and there are twelve of them—contributes its full share to the high overall performance.

The circuit of the NC-100 is the outcome of over twenty years experience. One stage

of RF, first detector, and high frequency oscillator, *all with separate tubes*, are used on all ranges. The two IF stages have air dielectric tuning condensers. A bias-type power detector is transformer-coupled to the push-pull output tubes. Ten watts of clear, undistorted output are available. A separate tube provides amplified and delayed AVC action. The CW oscillator has a front-of-panel tuning control for adjusting the pitch of the beat note. A 6E5 tube acts as an indicator both when tuning and when using the RF Gain Control for signal strength measurements.

OPERATING CONVENIENCE

Every care has been lavished upon the NC-100 to make it easy to operate even under the most adverse conditions. Even the phone jack has received its share of attention, for it has been carefully placed so that the phone cord will not get in the operator's way!

But of far more importance to the dyed-in-the-wool fan is the completeness of the controls. Separate Audio and RF Gain Controls, Tone Control, and Crystal Filter Controls for Phasing and Selectivity are all brought out to the front panel, as is also the tuning adjustment for the CW oscillator. Switches are even provided for cutting B-voltage during transmission, and for disconnecting the AVC. But most important of all are the precision coil shifting and the Micrometer Dial, which combine to make tuning a pleasure and logging a science.



NO COUPON NEEDED!

A copy of our free descriptive folder describing the NC-100 Receiver is yours for the asking. Just send us a postcard, saying that you are a Short Wave Craft reader and want a copy of the NC-100 folder. Be sure to write your address plainly!

NATIONAL COMPANY, INC., Malden, Mass., U.S.A.

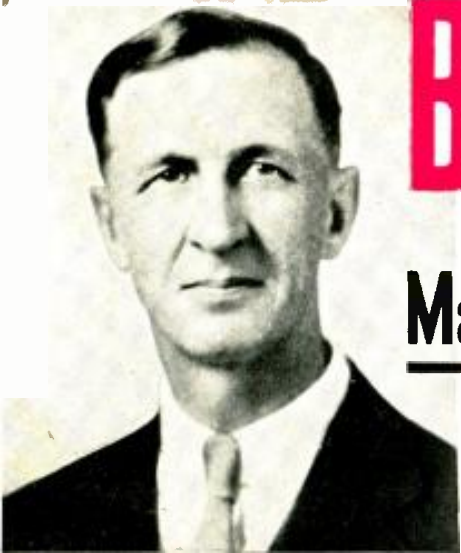

Be a Radio Expert

Many make **\$30 \$50 \$75** a week

I will train you at home for many Good Spare Time and Full Time Radio Jobs

J. E. SMITH, President, National Radio Institute
The man who has directed the home study training of more men for the Radio Industry than any other man in America.



Set Servicing

Spare time set servicing pays many \$5, \$10, \$15 a week extra while learning. Full time servicing pays as much as \$30, \$50, \$75 a week.

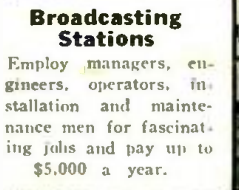

Broadcasting Stations

Employ managers, engineers, operators, installation and maintenance men for fascinating jobs and pay up to \$5,000 a year.



Loud Speaker Systems

Building, installing, servicing and operating public address systems is another growing field for men well trained in Radio.



HERE'S PROOF THAT MY TRAINING PAYS



\$80 Monthly in Spare Time

"I work on Radio part time, still holding my regular job. Since enrolling five years ago, I have averaged around \$80 every month." JOHN B. MORISSETTE, 773 Silver Street, Manchester, N. H.

Makes \$50 to \$60 a Week

"I am making between \$50 and \$60 a week after all expenses are paid, and I am getting all the Radio work I can take care of, thanks to N.R.I." H. W. SPANGLER, 308 Walnut St., Knoxville, Tenn.



Operates Public Address System

"I have a position with the Los Angeles Civil Service operating the Public Address System in the City Hall Council. My salary is \$153 a month." R. H. ROOD, R. 130, City Hall, Los Angeles, Calif.

Lesson on Radio Servicing Tips—FREE

I'll prove that my Training gives practical, money-making information, that it is easy to understand—that it is just what you need to master Radio. My sample lesson text, "Radio Receiver Troubles—Their Cause and Remedy" covers a long list of Radio receiver troubles in A.C., D.C., battery, universal, auto, T. R. F., super-heterodyne, all-wave, and other types of sets. And a cross-reference system gives you the probable cause and a quick way to locate and remedy these set troubles. A special section is devoted to receiver check-up, alignment, balancing, neutralizing and testing. Get this lesson FREE. No obligation. Just mail coupon.



Do you want to make more money? Radio offers you many opportunities for well-paying spare time and full time jobs. And you don't have to give up your present job or leave home and spend a lot of money to become a Radio Expert.

Many Radio Experts Make \$30, \$50, \$75 a Week

Radio broadcasting stations employ engineers, operators, station managers and pay up to \$5,000 a year. Spare time Radio set servicing pays as much as \$200 to \$500 a year—full time jobs with Radio jobbers, manufacturers and dealers as much as \$30, \$50, \$75 a week. Many Radio Experts operate their own full time or part time Radio sales and service businesses. Radio manufacturers and jobbers employ testers, inspectors, foremen, engineers, servicemen, paying up to \$6,000 a year. Radio operators on ships get good pay and see the world besides. Automobile, police, aviation, commercial Radio, and loud speaker systems are newer fields offering good opportunities now and for the future. Television promises to open many good jobs soon. Men I have trained are holding good jobs in these branches of Radio. Read their statements. Mail the coupon.

There's a Real Future in Radio for Well-Trained Men

Radio already gives jobs to more than 300,000 people. In 1935 over \$300,000,000 worth of sets, tubes and parts were sold—an increase of 20% over 1934! Over 1,100,000 auto Radios were sold in 1935, 25% more than in 1934! 22,000,000 homes are today equipped with Radios, and every year millions of these sets go out of date and are replaced with newer models. Millions more need servicing, new tubes, repairs, etc. Broadcasting stations pay their employees (exclusive of artists) more than \$23,000,000 a year! And Radio is a new industry, still growing fast! A few hundred \$30, \$50, \$75-a-week jobs have grown to thousands in less than 20 years!

Many Make \$5, \$10, \$15, a Week Extra in Spare Time While Learning

Practically every neighborhood needs a good spare time serviceman. The day you enroll

I start sending you Extra Money Job Sheets. They show you how to do Radio repair jobs that you can cash in on quickly! Throughout your training I send you plans that made good spare time money—\$200 to \$500 a year—for hundreds of fellows. My Training is famous as "the Course that pays for itself."

I Give You Practical Experience

My Course is not all book training. I send you special Radio equipment and show you how to conduct experiments and build circuits which illustrate important principles used in modern Radio receivers, broadcast stations and loud speaker installations. I show you how to build testing apparatus for use in spare time work from this equipment. This 50-50 method of training makes learning at home interesting, fascinating, practical.

You Get a Money-Back Agreement

I am so sure that I can train you successfully that I agree in writing to refund every penny you pay me if you are not satisfied with my Lessons and Instruction Service when you finish. I'll send you a copy of this agreement with my Free Book.

Find Out What Radio Offers You

Act Today. Mail the coupon now for "Rich Rewards in Radio." It's free to any fellow over 16 years old. It describes Radio's spare time and full time opportunities and those coming in Television; tells about my training in Radio and Television; shows you actual letters from men I have trained, telling what they are doing and earning. Find out what Radio offers YOU! MAIL THE COUPON in an envelope, or paste on a postcard—NOW!

J. E. SMITH, Pres., National Radio Institute
Dept. 6NB3
Washington, D. C.

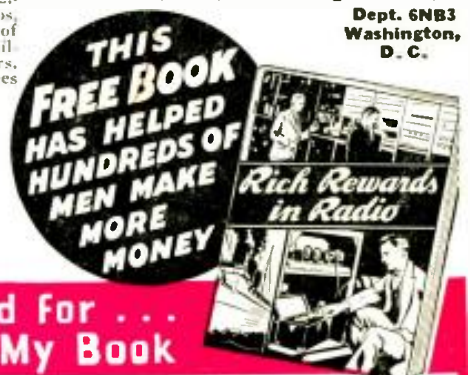

THIS FREE BOOK HAS HELPED HUNDREDS OF MEN MAKE MORE MONEY

This Coupon is Good for . . . One FREE Copy of My Book

J. E. SMITH, President, National Radio Institute, Dept. 6NB3, Washington, D. C.

Without obligating me, send your service manual "Radio Receiver Troubles—Their Cause and Remedy" and free book about spare time and full time Radio opportunities and how I can train for them at home in my spare time. I am particularly interested in the branch of Radio checked below:

- Radio Service Business of My Own
- Spare Time Radio Service Work
- Retail Sales of Radio sets and Equipment
- Service Expert for Retail Stores
- Broadcasting Station Operator
- Aviation Radio Operator
- Ship Radio Operator
- Loud Speaker Systems, Installation and Service
- Auto Radio Installation and Service
- Television Station Operator
- Designing and Constructing Testing Equipment
- Service Expert with Radio Factory
- Commercial Radio Station Operator
- All-around Servicing Expert

(If you have not decided which branch you prefer—mail coupon now, for information to help you decide.)

NAME AGE

ADDRESS FAX-1

If you do not want to cut this cover—simply write us on a post card